

APPLITEC

# APPLITEC

## SWISS TOOLING

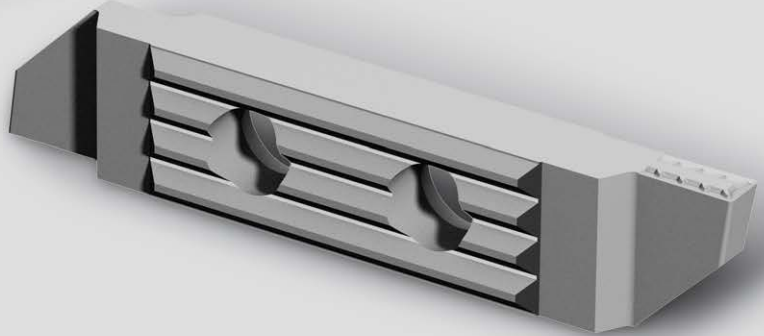
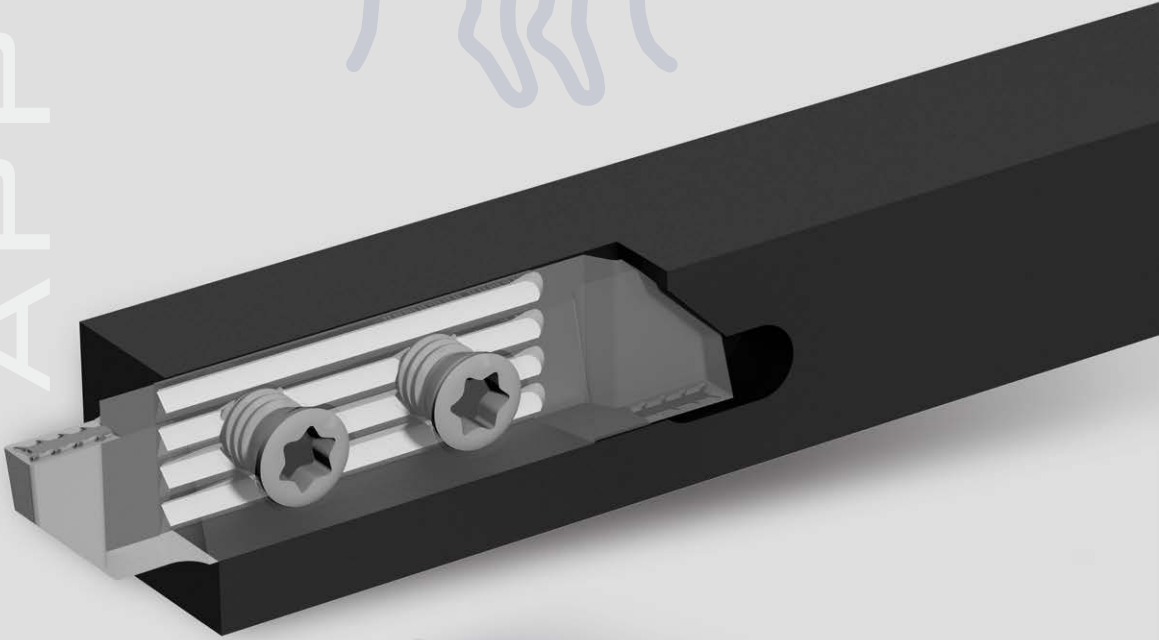

**Applitec S.A.**  
Ch. Nicolas-Junker 2  
CH-2740 Moutier

**2015 - 2017**

Tél. +41 32 494 60 20  
Fax +41 32 493 42 60  
[www.applitec-tools.com](http://www.applitec-tools.com)

APPLITEC

**OUTILS DE HAUTES PERFORMANCES  
POUR LE DÉCOLLETAGE  
ET LA MICROMÉCANIQUE**

**HOCHLEISTUNGSWERKZEUGE  
FÜR DREHAUTOMATEN  
UND MIKROMECHANIK**

**HIGH PERFORMANCE TOOLING  
FOR AUTOMATIC LATHES  
AND MICROMECHANICS**



**[WWW.APPLITEC-TOOLS.COM](http://WWW.APPLITEC-TOOLS.COM)**

	<b>TOP-Line</b>	<b>1</b>
	<b>TOP-Watch</b>	
	<b>TRIO-Line</b>	<b>2</b>
	<b>ECO-Line</b>	<b>3</b>
	<b>ISO-Line</b>	<b>4</b>
	<b>CUT-Line</b>	<b>5</b>
	<b>MODU-Line</b>	<b>6</b>
	<b>TOOLING-Line</b>	<b>7</b>
	<b>MICRO-Line</b>	<b>8</b>
	<b>CIRCO-Line</b>	<b>9</b>
	<b>Index</b>	<b>10</b>

APPLITEC

# IN-Line

D = Ø 4 mm AND Ø 6 mm  
BORING BAR SYSTEM

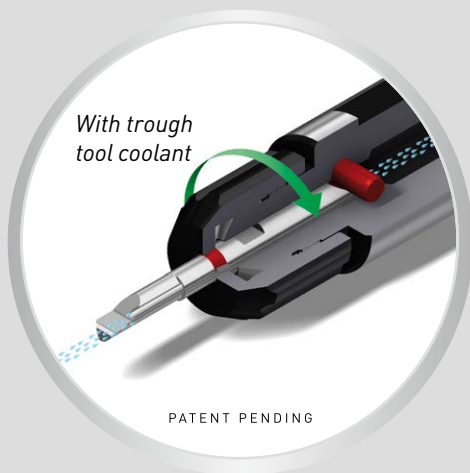

VERY RIGID CLAMPING SYSTEM



APPLITEC  
SWISS TOOLING

# IN-Line

APPLITEC



**Ask for *IN-Line* catalogue!**

[www.applitec-tools.com](http://www.applitec-tools.com)



**INFO**

Nuances et paramètres de coupe  
Sorten und Schnittwerte  
Grades and machining data

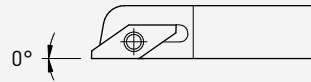
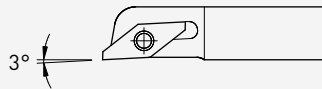
> **1.02****310 / 320**88° > **1.12****330 / 340**85° > **1.16****710 / 720**

pour machines à cames  
für kurvengesteuerte Maschinen  
for cam driven machines

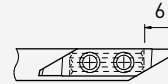
> **1.20****730 / 740**

**main series**  
**small type**

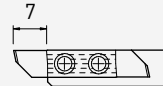
> **1.32****750 / 760**

**main series**  
**large type**

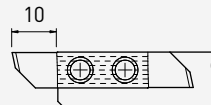
> **1.76**

**770 / 780**  
**7050 / 7060**  
**W750 / W760**

Tronçonnage de grande capacité et ébauches larges pour profilage  
Abstechen für grössere Durchmesser und breite Rohlinge für Profilschleifen  
High capacity parting off and wide blanks for profiling

> **1.129**

**740Z / 760Z**  
**CAPTO**  
**TORNOS**

Porte-outils spéciaux  
Sonderwerkzeughalter  
Special tool holders

> **1.129****TOP-WATCH**

Outils de tournage spécifiques pour l'horlogerie  
Sonderdrehwerkzeuge für Uhrenindustrie  
Special turning tools for watch industry

> **1.160**

Pièces de rechange  
Ersatzteile  
Spare parts

> **1.172**

# TOP-Line

Codification des plaquettes TOP-Line série 700

WSP-Bezeichnungssystem für TOP-Line 700 Serie

Inserts designation key for TOP-Line 700 series

INFO

**7** **6** **4** **X** **-** **2.0** **-** **R20** **-** **HTA**

Dimension  
Abmessung  
Dimension

Rayon  
Radius  
Radius

Nuance  
Sorte  
Grade

Géométrie de coupe / brise-copeaux / particularités  
Schneidgeometrie / Spanbrecher / Sondereigenschaften  
Cutting geometry / chip breaker / special features

Géométrie d'usinage  
Bearbeitungsgeometrie  
Machining geometry

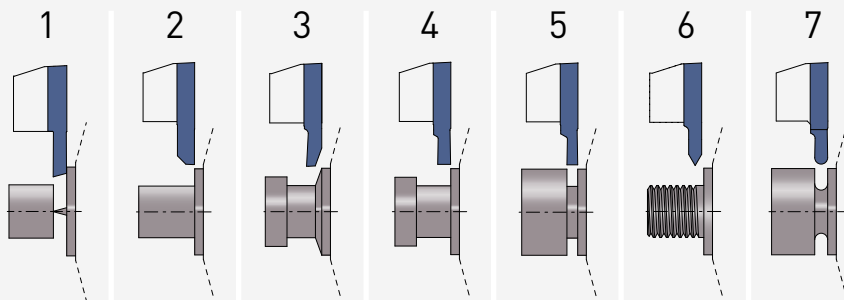

Gamme de produit  
Produktserie  
Product series

définit la compatibilité des plaquettes avec le porte-outil  
bestimmt die WSP und Halter Kompatibilität  
shows the inset and holder compatibility

L = 1, 3, 5, 7 (chiffre impair / ungerade Zahl / uneven number)

R = 2, 4, 6, 8 (chiffre pair / gerade Zahl / even number)

L  
710

R  
720

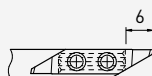

pour machines à cames  
für kurvengesteuerte Maschinen  
for cam driven machines

L  
730

R  
740



main series  
small type

L  
750

R  
760

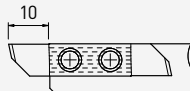

main series  
large type

L  
770

R  
780

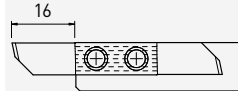

tronçonnage uniquement  
nur für abstechen  
only for parting off

Applitec série 700  
Applitec 700 Serie  
Applitec 700 series

système de serrage à denture décalée avec 2 vis de fixation  
Spannsystem mit 2 Schrauben und verschobener Verzahnung  
shifted teeth clamping system with 2 screws



L'outil de référence pour le décolletage

Hochwertiges Wendeplattensystem für Langdrehautomaten

Top-class turning tools for automatic lathes

## 700 Series

### 100% rigid!

Système de serrage Applitec à denture décalée  
 Applitec-Spannsystem mit verschobener Verzahnung  
 Applitec clamping system with shifted teeth

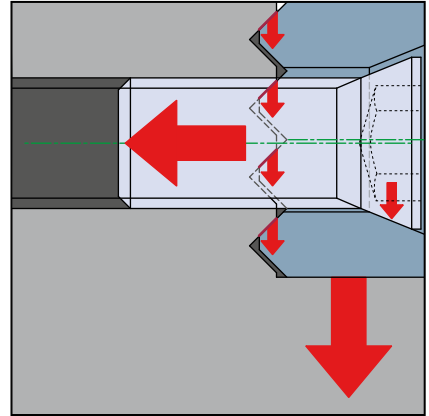
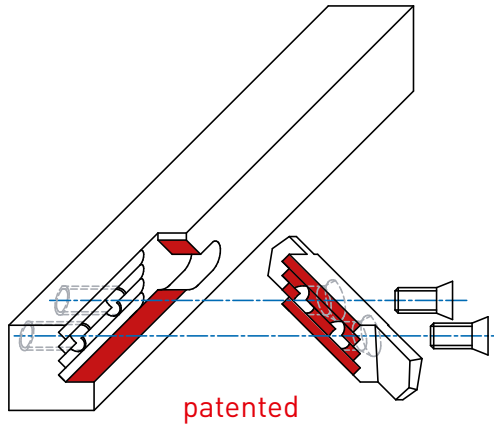

**Serrage standard (A)**  
**Standard Spannsystem (A)**  
**Standard clamping system (A)**

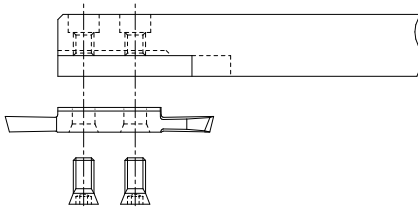

**Serrage type B**  
**Spannsystem Typ B**  
**Clamping system type B**

ajouter -B après le numéro d'article  
 -B nach der Artikelreferenz hinzufügen  
 add -B after the article number

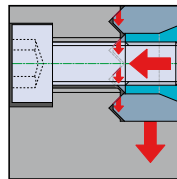
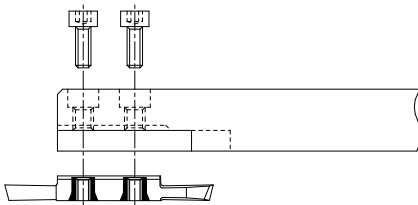

Changement de la plaquette possible dans la machine, sans démontage du porte-outil  
 WSP-Austauschmöglichkeit in der Maschine ohne Halterausbau  
 The insert can be changed in the machine without removing the tool holder

## 700-ZX geometries

Très bonne maîtrise du copeau  
pour matières difficiles

Sehr gute Spankontrolle für  
schwierige Werkstoffe

Very efficient chip control for  
difficult materials

Multitude de géométries possibles

Mehrere mögliche Spangeometrien

Many different cutting geometries are possible

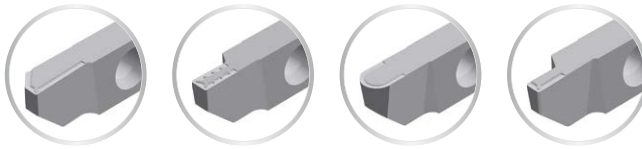

## 300 Series

**3 contact points**

R min = 0

R



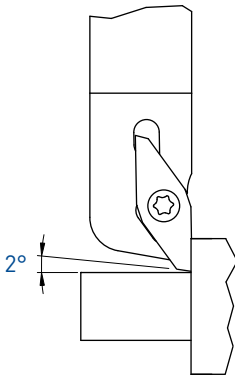



**rigid clamping system**









**“wiper effect”**

Pour un meilleur état de surface  
Für eine bessere Oberflächengüte  
For a better surface finish



Géométries de coupe Spanformgeometrien Cutting geometry		Acier de décolletage Automatenstahl Free-cutting steel	Acier Stahl Steel	Acier inoxydable Rostfreistahl Stainless steel	Aluminium	Titane Titane Titanium	Laiton, bronze Messing, Bronze Brass, bronze	Cuivre Kupfer Copper	1 <sup>er</sup> choix 1. Wahl 1 <sup>st</sup> choice	Recommandé Empfohlen Recommended	Pour pièces fragiles de très petits diamètres Für empfindliche und sehr kleine Werkstücke For fragile and very small work pieces
	3_7	Green	Green	Green	Green	Light Green		Green	Géométrie universelle, très bonne maîtrise du copeau Allgemeine Geometrie, sehr gute Spankontrolle All-round insert with efficient chip control		
	3_7-EN	Light Green	Green	Light Green					Arête renforcée (augmente l'effort de coupe) Verstärkte Schneidkante (Schneidkräfterhöhung) Reinforced cutting edge (increases cutting force) f min: 0.02 mm/U		
	3_8	Orange	Orange	Orange			Green		Géométrie plate classique Standard flache Geometrie Standard flat geometry		
	3_8VS	Light Green		Light Green	Orange	Orange		Orange	Brise-copeau pour usinage léger en finition Spanbrecher für leichte Schlichtbearbeitung Chip-breaker for light finishing operation		
	3_8VX	Green	Green	Green	Green	Green		Green	Très bonne maîtrise du copeau Sehr gute Spankontrolle Very efficient chip control		
	3_8X	Green	Green	Green	Light Green	Green		Light Green	Coupe positive traditionnelle Standard positive Geometrie Standard positive geometry		
	3_9	Light Green	Light Green	Light Green					Témoin plat sur la coupe pour réduire les vibrations Vibrationsreduzierung durch einer Flachfase und der Schneidkante Vibration reduction trough flat ended cutting edge		

Géométries de coupe Spanformgeometrien Cutting geometry	Acier de décolletage Automatenstahl Free-cutting steel	Acier Stahl Steel	Acier inoxydable Rostfreistahl Stainless steel	Aluminium	Titane Titane Titanium	Laiton, bronze Messing, Bronze Brass, bronze	Cuivre Kupfer Copper	1 <sup>er</sup> choix 1. Wahl 1 <sup>st</sup> choice
								Recommandé Empfohlen Recommended
								Pour pièces fragiles de très petits diamètres Für empfindliche und sehr kleine Werkstücke For fragile and very small work pieces
 0°								Permet un réaffûtage aisé Erlaubt einfaches Nachschleifen Allows easy regrinding
 X4°								Réduit l'effort de coupe, réaffûtable Reduziert Schneidkräfte, nachschleifbar Decreases cutting force, allows regrinding
 XF								Pour matières difficiles (pointe renforcée) Für schwierige Werkstoffe (verstärkte Spitze) For difficult materials (reinforced point)
 X12°								Très bonne maîtrise du copeau Sehr gute Spankontrolle Very efficient chip control
 X25°								Pour matières collantes faisant de très longs copeaux Für klebrige Werkstoffe mit sehr langen Spänen For long chipping sticky materials
 U								Pour resserrer le copeau, réaffûtage aisé Für Spanversmälnerung, einfaches Nachschleifen To narrow the chips, easy regrinding

Conseils d'utilisation

Anwendungsempfehlungen









Application recommendations

Tournage

Drehen

Turning

## 700 Series

Géométries de coupe Spanformgeometrien Cutting geometry		Acier de décolletage Automatenstahl Free-cutting steel	Acier Stahl Steel	Acier inoxydable Rostfreistahl Stainless steel	Aluminium	Titane Titane Titanium	Laiton, bronze Messing, Bronze Brass, bronze	Cuivre Kupfer Copper	1 <sup>er</sup> choix 1. Wahl 1 <sup>st</sup> choice	Recommandé Empfohlen Recommended	Pour pièces fragiles de très petits diamètres Für empfindliche und sehr kleine Werkstücke For fragile and very small work pieces
	0°	Green	Orange	Orange	Orange	Orange	Green	Orange	Green	Green	Permet un réaffûtage aisé Erlaubt einfaches Nachschleifen Allows easy regrinding
	X	Green	Green	Green	Green	Green	Grey	Green	Green	Green	Coupe positive traditionnelle Standard positive Geometrie Standard positive geometry
	VX8°	Green	Green	Light Green	Light Green	Light Green	Grey	Light Green	Light Green	Light Green	Très bonne maîtrise du copeau Sehr gute Spankontrolle Very efficient chip control
	VX15°	Light Green	Grey	Light Green	Green	Green	Grey	Green	Light Green	Light Green	Très bonne maîtrise du copeau Sehr gute Spankontrolle Very efficient chip control
	VS	Light Green	Grey	Light Green	Orange	Orange	Grey	Orange	Light Green	Light Green	Brise-copeau pour usinage léger en finition Spanbrecher für leichte Schlichtbearbeitung Chip-breaker for light finishing operation
	ZX10	Green	Green	Green	>5% Si	Light Green	Light Green	Grey	Green	Green	Très bonne maîtrise du copeau Sehr gute Spankontrolle Very efficient chip control f min: 0.02 mm/U
	ZX17	Green	Green	Light Green	>5% Si	Green	Grey	Green	Green	Green	Très bonne maîtrise du copeau Sehr gute Spankontrolle Very efficient chip control f min: 0.02 mm/U
	ZX25	Green	Green	Light Green	>5% Si	Green	Grey	Green	Green	Green	Très bonne maîtrise du copeau Sehr gute Spankontrolle Very efficient chip control f min: 0.02 mm/U
	ZXT	Green	Green	Green	>5% Si	Light Green	Light Green	Grey	Green	Green	Très bonne maîtrise du copeau Sehr gute Spankontrolle Very efficient chip control f min: 0.02 mm/U

<b>TiALN</b> μK20 + revêtement PVD μK20 + PVD Beschichtung μK20 + PVD coating	<b>TiN</b> μK20 + revêtement PVD μK20 + PVD Beschichtung μK20 + PVD coating	<b>N (μK20)</b> non revêtu unbeschichtet uncoated
<ul style="list-style-type: none"><li>• excellente nuance universelle</li><li>• 1<sup>er</sup> choix pour l'usinage des aciers, aciers inoxydables et alliages de titane</li><li>• très bonne résistance à la température</li></ul>	<ul style="list-style-type: none"><li>• nuance pour l'usinage des matières peu résistantes qui créent des arêtes rapportées</li><li>• très faible coefficient de frottement</li><li>• à éviter pour l'usinage du titane</li></ul>	<ul style="list-style-type: none"><li>• supporte les coupes interrompues et autres conditions d'usinage défavorables</li></ul>
<ul style="list-style-type: none"><li>• beste Universalsorte</li><li>• für die Bearbeitung von Stahl, rostfreiem Stahl und Titanlegierungen bestens geeignet</li><li>• sehr gute Warmfestigkeit</li></ul>	<ul style="list-style-type: none"><li>• Sorte für die Bearbeitung von weichen Werkstoffen mit Tendenz zur Bildung von Aufbauschneiden</li><li>• sehr geringer Reibwert</li><li>• für die Bearbeitung von Titan nicht geeignet</li></ul>	<ul style="list-style-type: none"><li>• für unterbrochene Schnitte und andere ungünstige Bearbeitungsbedingungen geeignet</li></ul>
<ul style="list-style-type: none"><li>• best universal grade</li><li>• first choice for steel, stainless steel and titanium alloys machining</li><li>• very good heat resistance</li></ul>	<ul style="list-style-type: none"><li>• grade for the machining of low resistance materials which causes edge build-up</li><li>• very low friction ratio</li><li>• not suitable for titanium machining</li></ul>	<ul style="list-style-type: none"><li>• suitable for interrupted cut and other unfavourable machining conditions</li></ul>

## Nuances micro-grain à dureté élevée

### Verschleissfeste Feinkornsorten

### Wear resistant micro-grain grades

#### HTA

μK10 + revêtement PVD  
μK10 + PVD Beschichtung  
μK10 + PVD coating

- nuance très résistante à l'usure
- pour l'usinage en finition dans des conditions favorables des aciers, aciers inoxydables et alliages de titane

- sehr verschleissfeste Sorte
- für die Feinbearbeitung von Stahl, rostfreiem Stahl und Titanlegierungen bei guten Bearbeitungsbedingungen

- very wear resistant grade
- for light machining of steel, stainless steel and titanium alloys under favourable machining conditions

#### HAS

μK10 + revêtement PVD  
μK10 + PVD Beschichtung  
μK10 + PVD coating

- nuance pour métaux non ferreux
- très faible coefficient de frottement
- 1<sup>er</sup> choix pour l'usinage des aluminiums jusqu'à 5% Si, des cuivres et titanes faiblement alliés

- Sorte für Nichteisenmetalle
- sehr geringer Reibwert
- für die Bearbeitung von Aluminium bis 5% Si, Kupfer und niedriglegiertem Titan bestens geeignet

- grade for non-ferrous materials
- very low friction ratio
- first choice for aluminium up to 5% Si, copper and low alloyed titanium

#### HTiN

μK10 + revêtement PVD  
μK10 + PVD Beschichtung  
μK10 + PVD coating

- nuance pour l'usinage en finition des matières peu résistantes qui créent des arêtes rapportées
- très faible coefficient de frottement
- à éviter pour l'usinage du titane

- Sorte für die Feinbearbeitung von weichen Werkstoffen mit Tendenz zur Bildung von Aufbauschneiden
- sehr geringer Reibwert
- für die Bearbeitung von Titan nicht geeignet

- grade for light machining of low resistance materials which causes edge build-up
- very low friction ratio
- not suitable for titanium machining

#### HN (μK10)

non revêtu  
unbeschichtet  
uncoated

- nuance micro-grain très résistante à l'usure
- recommandé pour l'usinage du titane faiblement allié
- déconseillé en cas de coupe interrompue et autres conditions d'usinage défavorables

- verschleissfeste Feinkornsorte
- empfehlenswert für die Bearbeitung von niedrig legiertem Titan
- für unterbrochene Schnitte und andere ungünstige Bearbeitungsbedingungen nicht geeignet

- wear resistant micro-grain grade
- suitable for the machining of low alloyed titanium
- not suitable for interrupted cut and other unfavourable machining conditions

## Paramètres de coupe indicatifs

## Empfohlene Schnittwerte

## Standard machining data

Matière Werkstoff Material	Tournage Drehen Turning			Tronçonnage Abstechen Parting off		
	VC	Prof. de passe Schnitttiefe Depth of cut	Avance Vorschub Feed	VC	Largeur de coupe Abstechbreite Cutting width	Avance Vorschub Feed
	(m/min)	(mm)	(mm/U)	(m/min)	(mm)	(mm/U)
Acier de décolletage Automatenstahl Free-cutting steel	120 - 200	0.05 - 1.0 1.0 - 4.0	0.01 - 0.15 0.05 - 0.25	80 - 150	0.50 - 1.50 1.50 - 3.50	0.01 - 0.08 0.03 - 0.15
Acier Stahl < 600 N/mm <sup>2</sup> Steel	80 - 160	0.05 - 1.0 1.0 - 4.0	0.01 - 0.15 0.05 - 0.25	70 - 120	0.50 - 1.50 1.50 - 3.50	0.01 - 0.06 0.03 - 0.12
Acier Stahl < 800 N/mm <sup>2</sup> Steel	60 - 120	0.05 - 1.0 1.0 - 4.0	0.01 - 0.10 0.05 - 0.20	60 - 100	0.50 - 1.50 1.50 - 3.50	0.01 - 0.05 0.03 - 0.10
Acier Stahl > 800 N/mm <sup>2</sup> Steel	50 - 100	0.05 - 1.0 1.0 - 3.0	0.01 - 0.08 0.05 - 0.15	40 - 80	0.50 - 1.50 1.50 - 3.50	0.01 - 0.04 0.03 - 0.08
Acier inoxydable Rostfreistahl Stainless steel	60 - 120	0.05 - 1.0 1.0 - 3.0	0.01 - 0.08 0.05 - 0.15	60 - 100	0.50 - 1.50 1.50 - 3.50	0.01 - 0.04 0.03 - 0.08
Aluminium Si <12%	200 - 1000	0.05 - 1.0 1.0 - 4.0	0.01 - 0.20 0.05 - 0.40	180 - 400	0.50 - 1.50 1.50 - 3.50	0.01 - 0.10 0.03 - 0.20
Aluminium Si >12%	180 - 800	0.05 - 1.0 1.0 - 4.0	0.01 - 0.20 0.05 - 0.40	150 - 300	0.50 - 1.50 1.50 - 3.50	0.01 - 0.10 0.03 - 0.20
Titane Titan Titanium	30 - 70	0.05 - 1.0 1.0 - 4.0	0.01 - 0.08 0.05 - 0.15	30 - 50	0.50 - 1.50 1.50 - 3.50	0.01 - 0.03 0.03 - 0.06
Cuivre, laiton, bronze Kupfer, Messing, Bronze Copper, brass, bronze	100 - 500	0.05 - 1.0 1.0 - 4.0	0.01 - 0.20 0.05 - 0.35	100 - 300	0.50 - 1.50 1.50 - 3.50	0.01 - 0.10 0.03 - 0.20



## Indications pour premier réglage

## Hinweise für die erste Einrichtung

## Indications for first setting

<b>Ebauche</b> <b>Schruppen</b> <b>Roughing</b>	<b>Finition</b> <b>Schlichten</b> <b>Finishing</b>
<ul style="list-style-type: none"> <li>• Vitesse de coupe moyenne</li> <li>• Avance élevée</li> </ul>	<ul style="list-style-type: none"> <li>• Vitesse de coupe élevée</li> <li>• Avance faible</li> </ul>
<ul style="list-style-type: none"> <li>• Durchschnittliche Schnittgeschwindigkeit</li> <li>• Hohe Schnittgeschwindigkeit</li> </ul>	<ul style="list-style-type: none"> <li>• Hohe Schnittgeschwindigkeit</li> <li>• Niedriger Vorschub</li> </ul>
<ul style="list-style-type: none"> <li>• Average cutting speed</li> <li>• High cutting speed</li> </ul>	<ul style="list-style-type: none"> <li>• High cutting speed</li> <li>• Low cutting feed</li> </ul>

### Remarques importantes Wichtige Bemerkungen Important remarks

- En raison des limites de la machine, il n'est souvent pas possible d'atteindre les vitesses de coupe préconisées.
- Les outils Applitec sont spécialement développés pour permettre de hautes performances, même dans des conditions de coupe défavorables.
- Des applications non préconisées dans le tableau ci-contre peuvent également s'avérer efficaces.

- Wegen begrenzter Maschinenleistung ist es oft nicht möglich, die vorgeschlagenen Schnittgeschwindigkeiten zu erreichen.
- Applitec Werkzeuge sind besonders dazu entwickelt, um sogar bei ungünstigen Schnittdaten leistungsfähig zu sein.
- Die in der nebenstehender Tabelle nicht erwähnten Anwendungsfälle können sich auch effizient erweisen.

- In many cases, it is impossible to reach the recommended cutting speed, due to the machine limits.
- Applitec tools are especially designed to be efficient even in bad cutting conditions.
- Applications not mentioned in the opposite table can also be efficient.

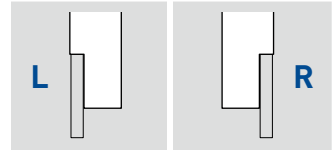
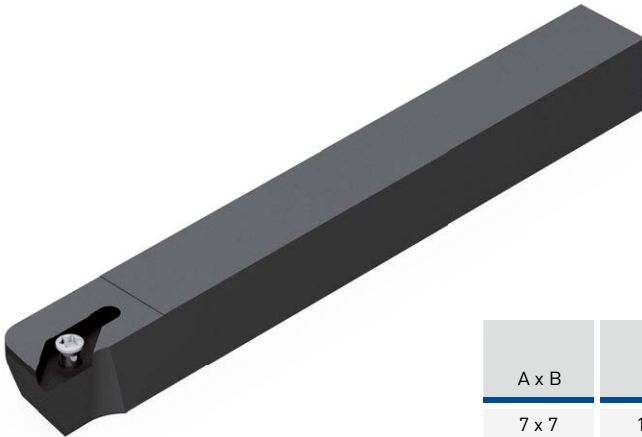
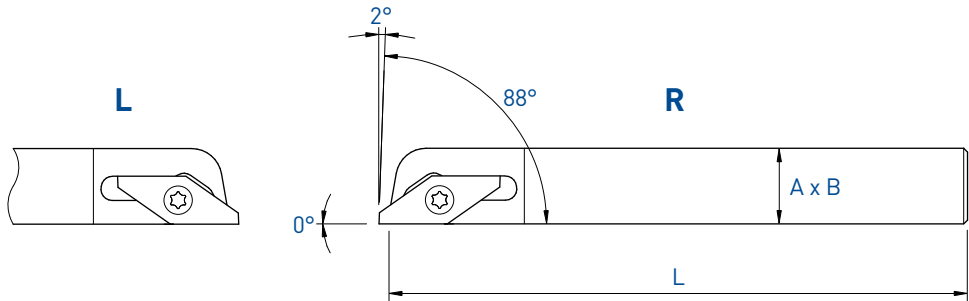

A x B	L	Art. N°	Art. N°
7 x 7	115	311	321
8 x 8	115	312	322
10 x 10	115	313	323
10 x 10	140	-	323-140
12 x 12	115	314	324
12 x 12	90	314-90	324-90
12 x 12	140	314-140	324-140
12.7 x 12.7	140	314-12.7	324-12.7
16 x 16	100	315	325
16 x 16	140	315-140	325-140
20 x 20	120	316	326

Chaque support est livré avec vis et clé.  
 Jeder Halter wird mit Spannschraube(n) und Schlüssel geliefert.  
 Screw(s) and key are included with each tool holder.

Porte-outils

Halter

Holder

88°

310-BC / 320-BC

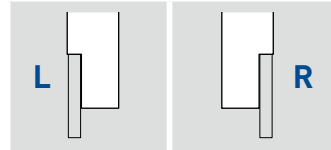
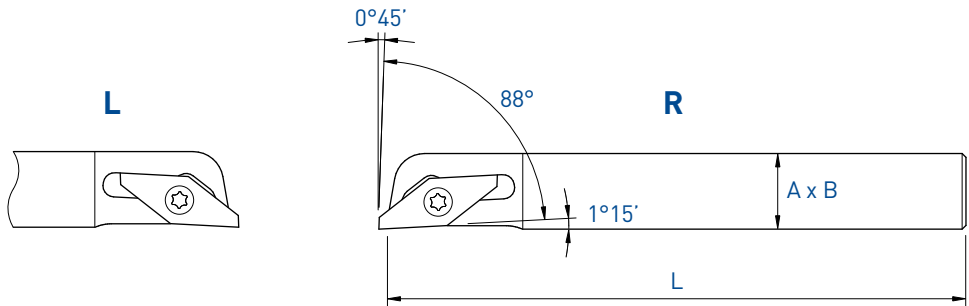

A x B	L	Art. N°	Art. N°
7 x 7	115	<b>311-BC</b>	<b>321-BC</b>
8 x 8	115	<b>312-BC</b>	<b>322-BC</b>
10 x 10	115	<b>313-BC</b>	<b>323-BC</b>
10 x 10	140	-	<b>323-140-BC</b>
12 x 12	115	<b>314-BC</b>	<b>324-BC</b>
12 x 12	90	<b>314-90-BC</b>	<b>324-90-BC</b>
12 x 12	140	<b>314-140-BC</b>	<b>324-140-BC</b>
12.7 x 12.7	140	<b>314-12.7-BC</b>	<b>324-12.7-BC</b>
16 x 16	100	<b>315-BC</b>	<b>325-BC</b>
16 x 16	140	<b>315-140-BC</b>	<b>325-140-BC</b>
20 x 20	120	<b>316-BC</b>	<b>326-BC</b>

Chaque support est livré avec vis et clé.

Jeder Halter wird mit Spannschraube(n) und Schlüssel geliefert.

Screw(s) and key are included with each tool holder.

# TOP-Line

Tourneur avant  
Vorwärts drehen  
Front turning

88°

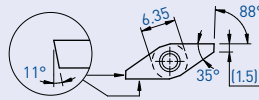

310 / 320

317 / 327



L

R

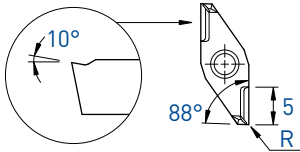

R	Art. N°	TiAlN	TiN	N (µk20)	HTA	HTiN	HN (µk10)	Art. N°	TiAlN	TiN	N (µk20)	HTA	HTiN	HN (µk10)
0	317	■	■	■	■	■	■	327	■	■	■	■	■	■
0.03	317-R03	■	■	■	■	■	■	327-R03	■	■	■	■	■	■
0.08	317-R08	■	■	■	■	■	■	327-R08	■	■	■	■	■	■
0.1	317-R10	■	■	■	■	■	■	327-R10	■	■	■	■	■	■
0.2	317-R20	■	■	■	■	■	■	327-R20	■	■	■	■	■	■

318 / 328



L

R

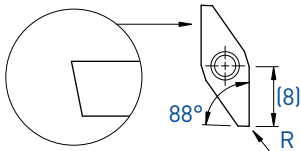

R	Art. N°	HTA	HTiN	HN (µk10)	Art. N°	HTA	HTiN	HN (µk10)
0	318	■	■	■	328	■	■	■
0.05	318-R05	■	■	■	328-R05	■	■	■
0.1	318-R10	■	■	■	328-R10	■	■	■
0.2	318-R20	■	■	■	328-R20	■	■	■
0.4	318-R40	■	■	■	328-R40	■	■	■

318VS / 328VS



L

R

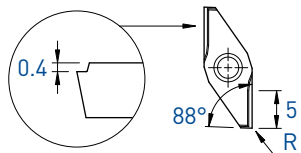

R	Art. N°	HTA	HTiN	HN (µk10)	Art. N°	HTA	HTiN	HN (µk10)
0	318VS	■	■	■	328VS	■	■	■
0.1	318VS-R10	■	■	■	328VS-R10	■	■	■

Tourneur avant  
Vorwärts drehen  
Front turning

88°

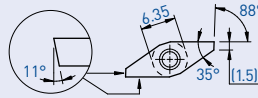

310 / 320

## 318VX / 328VX



L

R

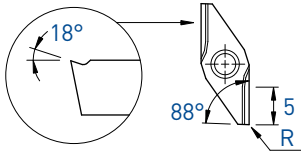

R	Art. N°	HTA	HTIN	HN (µkt10)	Art. N°	HTA	HTIN	HN (µkt10)
0	318VX	■	■	■	328VX	■	■	■
0.05	318VX-R05	■	■	■	328VX-R05	■	■	■
0.1	318VX-R10	■	■	■	328VX-R10	■	■	■
0.2	-				328VX-R20	■	■	■

## 318X / 328X



L

R

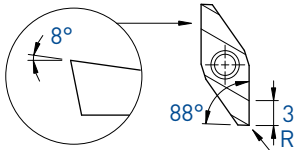

R	Art. N°	HTA	HTIN	HN (µkt10)	Art. N°	HTA	HTIN	HN (µkt10)
0	318X	■	■	■	328X	■	■	■
0.1	318X-R10	■	■	■	328X-R10	■	■	■

## 319 / 329



L

R

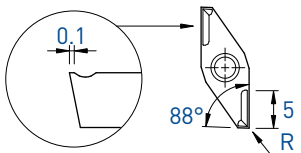

R	Art. N°	HTA	HTIN	HN (µkt10)	Art. N°	HTA	HTIN	HN (µkt10)
0	319	■	■	■	329	■	■	■
0.1	319-R10	■	■	■	329-R10	■	■	■
0.2	319-R20	■	■	■	329-R20	■	■	■

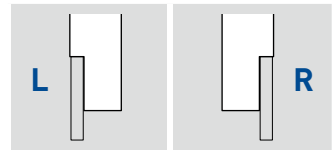
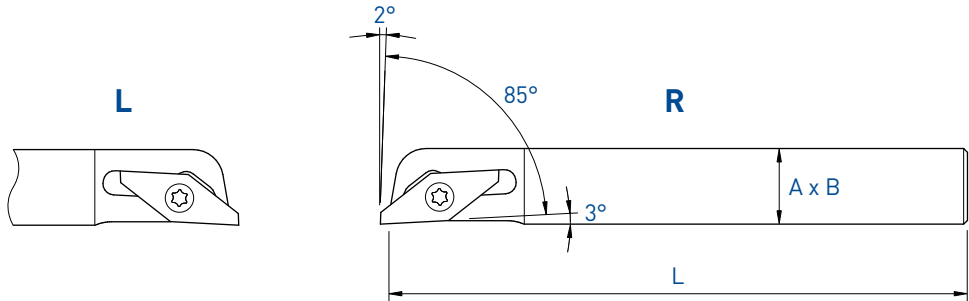

A x B	L	Art. N°	Art. N°
8 x 8	115	332	342
10 x 10	115	333	343
10 x 10	140	-	343-140
12 x 12	115	334	344
12 x 12	90	334-90	344-90
12 x 12	140	334-140	344-140
12.7 x 12.7	140	334-12.7	344-12.7
16 x 16	100	335	345
16 x 16	140	335-140	345-140
20 x 20	120	336	346

Porte-outils avec arrosage intégré

Halter mit integriertem Kühlmittelzufuhr

Holder with integrated coolant supply

85°

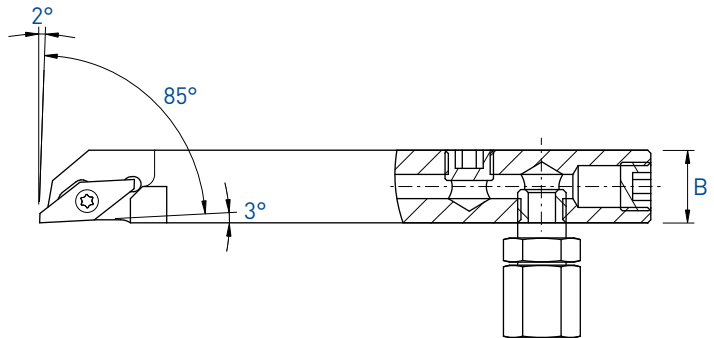
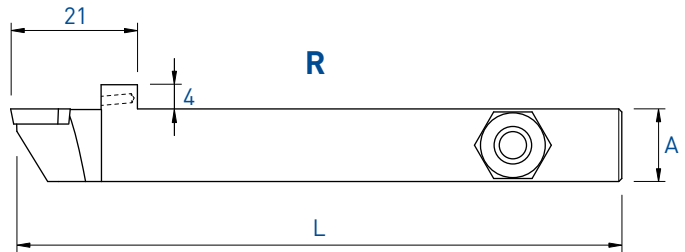

340-JET

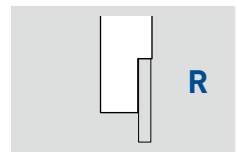
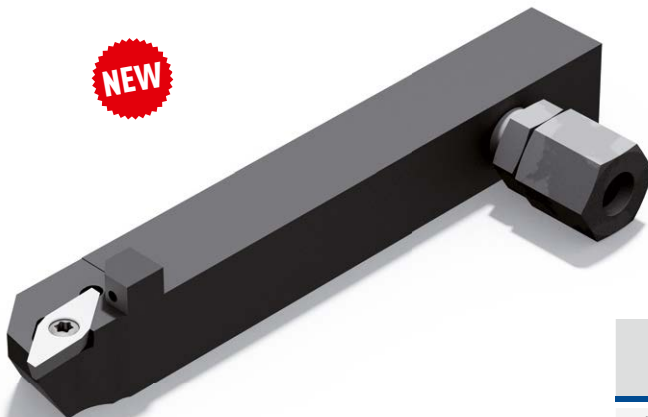

**NEW**



A x B	L	Art. N°
10 x 12	100	<b>340-1012-JET</b>
12 x 12	100	<b>340-12-JET</b>
12.7 x 12.7	100	<b>340-12.7-JET</b>
16 x 16	100	<b>340-16-JET</b>
20 x 20	100	<b>340-20-JET</b>

Pièces de rechange Ersatzteile Spare parts		
	Art. N°	Art. N°
340-JET	<b>J-M8X1-D6</b>	<b>JB-M8X1</b>

Chaque support est livré avec vis et clé.

Jeder Halter wird mit Spannschraube(n) und Schlüssel geliefert.  
Screw(s) and key are included with each tool holder.

Tourneur avant  
Vorwärts drehen  
Front turning

85°

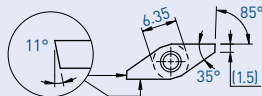

330 / 340

337 / 347



L

R

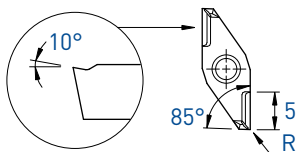

R	Art. N°	TiALN	TiN	N (µk10)	HTA	HTIN	HN (µk10)	Art. N°	TiALN	TiN	N (µk10)	HTA	HTIN	HN (µk10)
0	337	■	■	■	■	■	■	347	■	■	■	■	■	■
0.03	337-R03	■	■	■	■	■	■	347-R03	■	■	■	■	■	■
0.08	337-R08	■	■	■	■	■	■	347-R08	■	■	■	■	■	■
0.1	337-R10	■	■	■	■	■	■	347-R10	■	■	■	■	■	■
0.2	337-R20	■	■	■	■	■	■	347-R20	■	■	■	■	■	■
0	337-EN	■	■	■				347-EN	■	■	■	■	□	■
0.03	337-EN-R03	■	□	■	■	□	■	347-EN-R03	■	□	■	■	□	■
0.08	337-EN-R08	■	□	■				347-EN-R08	■	■	■	■	□	■
0.1	337-EN-R10	■	□	■				347-EN-R10	■	■	■	■	□	■
0.2	337-EN-R20	■	□	■				347-EN-R20	■	■	■	■	□	■

338 / 348



L

R

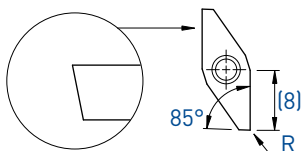

R	Art. N°	HTA	HTIN	HN (µk10)	Art. N°	HTA	HTIN	HN (µk10)
0	338	■	■	■	348	■	■	■
0.05	338-R05	■	■	■	348-R05	■	■	■
0.1	338-R10	■	■	■	348-R10	■	■	■
0.2	338-R20	■	■	■	348-R20	■	■	■
0.4	338-R40	■	■	■	348-R40	■	■	■

338VS / 348VS



L

R

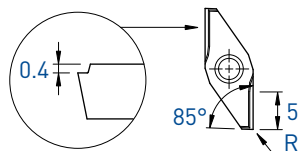

R	Art. N°	HTA	HTIN	HN (µk10)	Art. N°	HTA	HTIN	HN (µk10)
0	338VS	■	■	■	348VS	■	■	■
0.1	338VS-R10	■	■	■	348VS-R10	■	■	■



Tourneur avant  
Vorwärts drehen  
Front turning

85°

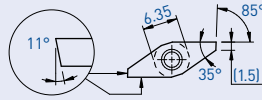

330 / 340

## 338VX / 348VX



L

R

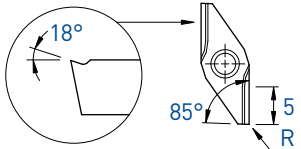

R	Art. N°	HTA	HTiN	HN (µk10)	Art. N°	HTA	HTiN	HN (µk10)
0	338VX	■	■	■	348VX	■	■	■
0.05	338VX-R05	■	■	■	348VX-R05	■	■	■
0.1	338VX-R10	■	■	■	348VX-R10	■	■	■

## 338X / 348X



L

R

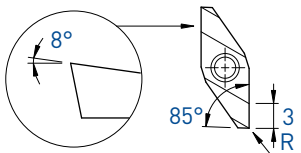

R	Art. N°	HTA	HTiN	HN (µk10)	Art. N°	HTA	HTiN	HN (µk10)
0	338X	■	■	■	348X	■	■	■
0.1	338X-R10	■	■	■	348X-R10	■	■	■

## 339 / 349



L

R

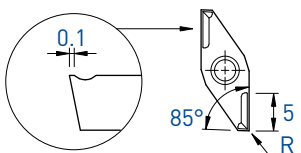

R	Art. N°	HTA	HTiN	HN (µk10)	Art. N°	HTA	HTiN	HN (µk10)
0	339	■	■	■	349	■	■	■
0.1	339-R10	■	■	■	349-R10	■	■	■
0.2	339-R20	■	■	■	349-R20	■	■	■

L		R	
Type	Page	Type	Page
710	1.22	720	1.22
710-NOVIBRA	1.23	721	1.24
711	1.24	721-EP	1.31
711-EP	1.31	722	1.25
712	1.25	723-30	1.26
713-30	1.26	723-45	1.27
713-45	1.27	723-60	1.28
713-60	1.28	724	1.29
714	1.29	726-60	1.30
716-60	1.30		

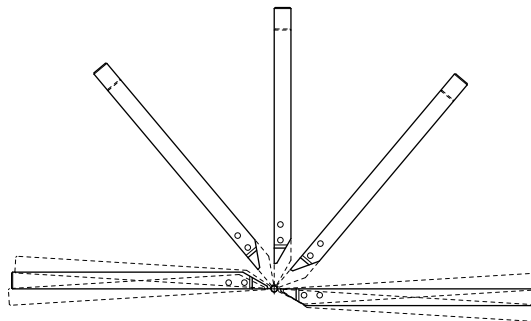

Porte-outils et plaquettes pour machines à cames  
 Halter und WSP Laisser für kurvengesteuerte Maschinen  
 Tool holders and inserts for cam driven machines

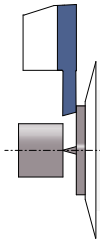
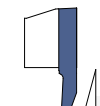
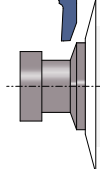
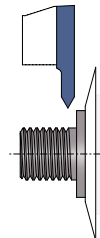
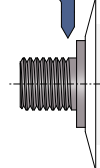
		<b>710 / 720</b> Porte-outils Halter Holders	> 1.22
	<b>711 / 721</b> Tronçonnage Abstechen Parting off		> 1.24
		<b>712 / 722</b> Tourneur avant Vorwärts drehen Front turning	> 1.25
	<b>713 / 723</b> Tourneur arrière Rückwärts drehen Back turning		> 1.26
		<b>714 / 724</b> Foncer-tourner Einstechen und drehen Grooving and turning	> 1.29
	<b>716 / 726</b> Fileter Gewinde drehen Threading		> 1.30
		Plaquette ébauche WSP-Rohling Blank insert	> 1.31

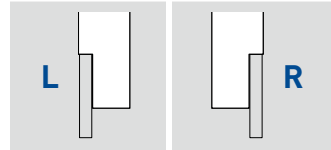
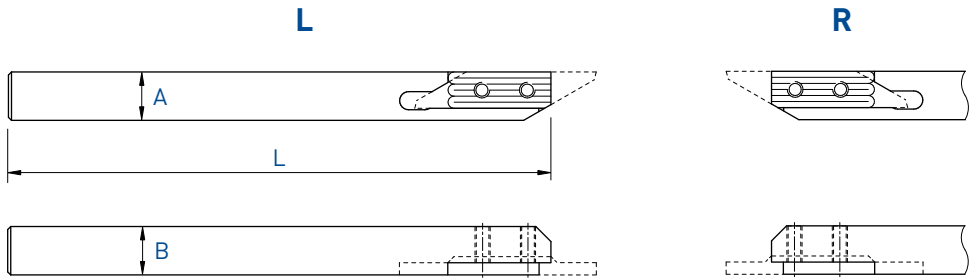

A x B	L	Serrage Spannsystem Clamping	Art. N°	Art. N°
6 x 6	115	A	<b>710-6</b>	-
7 x 7	115	A	<b>710-7</b>	<b>720-7</b>
8 x 8	115	A	<b>710-8</b>	<b>720-8</b>
8 x 8	140	A	<b>710-8-140</b>	-
10 x 10	115	A	<b>710-10</b>	<b>720-10</b>
12 x 12	130	A	<b>710-12</b>	<b>720-12</b>

Chaque support est livré avec vis et clé.  
 Jeder Halter wird mit Spannschraube(n) und Schlüssel geliefert.  
 Screw(s) and key are included with each tool holder.

Porte-outils

Halter

Holder

## 710-NOVIBRA

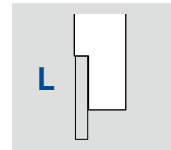
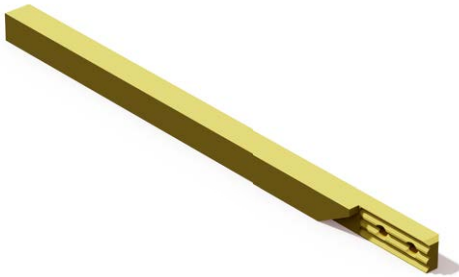
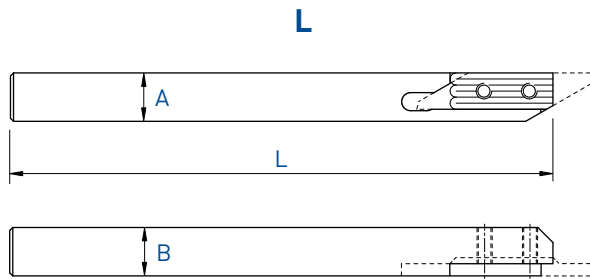

A x B	L	Serrage Spannsystem Clamping	Art. N°
6 x 6	115	A	<b>710-6-NOVIBRA</b>
7 x 7	115	A	<b>710-7-NOVIBRA</b>
8 x 8	115	A	<b>710-8-NOVIBRA</b>

Chaque support est livré avec vis et clé.  
 Jeder Halter wird mit Spannschraub(e)n und Schlüssel geliefert.  
 Screw(s) and key are included with each tool holder.

L

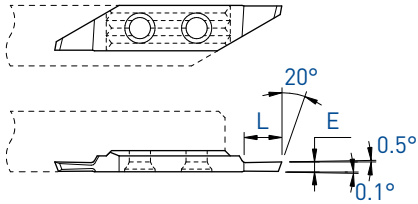

R

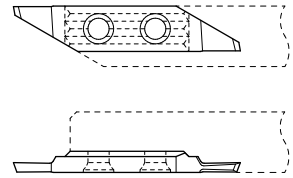

L



R



E	L	Art. N°	TiALN	TiN	N (µk20)	HTA	HTiN	HN (µk10)	Art. N°	TiALN	TiN	N (µk20)	HTA	HTiN	HN (µk10)
0.5	2	711-0.5	■	■	■	■	□	■	-						
0.8	3	711-0.8	■	■	■	■	■	■	721-0.8	■	■	■			
0.9	3	711-0.9	■	■	■	■	□	■	-						
1.0	4	711-1.0	■	■	■	■	■	■	721-1.0	■	■	■	■	□	■
1.1	4	711-1.1	■	■	■	■	■	■	-						
1.2	5	711-1.2	■	■	■	■	■	■	721-1.2	■	■	■	■	□	■
1.3	5	711-1.3	■	■	■	■	□	■	-						
1.4	5	711-1.4	■	■	■				-						
1.5	6.5	711-1.5	■	■	■	■	■	■	721-1.5	■	■	■	■	□	■
1.8	6.5	711-1.8	■	■	■	■	□	■	721-1.8	■	■	■			
2.0	6.5	711-2.0	■	■	■				721-2.0	■	■	■			

Tourneur avant  
Vorwärts drehen  
Front turning

712 / 722

L

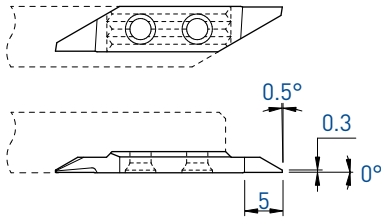

R

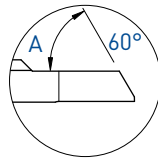
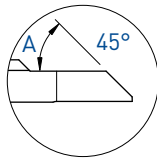
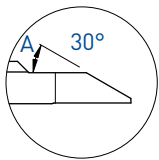
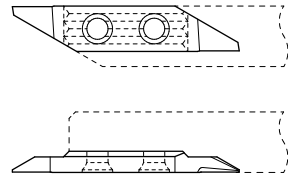

	L						R							
A	Art. N°	TiAlN	TiN	N (µk20)	HTA	HTIN	HN (µk10)	Art. N°	TiAlN	TiN	N (µk20)	HTA	HTIN	HN (µk10)
30°	712-30	■	■	■	■	□	■	722-30	■	■	■	■	□	■
45°	712-45	■	■	■	■	■	■	722-45	■	■	■	■	□	■
60°	712-60	■	■	■	■	□	■	722-60	■	■	■	■	□	■

# TOP-Line

Tourneur arrière  
Rückwärts drehen  
Back turning

713-30° / 723-30°

L

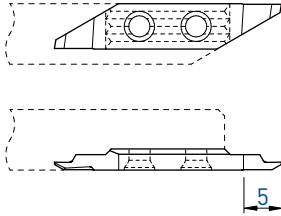

R

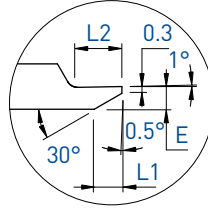
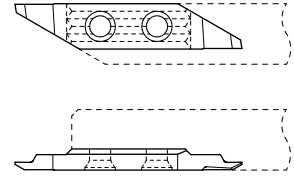

L



R



E	- L1	L2	Art. N°	TiALN	TiN	N (µk20)	HTA	HTiN	HN (µk10)	Art. N°	TiALN	TiN	N (µk20)	HTA	HTiN	HN (µk10)
0.8	0.85	1.6	713-30-0.8	■	■	■				723-30-0.8	■	■	■	■	□	■
0.9	1.05	1.6	713-30-0.9	■	■	■				-						
1.0	1.2	2.0	713-30-1.0	■	■	■	■	□	■	723-30-1.0	■	■	■	■	□	■
1.1	1.4	2.0	713-30-1.1	■	■	■				-						
1.2	1.55	2.5	713-30-1.2	■	■	■				723-30-1.2	■	■	■			
1.3	1.7	2.5	713-30-1.3	■	■	■				-						
1.4	1.9	3.0	713-30-1.4	■	■	■				-						
1.5	2.1	3.0	713-30-1.5	■	■	■	■	■	■	723-30-1.5	■	■	■	■		
1.8	2.6	4.0	713-30-1.8	■	■	■				723-30-1.8	■	■	■			
2.0	3.0	4.0	713-30-2.0	■	■	■	■	■	■	723-30-2.0	■	■	■			



Tourneur arrière  
Rückwärts drehen  
Back turning

713-45° / 723-45°

L

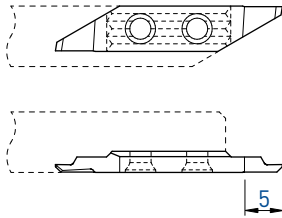

R

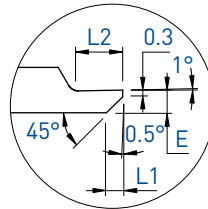
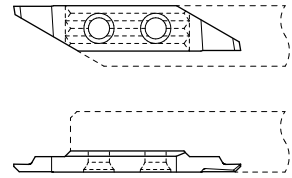

L

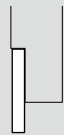

R



E	- L1	L2	Art. N°	TiALN	TiN	N (µk20)	HTA	HTiN	HN (µk10)	Art. N°	TiALN	TiN	N (µk20)	HTA	HTiN	HN (µk10)
0.8	0.5	1.6	713-45-0.8	■	■	■	■	□	■	723-45-0.8	■	■	■			
0.9	0.6	1.6	713-45-0.9	■	■	■				-						
1.0	0.7	2.0	713-45-1.0	■	■	■	■	□	■	723-45-1.0	■	□	■			
1.1	0.8	2.0	713-45-1.1	■	■	■				-						
1.2	0.9	2.5	713-45-1.2	■	■	■				723-45-1.2	■	■	■			
1.3	1.0	2.5	713-45-1.3	■	■	■				-						
1.4	1.1	3.0	713-45-1.4	■	■	■				-						
1.5	1.2	3.0	713-45-1.5	■	■	■	■	□	■	723-45-1.5	■	□	■			
1.8	1.5	4.0	713-45-1.8	■	■	■				723-45-1.8	■	□	■			
2.0	1.7	4.0	713-45-2.0	■	■	■				723-45-2.0	■	■	■			

# TOP-Line

Tourneur arrière  
Rückwärts drehen  
Back turning

713-60° / 723-60°

L

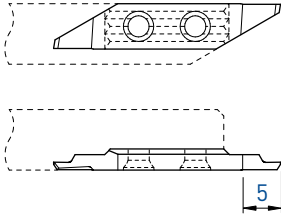

R

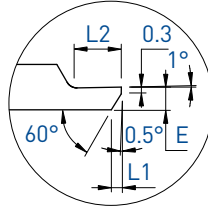
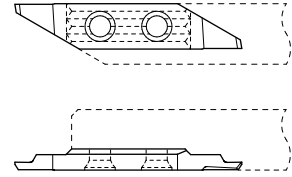

L



R



E	~ L1	L2	Art. N°	TiALN	TiN	N (µk20)	HTA	HTiN	HN (µk10)	Art. N°	TiALN	TiN	N (µk20)	HTA	HTiN	HN (µk10)
0.8	0.3	1.6	713-60-0.8	■	■	■				723-60-0.8	■	■	■			
0.9	0.35	1.6	713-60-0.9	■	■	■				-						
1.0	0.4	2.0	713-60-1.0	■	■	■				723-60-1.0	■	□	■			
1.1	0.45	2.0	713-60-1.1	■	■	■				-						
1.2	0.5	2.5	713-60-1.2	■	■	■				723-60-1.2	■	□	■			
1.3	0.6	2.5	713-60-1.3	■	■	■				-						
1.4	0.65	3.0	713-60-1.4	■	■	■				-						
1.5	0.7	3.0	713-60-1.5	■	■	■				723-60-1.5	■	■	■			
1.8	0.85	4.0	713-60-1.8	■	■	■				723-60-1.8	■	□	■			
2.0	1.0	4.0	713-60-2.0	■	■	■				723-60-2.0	■	■	■			

Foncer-tourner

Einstecken und drehen

Grooving and turning

714 / 724

L

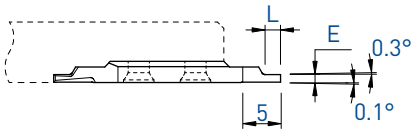
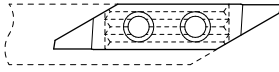

R

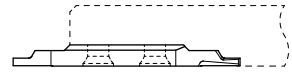
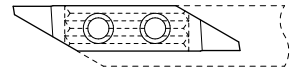

L

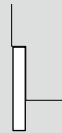

R



E	L	Art. N°	TiALN	TiN	N (µk20)	HTA	HTiN	HN (µk10)	Art. N°	TiALN	TiN	N (µk20)	HTA	HTiN	HN (µk10)
0.5	1.0	714-0.5	■	■	■				724-0.5	■	■	■	■	□	■
0.6	1.0	714-0.6	■	■	■				724-0.6	■	■	■			
0.7	1.5	714-0.7	■	■	■				724-0.7	■	■	■			
0.8	1.5	714-0.8	■	■	■	■	□	■	724-0.8	■	■	■			
0.9	2.0	714-0.9	■	■	■				724-0.9	■	□	■			
1.0	2.0	714-1.0	■	■	■	■	■	■	724-1.0	■	■	■			
1.1	2.0	714-1.1	■	■	■				724-1.1	■	□	■			
1.2	2.5	714-1.2	■	■	■				724-1.2	■	□	■			
1.3	2.5	714-1.3	■	■	■				724-1.3	■	■	■			
1.4	3.0	714-1.4	■	■	■				724-1.4	■	□	■			
1.5	3.0	714-1.5	■	■	■	■	■	■	724-1.5	■	■	■			

L

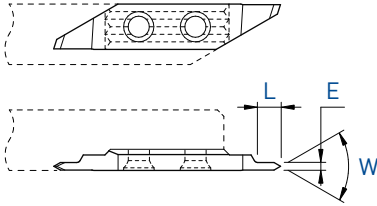

R

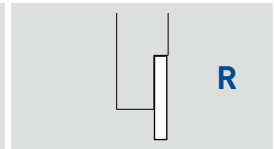
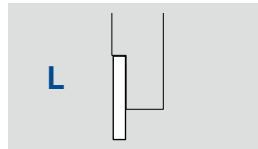
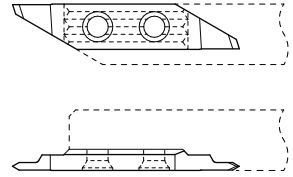

W	E	L	Art. N°	TiALN	TiN	N (µk20)	Art. N°	TiALN	TiN	N (µk20)
60°	1.0	3	716-60-1.0	■	■	■	726-60-1.0	■	■	■
60°	1.5	4	716-60-1.5	■	■	■	726-60-1.5	■	■	■
55°	1.0	3	716-55-1.0	■	■	■	726-55-1.0	■	□	■
55°	1.5	4	716-55-1.5	■	■	■	726-55-1.5	■	□	■

Plaquette ébauche

WSP-Rohling

Blank insert

## 711-EP / 721-EP

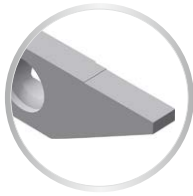
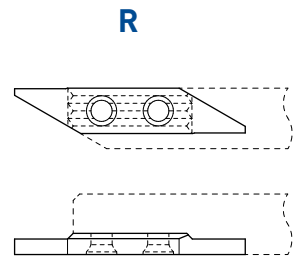
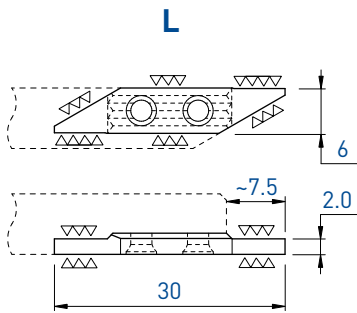

L		R			
Art. N°	TiALN TiN N (µk20)	HTA HTiN HN (µk10)	Art. N°	TiALN TiN N (µk20)	HTA HTiN HN (µk10)
711-EP	■ ■ ■	■ □ ■	721-EP	■ □ ■	□ □ ■

L			R			
Type		Page	Type		Page	
<b>730</b>	730	1.34	<b>740</b>	740	1.34	
	730-JET	1.38		740/730-D	1.37	
	730-NOVIBRA	1.39		740-C	1.35	
	730RC	1.36		740-JET	1.38	
<b>731</b>	731	1.40	740-NOVIBRA	1.39		
	731-E	1.74	<b>741</b>	741	1.40	
	731-EP	1.74		741-E	1.74	
	731N	1.46/1.53		741-EP	1.74	
	731R	1.47		741L	1.47	
	731RU	1.52		741LX12	1.50	
	731RX12	1.50		741LX25	1.51	
	731RX25	1.51		741LX4	1.48	
	731RX4	1.48		741LXF	1.49	
	731RXF	1.49		741N	1.46/1.53	
	731U	1.45		741U	1.45	
	731X12	1.43		741X12	1.43	
	731X25	1.44		741X25	1.44	
	731X4	1.41		741X4	1.41	
	731XF	1.42		741XF	1.42	
	<b>732</b>	732		1.54	<b>742</b>	742
732PX		1.55		742PX		1.55
732X		1.56	742X	1.56		
<b>733</b>	733	1.57	<b>743</b>	743	1.57	
	733P	1.63		743P	1.63	
	733VX-15°	1.61		743VX-15°	1.61	
	733VX-8°	1.59		743VX-8°	1.59	
	733VX-805	1.60		743VX-805	1.60	
	733X	1.58		743X	1.58	
	733ZX10	1.62		743ZX10	1.62	
<b>734</b>	734	1.64	<b>744</b>	744	1.64	
	734VS	1.65		744VS	1.65	
	734X	1.66		744X	1.66	
	734ZX10	1.67		744ZX10	1.67	
<b>735</b>	735	1.69	744ZX17	1.67		
<b>736</b>	736-60	1.70	744ZXT	1.68		
	736-A60°	1.71	<b>745</b>	745	1.69	
736-M	1.72	<b>746</b>		746-60	1.70	
<b>737</b>	737		1.73	746-A60°	1.71	
			746-M	1.72		
			<b>747</b>	747	1.73	

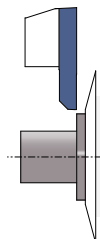
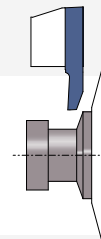
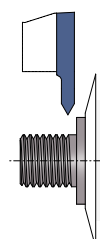
		<b>730 / 740</b> Porte-outils Halter Holders	>	<b>1.34</b>
	<b>731 / 741</b> Tronçonnage Abstechen Parting off		>	<b>1.40</b>
				
		<b>741L / 731R</b> Tronçonnage - coupe déportée Abstechen - versetztes Schneiden Parting off - cut off line	>	<b>1.47</b>
	<b>732 / 742</b> Tourneur avant Vorwärts drehen Front turning		>	<b>1.54</b>
				
		<b>733 / 743</b> Tourneur arrière Rückwärts drehen Back turning	>	<b>1.57</b>
	<b>734 / 744</b> Foncer-tourner Einstecken und drehen Grooving and turning		>	<b>1.64</b>
				
		<b>735 / 745</b> Gorge Einstecken Grooving	>	<b>1.69</b>
	<b>736 / 746</b> Fileter Gewinde drehen Threading		>	<b>1.70</b>
				
		<b>737 / 747</b> Plaquettes à rayon Radius Wendepplatten Inserts with radius	>	<b>1.73</b>
		<b>Plaquette ébauche</b> WSP-Rohling Blank insert	>	<b>1.74</b>

L

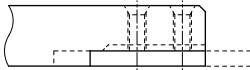
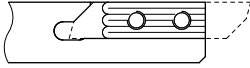

R

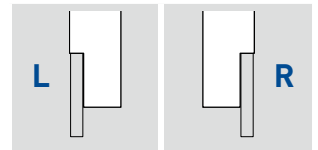
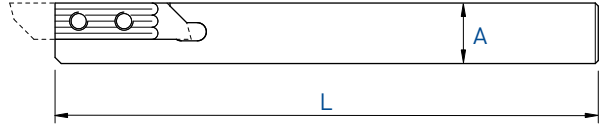

Serrage standard A  
Standard Spannsystem A  
Standard clamping system A

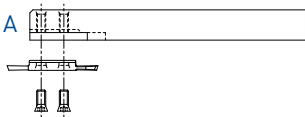

Serrage B  
Spannsystem B  
Clamping system B

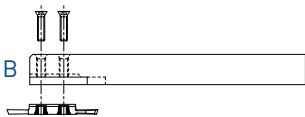

A x B	L	Serrage Spannsystem Clamping	Art. N°	Art. N°
7 x 7	115	A	<b>730-7</b>	<b>740-7</b>
8 x 8	115	A + B	<b>730-8</b>	<b>740-8</b>
8 x 8	140	A + B	<b>730-8-140</b>	-
10 x 10	115	A + B	<b>730-10</b>	<b>740-10</b>
10 x 10	50	A + B	<b>730-10-50</b>	<b>740-10-50</b>
12 x 12	130	A + B	<b>730-12</b>	<b>740-12</b>
12 x 12	90	A + B	<b>730-12-90</b>	<b>740-12-90</b>
12.7 x 12.7	130	A + B	<b>730-12.7</b>	<b>740-12.7</b>
16 x 16	130	A + B	<b>730-16</b>	<b>740-16</b>
16 x 16	75	A + B	<b>730-16-75</b>	<b>740-16-75</b>
20 x 20	120	A + B	<b>730-20</b>	<b>740-20</b>

Chaque support est livré avec vis et clé.  
Jeder Halter wird mit Spannschraube(n) und Schlüssel geliefert.  
Screw(s) and key are included with each tool holder.



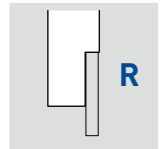
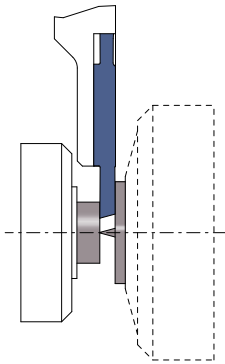
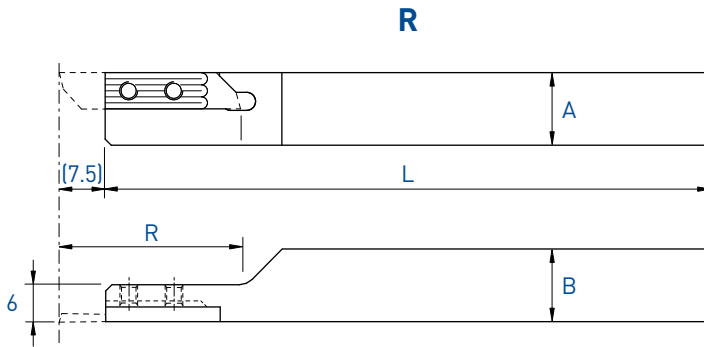

A x B	L	R	Serrage Spannsystem Clamping	Art. N°
8 x 8	115	24	A	<b>740-C-8</b>
10 x 10	115	24	A	<b>740-C-10</b>
12 x 12	130	30	A	<b>740-C-12</b>
16 x 16	130	40	A	<b>740-C-16</b>

Chaque support est livré avec vis et clé.  
 Jeder Halter wird mit Spannschraube(n) und Schlüssel geliefert.  
 Screw(s) and key are included with each tool holder.

Porte-outils

Halter

Holder's

Coupe à droite déportée

Versetztes Rechtsschneiden

Right cut off line

**730RC**

Utiliser des plaquettes type 731R  
WSP Typ 731R verwenden  
Use inserts type 731R

Voir pages 1.47 - 1.53  
Siehe Seiten 1.47 - 1.53  
See pages 1.47 - 1.53

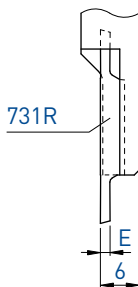
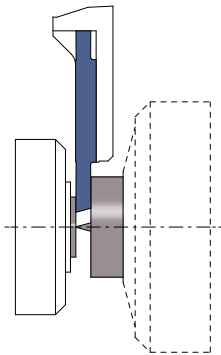
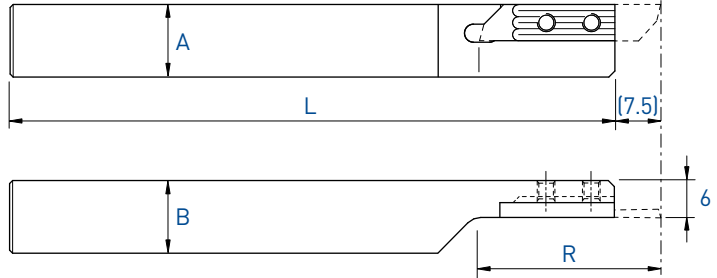

**L (R)**

Coupe à droite déportée  
Versetztes Rechtsschneiden  
Right cut off line

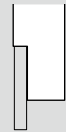

A x B	L	R	Art. N°
8 x 8	115	24	<b>730RC-8</b>
10 x 10	115	24	<b>730RC-10</b>
12 x 12	130	30	<b>730RC-12</b>
16 x 16	130	40	<b>730RC-16</b>

Chaque support est livré avec vis et clé.  
Jeder Halter wird mit Spannschraube(n) und Schlüssel geliefert.  
Screw(s) and key are included with each tool holder.

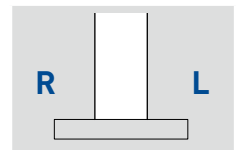
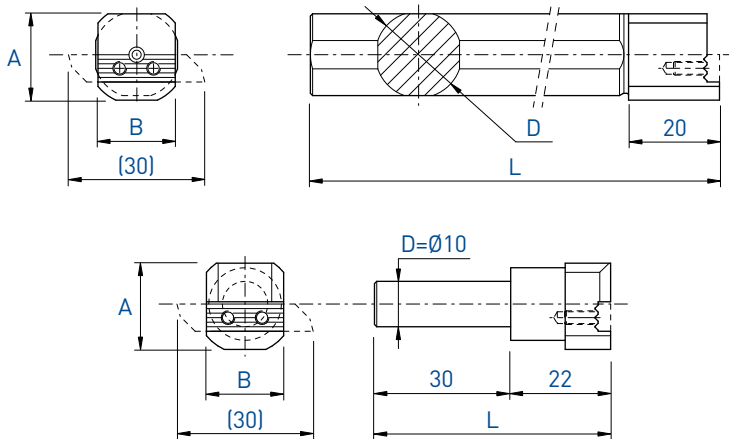

D	L	A	B	Art. N°
10	52	19	17	<b>740/730-D10</b>
16	160	19	17	<b>740/730-D16</b>
19.05	160	19	17	<b>740/730-D19.05</b>
19.05	110	19	17	<b>740/730-D19.05-S</b>
20	160	19.5	17	<b>740/730-D20</b>
22	110	20	17	<b>740/730-D22</b>
25	200	22	17	<b>740/730-D25</b>
25.4	200	22	17	<b>740/730-D25.4</b>

Chaque support est livré avec vis et clé.  
 Jeder Halter wird mit Spannschraube(n) und Schlüssel geliefert.  
 Screw(s) and key are included with each tool holder.

# TOP-Line

Porte-outils avec arrosage intégré

Halter mit integriertem Kühlmittelzufuhr

Holder with integrated coolant supply

## 730-JET / 740-JET

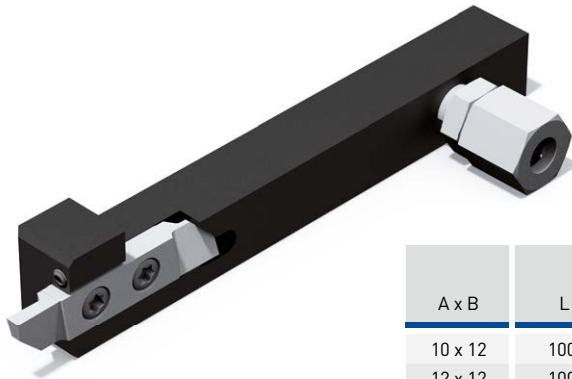
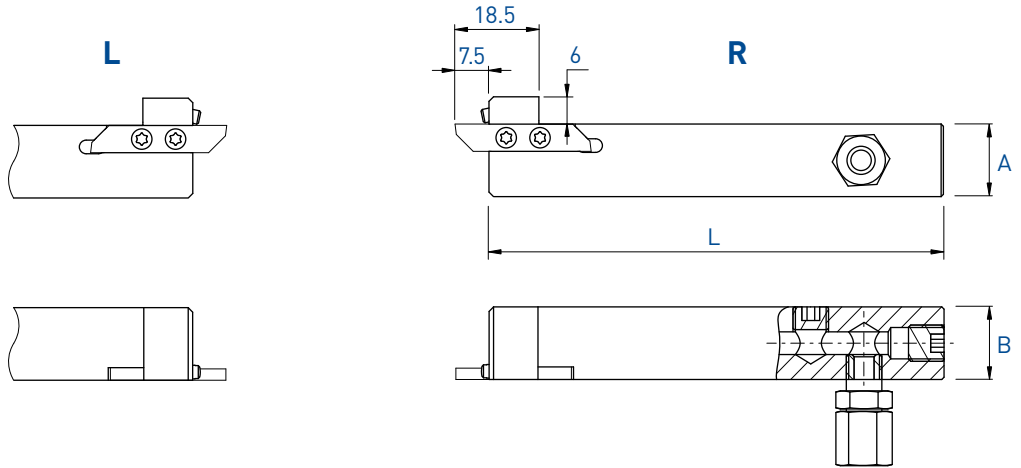

**NEW**

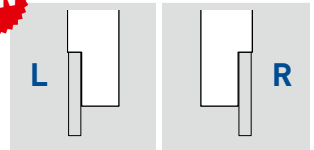

A x B	L	Serrage Spannsystem Clamping	Art. N°	Art. N°
10 x 12	100	A + B	730-1012-JET	740-1012-JET
12 x 12	100	A + B	730-12-JET	740-12-JET
12.7 x 12.7	100	A + B	730-12.7-JET	740-12.7-JET
16 x 16	100	A + B	730-16-JET	740-16-JET
20 x 20	100	A + B	730-20-JET	740-20-JET

Pièces de rechange  
Ersatzteile  
Spare parts



Art. N°

730-JET / 740-JET

J-M8X1-D6



Art. N°

JB-M8X1

Buse  
Düse  
Nozzle



Art. N°

JJ-M3X6-D1.5

Chaque support est livré avec vis et clé.  
Jeder Halter wird mit Spannschraube(n) und Schlüssel geliefert.  
Screw(s) and key are included with each tool holder.

Porte-outils en métal lourd anti-vibratoire

Schwingungsdämpfende Schwermetallhalter

Low vibration heavy metal holders

**730-NOVIBRA**  
**740-NOVIBRA**

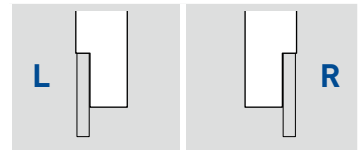
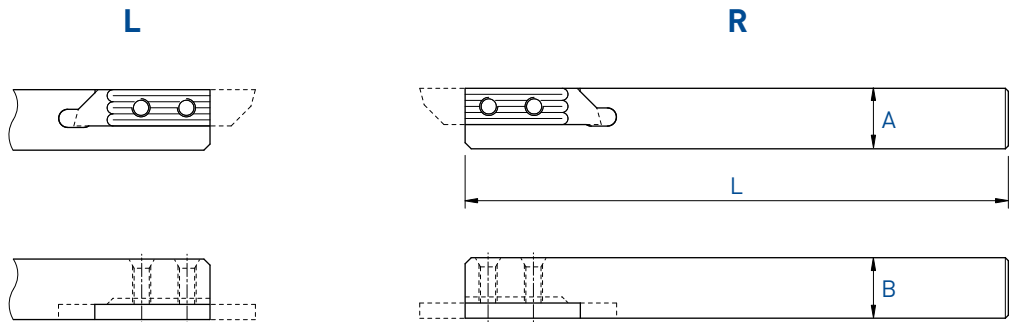

A x B	L	Serrage Spannsystem Clamping	Art. N°	Art. N°
7 x 7	115	A	<b>730-7-NOVIBRA</b>	<b>740-7-NOVIBRA</b>
8 x 8	115	A + B	<b>730-8-NOVIBRA</b>	<b>740-8-NOVIBRA</b>
10 x 10	115	A + B	-	<b>740-10-NOVIBRA</b>
12 x 12	130	A + B	-	<b>740-12-NOVIBRA</b>

Chaque support est livré avec vis et clé.  
Jeder Halter wird mit Spannschraube(n) und Schlüssel geliefert.  
Screw(s) and key are included with each tool holder.

L

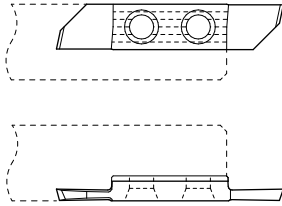

R

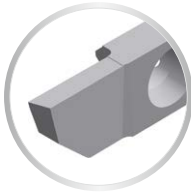
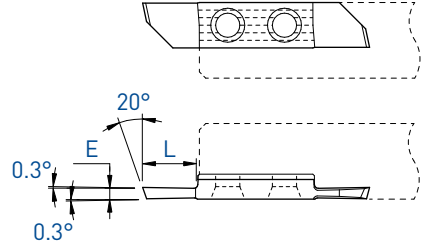

L

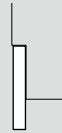

R



E	L	Art. N°	TiALN	TiN	N (µk20)	HTA	HTiN	HN (µk10)	Art. N°	TiALN	TiN	N (µk20)	HTA	HTiN	HN (µk10)
0.8	5	731-0.8	■	■	■	■	□	■	741-0.8	■	■	■	■	■	■
1.0	5	731-1.0	■	■	■	■	■	■	741-1.0	■	■	■	■	■	■
1.2	5	731-1.2	■	■	■	■	□	■	741-1.2	■	■	■	■	■	■
1.5	7	731-1.5	■	■	■	■	■	■	741-1.5	■	■	■	■	■	■
1.8	7	731-1.8	■	■	■	■	□	■	741-1.8	■	■	■	■	□	■
2.0	7	731-2.0	■	■	■	■	□	■	741-2.0	■	■	■	■	■	■
2.5	7	731-2.5	■	■	■				741-2.5	■	■	■	■	□	■

7XX-XX-B



Sur demande pour serrage type B, voir page 1.03  
Wahlweise für B-Spannsystem, siehe Seite 1.03  
On request for B clamping system, see page 1.03

Tronçonnage

Abstechen

Parting off

## 731X4 / 741X4

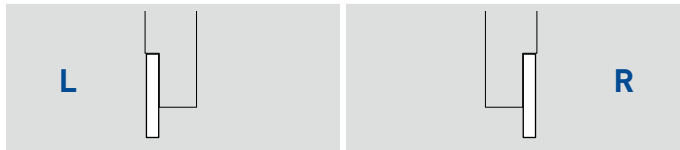
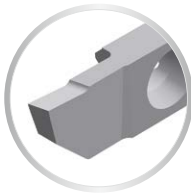
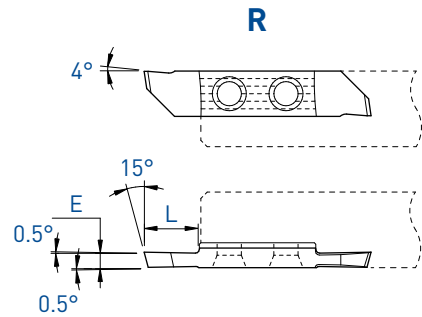
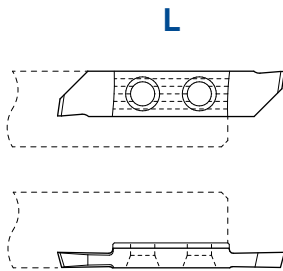

E	L	Art. N°	L			R		
			TiALN	TiN	N (µk20)	HTA	HTiN	HN (µk10)
1.0	5	731X4-1.0	■	■	■			
1.5	7	731X4-1.5	■	■	■	■	□	■
2.0	7	731X4-2.0	■	■	■			

7XX-XX-B



Sur demande pour serrage type B, voir page 1.03  
Wahlweise für B-Spannsystem, siehe Seite 1.03  
On request for B clamping system, see page 1.03

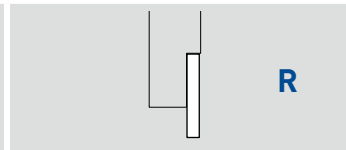
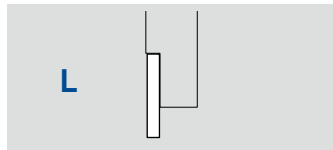
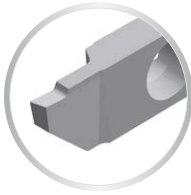
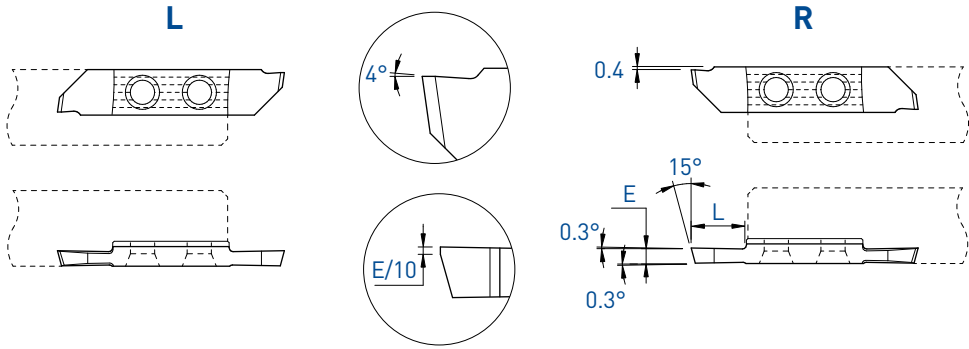

E	L	Art. N°	TiALN	TiN	N (µk20)	HTA	HTiN	HN (µk10)	Art. N°	TiALN	TiN	N (µk20)	HTA	HTiN	HN (µk10)
1.2	7	-							741XF-1.2	■	□	■			
1.5	7	731XF-1.5	■	■	■	■	■	■	741XF-1.5	■	■	■	■	■	■
2.0	7	731XF-2.0	■	■	■				741XF-2.0	■	■	■	■	■	■
2.5	7	731XF-2.5	■	■	■				741XF-2.5	■	■	■			

7XX-XX-B



Sur demande pour serrage type B, voir page 1.03  
Wahlweise für B-Spannsystem, siehe Seite 1.03  
On request for B clamping system, see page 1.03



Tronçonnage

Abstechen

Parting off

## 731X12 / 741X12

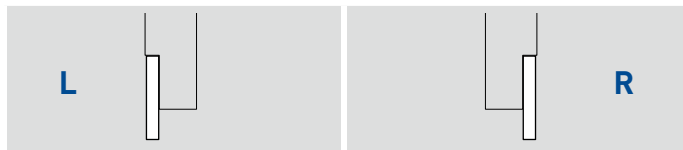
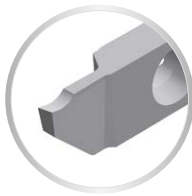
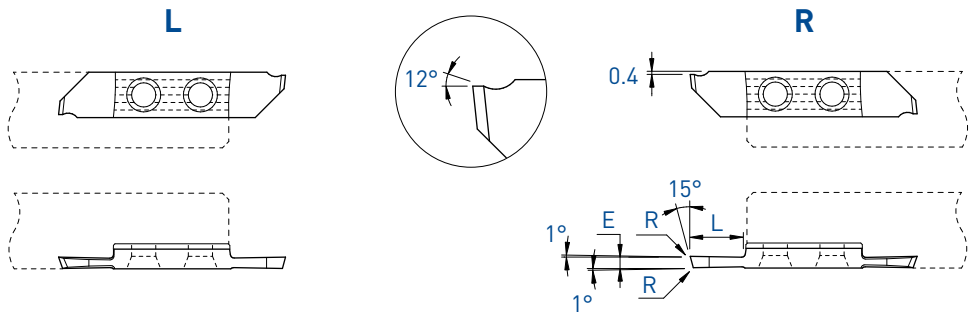

E	L	R	Art. N°	TiALN	TiN	N (µk20)	HTA	HTiN	HN (µk10)	Art. N°	TiALN	TiN	N (µk20)	HTA	HTiN	HN (µk10)
1.0	5	0.03	731X12-1.0	■	■	■				741X12-1.0	■	■	■	■	□	■
1.5	7	0.03	731X12-1.5	■	■	■				741X12-1.5	■	■	■	■	■	■
2.0	7	0.03	731X12-2.0	■	■	■				741X12-2.0	■	■	■			

7XX-XX-B



Sur demande pour serrage type B, voir page 1.03  
Wahlweise für B-Spannsystem, siehe Seite 1.03  
On request for B clamping system, see page 1.03

Tronçonnage

Abstechen

Parting off

## 731X25 / 741X25

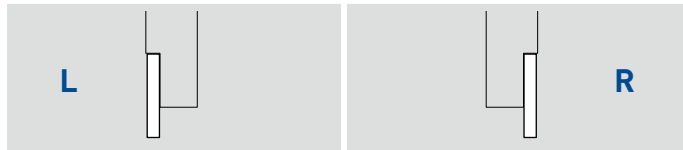
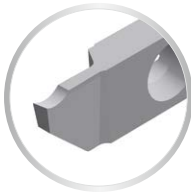
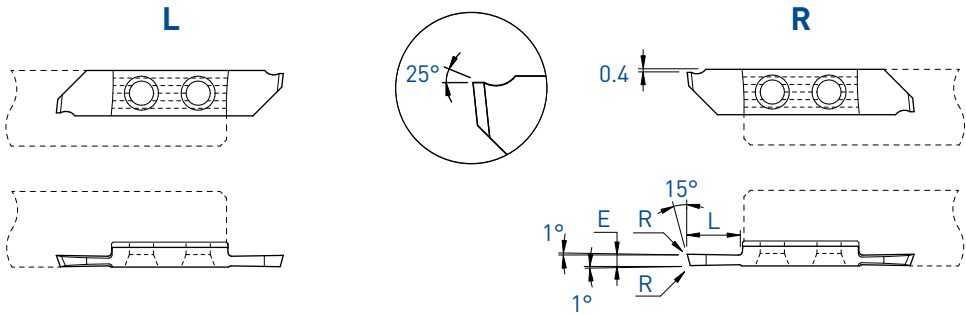

E	L	R	Art. N°	TiALN	TiN	N (µm20)	HTA	HTiN	HN (µm10)	Art. N°	TiALN	TiN	N (µm20)	HTA	HTiN	HN (µm10)
1.0	5	0.03	731X25-1.0	■	■	■				741X25-1.0	■	■	■	■	□	■
1.5	7	0.03	731X25-1.5	■	■	■				741X25-1.5	■	■	■	■	□	■
2.0	7	0.03	731X25-2.0	■	■	■				741X25-2.0	■	■	■	■	□	■

7XX-XX-B



Sur demande pour serrage type B, voir page 1.03  
Wahlweise für B-Spannsystem, siehe Seite 1.03  
On request for B clamping system, see page 1.03

Tronçonnage

Abstechen

Parting off

## 731U / 741U

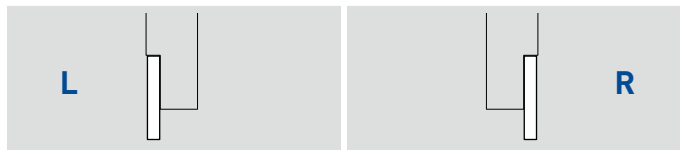
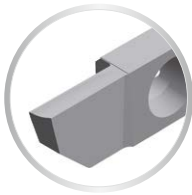
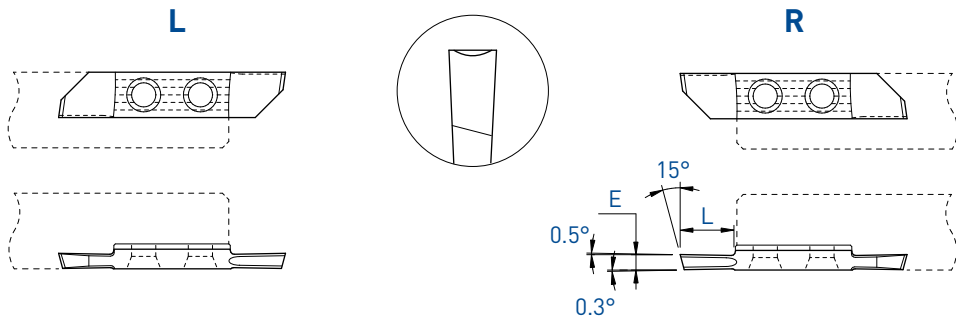

E	L	Art. N°	TiAlN			HTA			Art. N°	TiAlN			HTA		
			TiN	N (µk20)	HN (µk10)	HTiN	HN (µk10)	TiN		N (µk20)	HTiN	HN (µk10)			
1.5	7	731U-1.5	■	■	■	■	□	■	741U-1.5	■	■	■	■	■	■
2.0	7	731U-2.0	■	■	■	■	□	■	741U-2.0	■	■	■	■	□	■

7XX-XX-B



Sur demande pour serrage type B, voir page 1.03  
Wahlweise für B-Spannsystem, siehe Seite 1.03  
On request for B clamping system, see page 1.03

Tronçonnage

Abstechen

Parting off

731N / 741N

L

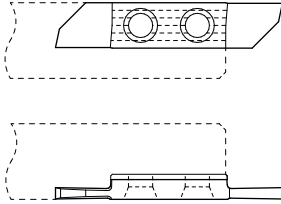

R

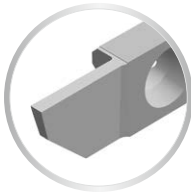
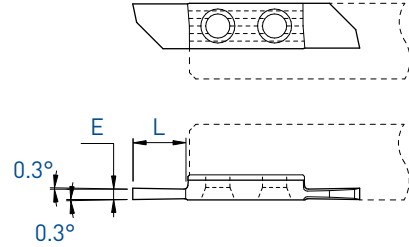

L

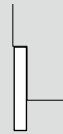

R



E	L	Art. N°	TiALN	TiN	N (µk20)	HTA	HTiN	HN (µk10)	Art. N°	TiALN	TiN	N (µk20)	HTA	HTiN	HN (µk10)
1.0	5	731N-1.0	■	■	■	■	□	■	741N-1.0	■	■	■	■	□	■
1.5	7	731N-1.5	■	■	■	■	□	■	741N-1.5	■	■	■	■	□	■

7XX-XX-B



Sur demande pour serrage type B, voir page 1.03  
Wahlweise für B-Spannsystem, siehe Seite 1.03  
On request for B clamping system, see page 1.03

Tronçonnage

Coupe déportée

Abstechen

Versetztes Schneiden

Parting off

Cut off line

741L / 731R

Cut L

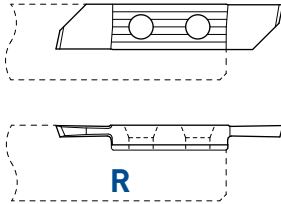

Cut R

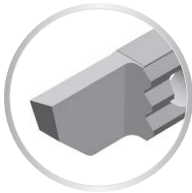
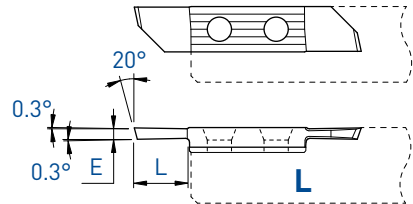

R (L)

Coupe à gauche déportée  
Versetztes Linksschneiden  
Left cut off line

L (R)

Coupe à droite déportée  
Versetztes Rechtsschneiden  
Right cut off line

E	L	Art. N°	TiALN	TiN	N (µk20)	HTA	HTiN	HN (µk10)	Art. N°	TiALN	TiN	N (µk20)	HTA	HTiN	HN (µk10)
1.0	5	741L-1.0	■	■	■	■	□	■	731R-1.0	■	■	■	■	■	■
1.2	5	741L-1.2	■	■	■	■	□	■	731R-1.2	■	■	■	■	□	■
1.5	7	741L-1.5	■	■	■	■	■	■	731R-1.5	■	■	■	■	■	■
2.0	7	741L-2.0	■	■	■	■	□	■	731R-2.0	■	■	■	■	□	■
2.5	7	741L-2.5	■	■	■				731R-2.5	■	■	■			

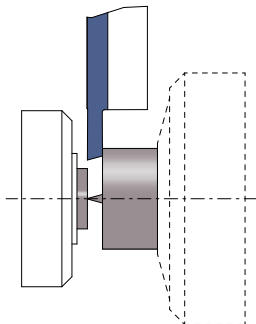

Tronçonnage

Abstechen

Parting off

Coupe déportée

Versetztes Schneiden

Cut off line

## 741LX4 / 731RX4

### Cut L

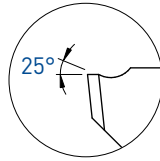
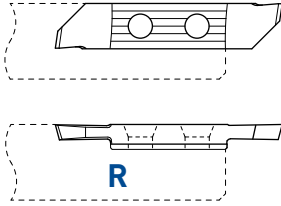

### Cut R

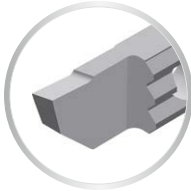
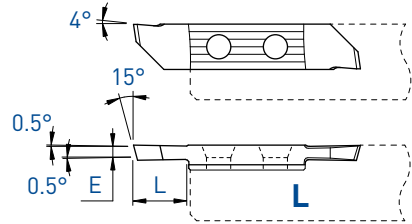

### R (L)

Coupe à gauche déportée  
Versetztes Linksschneiden  
Left cut off line



### L (R)

Coupe à droite déportée  
Versetztes Rechtsschneiden  
Right cut off line



E	L	Art. N°	TiALN	TiN	N (µk20)	HTA	HTiN	HN (µk10)	Art. N°	TiALN	TiN	N (µk20)	HTA	HTiN	HN (µk10)
1.0	5	741LX4-1.5	■	■	■				731RX4-1.5	■	■	■	□	■	■

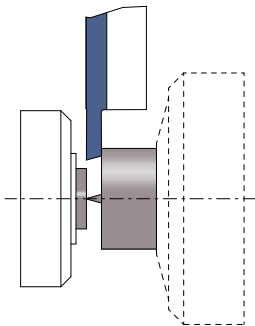

Tronçonnage

Coupe déportée

Abstechen

Versetztes Schneiden

Parting off

Cut off line

## 741LXF / 731RXF

### Cut L

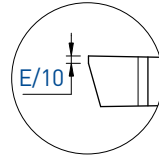
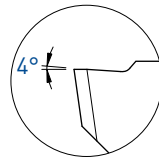
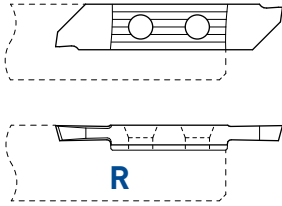

### Cut R

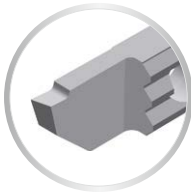
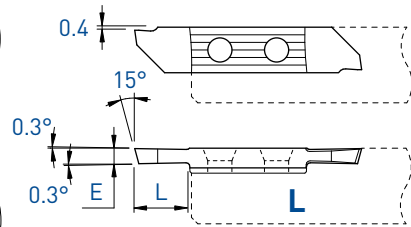

### R (L)

Coupe à gauche déportée  
Versetztes Linksschneiden  
Left cut off line

### L (R)

Coupe à droite déportée  
Versetztes Rechtsschneiden  
Right cut off line

E	L	Art. N°	TiALN	TiN	N (µk20)	HTA	HTiN	HN (µk10)	Art. N°	TiALN	TiN	N (µk20)	HTA	HTiN	HN (µk10)
1.5	7	741LXF-1.5	■	■	■				731RXF-1.5	■	■	■	■	□	■
2.0	7	741LXF-2.0	■	■	■				731RXF-2.0	■	■	■	■	□	■
2.5	7	741LXF-2.5	■	■	■				731RXF-2.5	■	■	■	■		

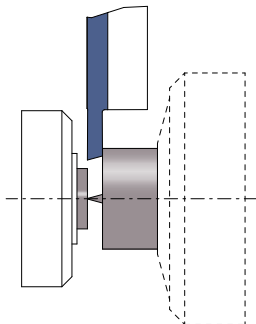

Tronçonnage

Abstechen

Parting off

Coupe déportée

Versetztes Schneiden

Cut off line

## 741LX12 / 731RX12

Cut L

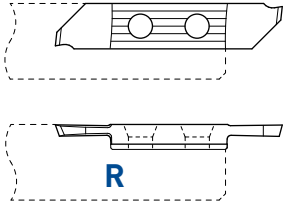

Cut R

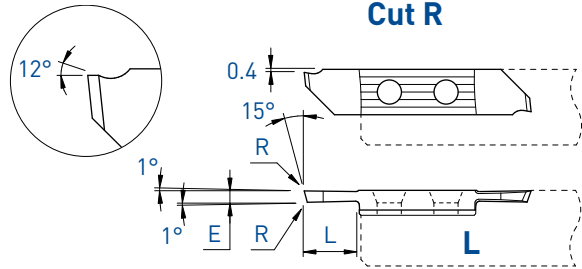

**R (L)**

Coupe à gauche déportée  
Versetztes Linksschneiden  
Left cut off line

**L (R)**

Coupe à droite déportée  
Versetztes Rechtsschneiden  
Right cut off line

E	L	R	Art. N°	TiALN	TiN	N (µk20)	HTA	HTiN	HN (µk10)	Art. N°	TiALN	TiN	N (µk20)	HTA	HTiN	HN (µk10)
1	5	0.03	-							731Rx12-1.0	■	□	■			
1.5	7	0.03	741LX12-1.5	■	■	■				731Rx12-1.5	■	■	■	■	■	■

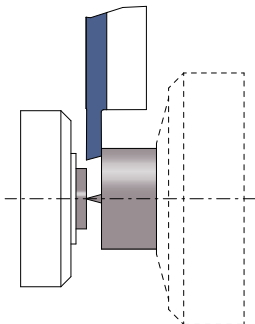



Tronçonnage

Coupe déportée

Abstechen

Versetztes Schneiden

Parting off

Cut off line

## 741LX25 / 731RX25

### Cut L

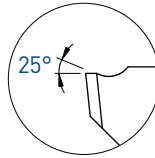
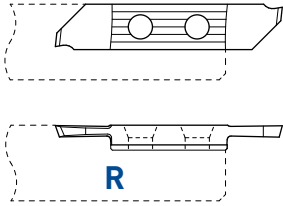

### Cut R

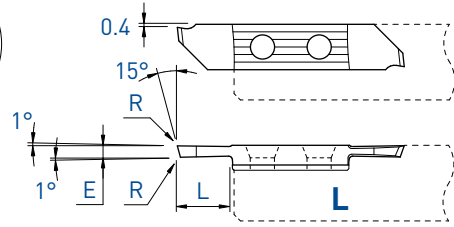

### R (L)

Coupe à gauche déportée  
Versetztes Linksschneiden  
Left cut off line

### L (R)

Coupe à droite déportée  
Versetztes Rechtsschneiden  
Right cut off line

E	L	R	Art. N°	TiALN	TiN	N (µk20)	HTA	HTiN	HN (µk10)	Art. N°	TiALN	TiN	N (µk20)	HTA	HTiN	HN (µk10)
1.5	7	0.03	741LX25-1.5	■	■	■				731RX25-1.5	■	■	■			

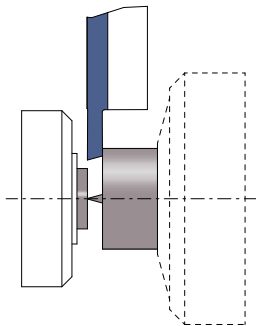

Tronçonnage

Abstechen

Parting off

Coupe déportée

Versetztes Schneiden

Cut off line

731RU

## Cut R

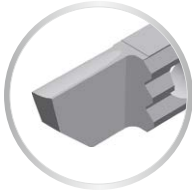
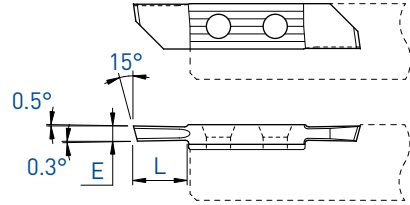
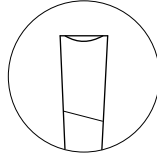

**NEW**

## L (R)

Coupe à droite déportée  
Versetztes Rechtsschneiden  
Right cut off line

E	L	Art. N°	TiALN	TiN	N (µk20)	HTA	HTiN	HN (µk10)
1.0	5	731RU-1.0	■	□	■	□	□	□
1.2	5	731RU-1.2	■	□	■			
1.5	7	731RU-1.5	■	□	■	□	□	□
2.0	7	731RU-2.0	■	□	■			

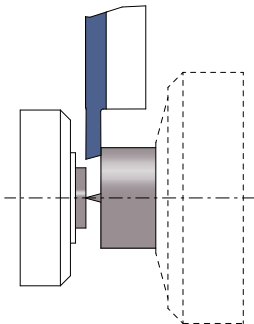

Tronçonnage

Coupe déportée

Abstechen

Versetztes Schneiden

Parting off

Cut off line

741N / 731N

## Cut L

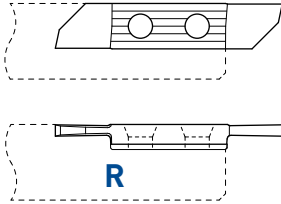

## Cut R

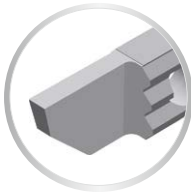
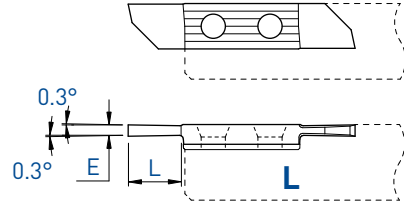

### R (L)

Coupe à gauche déportée  
Versetztes Linksschneiden  
Left cut off line

### L (R)

Coupe à droite déportée  
Versetztes Rechtsschneiden  
Right cut off line

E	L	Art. N°	TiALN	TiN	N (µk20)	HTA	HTiN	HN (µk10)	Art. N°	TiALN	TiN	N (µk20)	HTA	HTiN	HN (µk10)
1.0	5	741N-1.0	■	■	■	■	□	■	731N-1.0	■	■	■	■	□	■
1.5	7	741N-1.5	■	■	■	■	□	■	731N-1.5	■	■	■	■	□	■

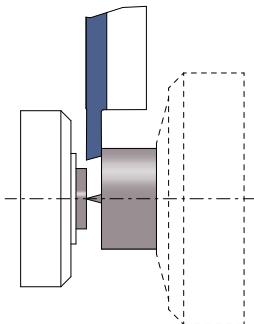

# TOP-Line

Tourneur avant  
Vorwärts drehen  
Front turning

732 / 742

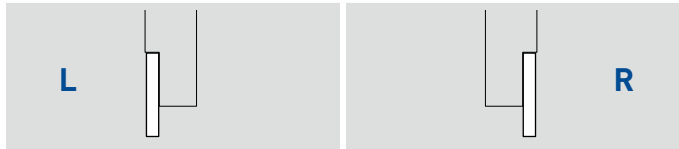
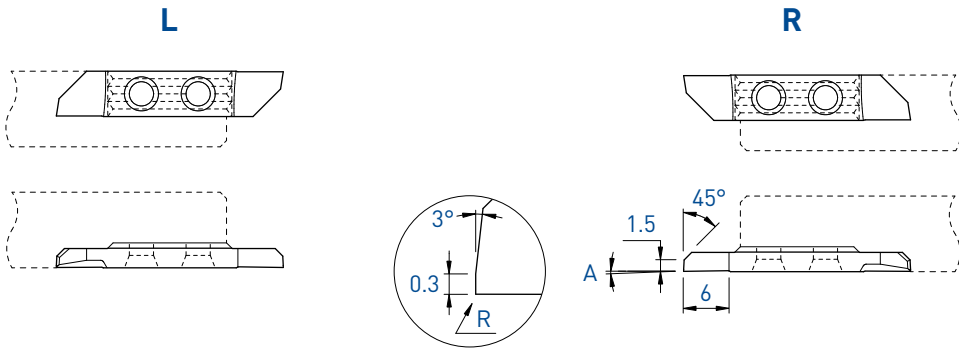

A	R	Art. N°	TiALN	TiN	N (µk20)	HTA	HTiN	HN (µk10)	Art. N°	TiALN	TiN	N (µk20)	HTA	HTiN	HN (µk10)
0°	0	732	■	■	■	■	■	■	742	■	■	■	■	■	■
2°	0	732-2°	■	■	■	■	□	■	742-2°	■	■	■	■	■	■

7XX-XX-B



Sur demande pour serrage type B, voir page 1.03  
Wahlweise für B-Spannsystem, siehe Seite 1.03  
On request for B clamping system, see page 1.03

Tourneur avant  
Vorwärts drehen  
Front turning

## 732PX / 742PX

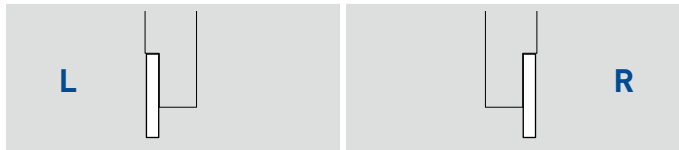
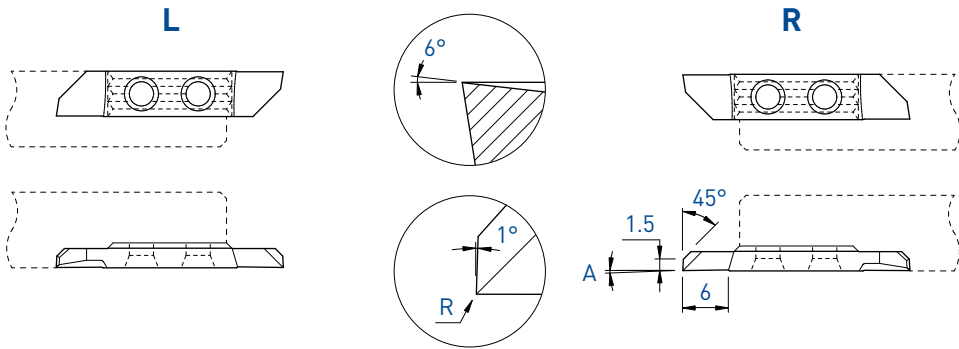

A	R	Art. N°	TiALN	TiN	N (µk20)	HTA	HTiN	HN (µk10)	Art. N°	TiALN	TiN	N (µk20)	HTA	HTiN	HN (µk10)
0°	0	732PX	■	■	■				742PX	■	■	■			

7XX-XX-B



Sur demande pour serrage type B, voir page 1.03  
Wahlweise für B-Spannsystem, siehe Seite 1.03  
On request for B clamping system, see page 1.03

# TOP-Line

Tourneur avant  
Vorwärts drehen  
Front turning

732X / 742X

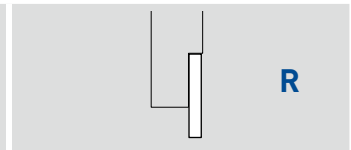
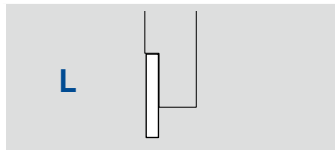
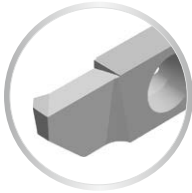
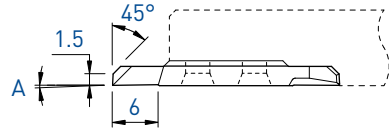
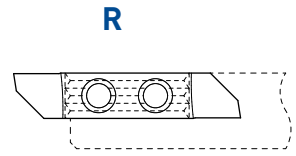
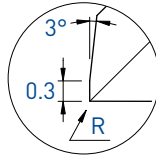
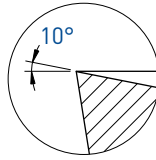
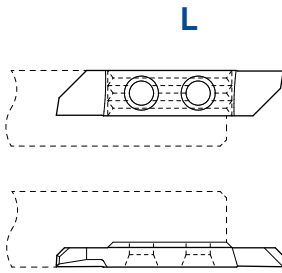

A	R	Art. N°	TiALN	TiN	N (µk20)	HTA	HTiN	HN (µk10)	Art. N°	TiALN	TiN	N (µk20)	HTA	HTiN	HN (µk10)
0°	0	732X	■	■	■	■	■	■	742X	■	■	■	■	■	■

7XX-XX-B



Sur demande pour serrage type B, voir page 1.03  
Wahlweise für B-Spannsystem, siehe Seite 1.03  
On request for B clamping system, see page 1.03

**Tourneur arrière**  
**Rückwärts drehen**  
**Back turning**

**733 / 743**

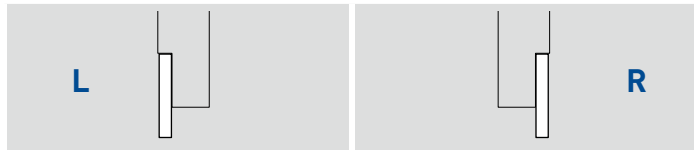
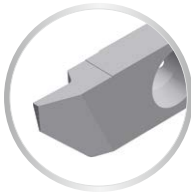
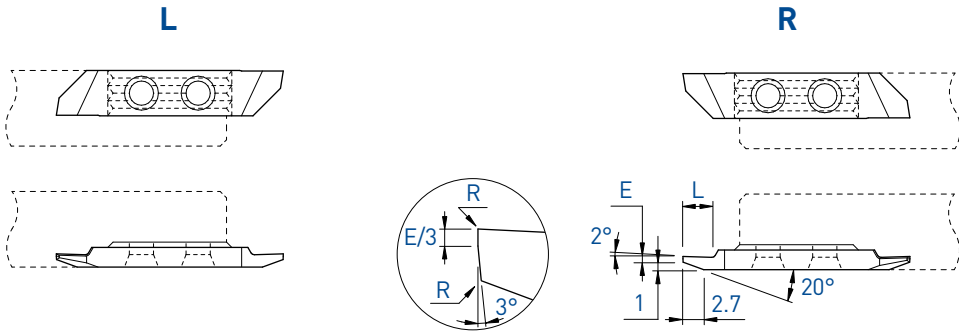

E	L	R	Art. N°	TiALN	TiN	N (µk20)	HTA	HTiN	HN (µk10)	Art. N°	TiALN	TiN	N (µk20)	HTA	HTiN	HN (µk10)
0.5	3	0	733-0.5	■	■	■	■	□	■	743-0.5	■	■	■	■	■	■
0.5	3	0.08	733-0.5-R08	■	■	■				743-0.5-R08	■	■	■	■	□	■
0.8	4	0	733-0.8	■	■	■				743-0.8	■	■	■	■	□	■
1.0	4	0	733-1.0	■	■	■	■	□	■	743-1.0	■	■	■	■	□	■
1.2	5	0	733-1.2	■	■	■	■	□	■	743-1.2	■	■	■			
1.5	6	0	733-1.5	■	■	■	■	□	■	743-1.5	■	■	■	■	□	■

**7XX-XX-B**



Sur demande pour serrage type B, voir page 1.03  
 Wahlweise für B-Spannsystem, siehe Seite 1.03  
 On request for B clamping system, see page 1.03

# TOP-Line

Tourneur arrière  
Rückwärts drehen  
Back turning

733X / 743X

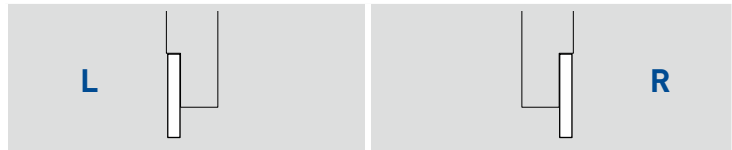
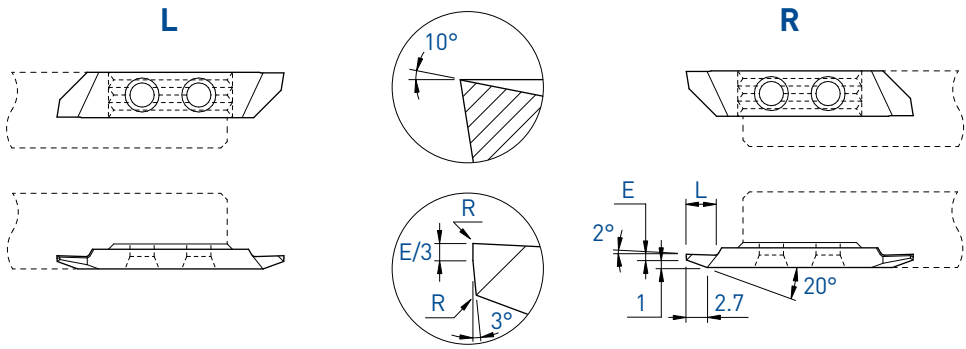

E	L	R	Art. N°	TiALN	TiN	N (µk20)	HTA	HTiN	HN (µk10)	Art. N°	TiALN	TiN	N (µk20)	HTA	HTiN	HN (µk10)
0.5	3	0	733x-0.5	■	■	■	■	□	■	743x-0.5	■	■	■	■	□	■
0.5	3	0.08	733x-0.5-R08	■	■	■				743x-0.5-R08	■	■	■	■	□	■
0.8	4	0	733x-0.8	■	■	■				743x-0.8	■	■	■	■	□	■
1.0	4	0	733x-1.0	■	■	■				743x-1.0	■	■	■	■	□	■
1.2	5	0	733x-1.2	■	■	■				743x-1.2	■	■	■	■	□	■
1.5	6	0	733x-1.5	■	■	■				743x-1.5	■	■	■	■	□	■

7XX-XX-B



Sur demande pour serrage type B, voir page 1.03  
Wahlweise für B-Spannsystem, siehe Seite 1.03  
On request for B clamping system, see page 1.03



Tourneur arrière  
Rückwärts drehen  
Back turning

## 733VX-8° / 743VX-8°

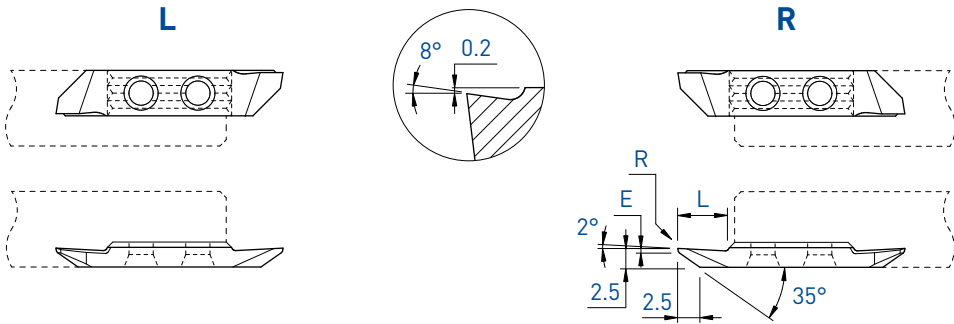

			L						R							
E	L	R	Art. N°	TiALN	TiN	N (µk20)	HTA	HTiN	HN (µk10)	Art. N°	TiALN	TiN	N (µk20)	HTA	HTiN	HN (µk10)
~ 1.0	6.5	0	733VX-8°	■	■	■	■	□	■	743VX-8°	■	■	■	■	■	■
~ 1.0	6.5	0.08	733VX-8°-R08	■	■	■	■	□	■	743VX-8°-R08	■	■	■	■	□	■

7XX-XX-B



Sur demande pour serrage type B, voir page 1.03  
Wahlweise für B-Spannsystem, siehe Seite 1.03  
On request for B clamping system, see page 1.03

# TOP-Line

Tourneur arrière  
Rückwärts drehen  
Back turning

733VX-805 / 743VX-805

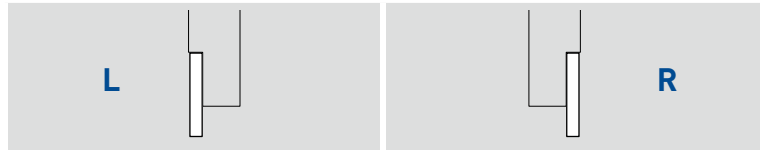
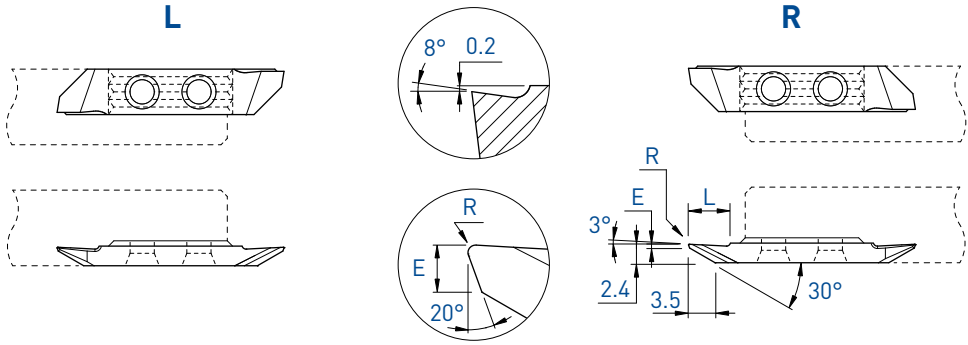

E	L	R	Art. N°	TiALN	TiN	N (µk20)	HTA	HTiN	HN (µk10)	Art. N°	TiALN	TiN	N (µk20)	HTA	HTiN	HN (µk10)
0.5	6	0.08	733VX-805-R08	■	□	■	■	□	■	743VX-805-R08	■	■	■	■	□	■

7XX-XX-B



Sur demande pour serrage type B, voir page 1.03  
Wahlweise für B-Spannsystem, siehe Seite 1.03  
On request for B clamping system, see page 1.03

Tourneur arrière  
Rückwärts drehen  
Back turning

## 733VX-15° / 743VX-15°

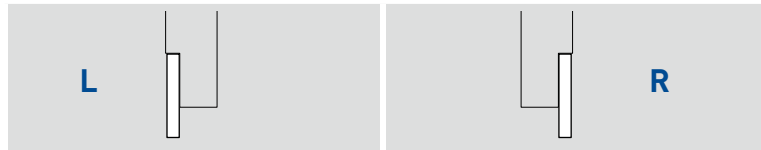
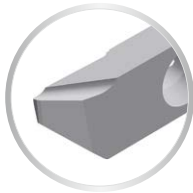
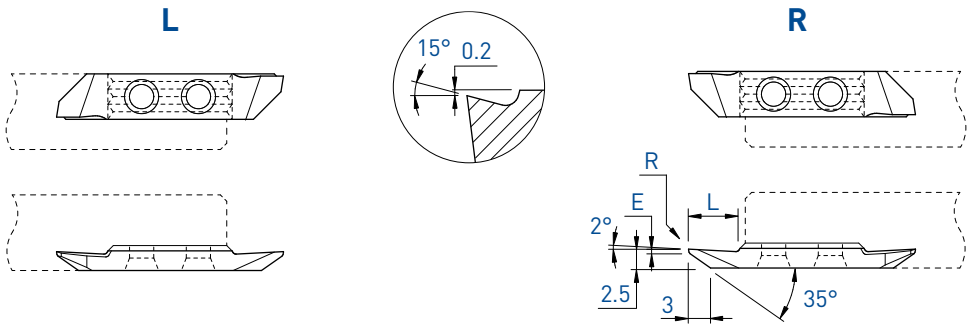

E	L	R	Art. N°	TiALN	TiN	N (µk20)	HTA	HTiN	HN (µk10)	Art. N°	TiALN	TiN	N (µk20)	HTA	HTiN	HN (µk10)
0.5	6.5	0	733VX-15°	■	■	■	■	□	■	743VX-15°	■	■	■	■	□	■
0.5	6.5	0.08	733VX-15°-R08	■	■	■				743VX-15°-R08	■	■	■	■	□	■

7XX-XX-B



Sur demande pour serrage type B, voir page 1.03  
Wahlweise für B-Spannsystem, siehe Seite 1.03  
On request for B clamping system, see page 1.03

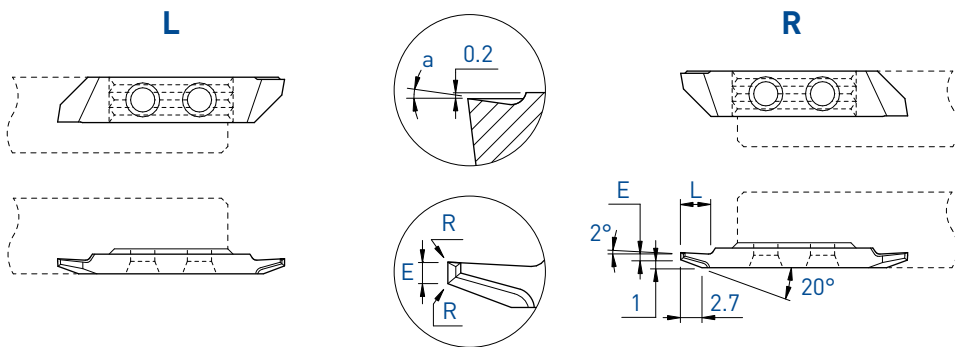

Pour un meilleur contrôle des copeaux  
Für eine bessere Spankontrolle  
For a better chip-control

**NEW**

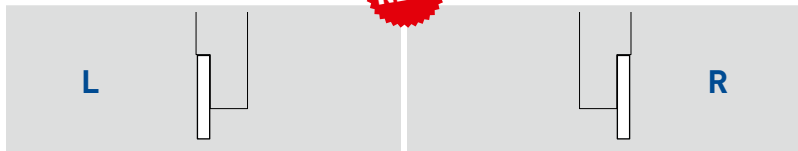

E	L	a	R	Art. N°	TiAlN	TiN	N (µk20)	HTA	HTiN	HN (µk10)	Art. N°	TiAlN	TiN	N (µk20)	HTA	HTiN	HN (µk10)
1.0	4	10°	0	733ZX10-1.0	■	□					743ZX10-1.0	■	□		■	□	
1.0	4	10°	0.08	733ZX10-1.0-R08	■	□					743ZX10-1.0-R08	■	□		□	□	

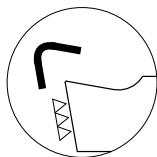

Arête de coupe honée  
Gehonte Schneidkante  
Honed edge

f min: 0.02 mm/U

7XX-XX-B



Sur demande pour serrage type B, voir page 1.03  
Wahlweise für B-Spannsystem, siehe Seite 1.03  
On request for B clamping system, see page 1.03

**Tourneur arrière pré-coupe**  
**Rückwärts drehen vorstechen**  
**Back turning pre-parting off**

**733P / 743P**

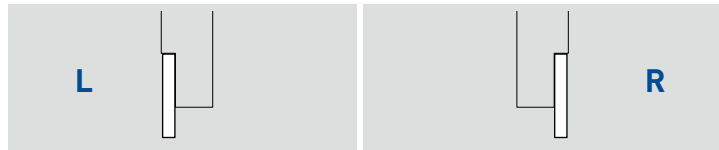
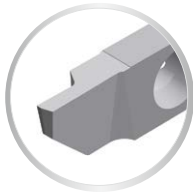
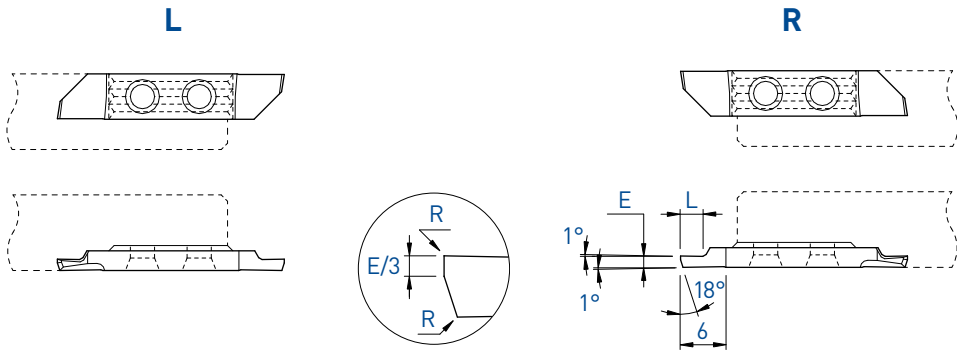

E	L	R	Art. N°	TiAlN			HTA			Art. N°	TiAlN			HTA		
				TiN	N (µk20)	N	HTiN	HN (µk10)	HN		TiN	N (µk20)	N	HTiN	HN (µk10)	HN
0.8	2	0	<b>733P-0.8</b>	■	■	■				<b>743P-0.8</b>	■	■	■	■	□	■
1.0	2	0	<b>733P-1.0</b>	■	■	■				<b>743P-1.0</b>	■	■	■	■		
1.2	2.5	0	<b>733P-1.2</b>	■	■	■				<b>743P-1.2</b>	■	■	■	■		
1.5	3	0	<b>733P-1.5</b>	■	■	■				<b>743P-1.5</b>	■	■	■	■		

**7XX-XX-B**



Sur demande pour serrage type B, voir page 1.03  
 Wahlweise für B-Spannsystem, siehe Seite 1.03  
 On request for B clamping system, see page 1.03

L

R

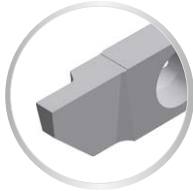
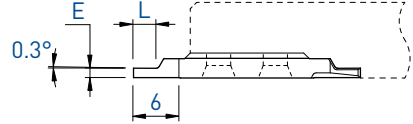
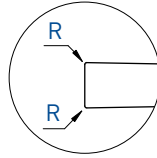
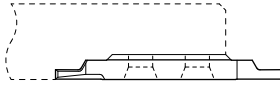
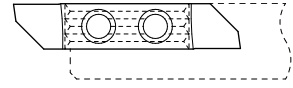
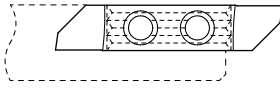

L



R



E	L	R	Art. N°	TiALN	TiN	N (µk20)	HTA	HTiN	HN (µk10)	Art. N°	TiALN	TiN	N (µk20)	HTA	HTiN	HN (µk10)
0.5	1.5	0	734-0.5	■	■	■	■	□	■	744-0.5	■	■	■	■	□	■
0.6	1.8	0	734-0.6	■	■	■	■	□	■	744-0.6	■	■	■	■	□	■
0.75	2	0	734-0.75	■	■	■	■			744-0.75	■	■	■	■		
0.8	2	0	734-0.8	■	■	■	■	□	■	744-0.8	■	■	■	■	□	■
0.8	2	0.08	-							744-0.8-R08	■	■	■	■	□	■
0.9	2.5	0	-							744-0.9	■	■	■	■	□	■
0.95	3	0	734-0.95	■	■	■				744-0.95	■	■	■			
1.0	2.5	0	734-1.0	■	■	■	■	■	■	744-1.0	■	■	■	■		
1.0	2.5	0.08	734-1.0-R08	■	■	■	■	■	■	744-1.0-R08	■	■	■	■	□	■
1.2	3	0	734-1.2	■	■	■	■	□	■	744-1.2	■	■	■	■		
1.5	3	0	734-1.5	■	■	■	■	■	■	744-1.5	■	■	■	■		
1.5	3	0.08	734-1.5-R08	■	■	■	■	□	■	744-1.5-R08	■	■	■	■	□	■
1.5	3	0.20	-							744-1.5-R20	■	■	■	■	□	■
1.8	4	0	734-1.8	■	■	■	■	□	■	744-1.8	■	■	■	■	□	■
2.0	4	0	734-2.0	■	■	■	■	□	■	744-2.0	■	■	■	■	□	■
2.0	4	0.08	734-2.0-R08	■	■	■	■	□	■	744-2.0-R08	■	■	■	■	□	■
2.0	4	0.20	-							744-2.0-R20	■	■	■	■	□	■
2.5	6	0	734-2.5	■	■	■				744-2.5	■	■	■	■	□	■

7XX-XX-B



Sur demande pour serrage type B, voir page 1.03  
Wahlweise für B-Spannsystem, siehe Seite 1.03  
On request for B clamping system, see page 1.03

Foncer-tourner

Einstecken und drehen

Grooving and turning

## 734VS / 744VS

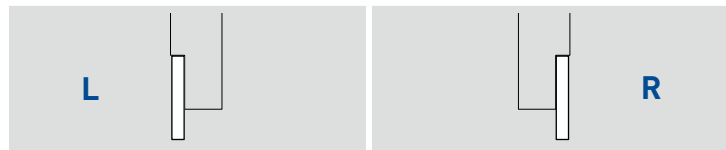
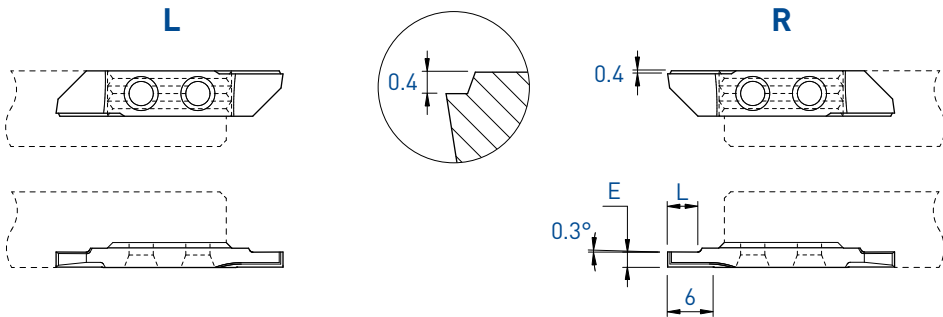

E	L	Art. N°	TiAlN			HTA		HN (µk10)	Art. N°	TiAlN			HTA		HN (µk10)
			TiN	TiN	N (µk20)	HTiN	HTiN			TiN	TiN	N (µk20)	HTiN	HTiN	
1.0	2	734VS-1.0	■	■	■	■	□	■	744VS-1.0	■	■	■	■	□	■
1.2	2.5	734VS-1.2	■	■	■	■	□	■	744VS-1.2	■	■	■	■	□	■
1.5	3	734VS-1.5	■	■	■				744VS-1.5	■	■	■	■	□	■
1.8	4	734VS-1.8	■	■	■				744VS-1.8	■	■	■			
2.0	4	734VS-2.0	■	■	■				744VS-2.0	■	■	■	■	□	■
2.5	6	734VS-2.5	■	■	■				744VS-2.5	■	■	■			

7XX-XX-B



Sur demande pour serrage type B, voir page 1.03  
Wahlweise für B-Spannsystem, siehe Seite 1.03  
On request for B clamping system, see page 1.03

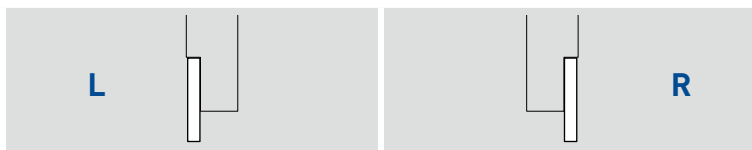
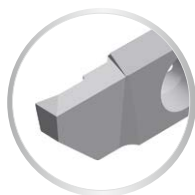
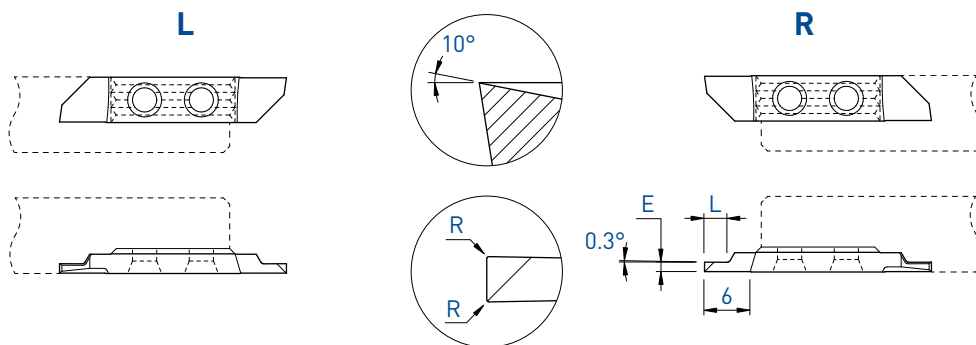

E	L	R	Art. N°	TiALN	TiN	N (µk20)	HTA	HTiN	HN (µk10)	Art. N°	TiALN	TiN	N (µk20)	HTA	HTiN	HN (µk10)
0.8	2	0	734X-0.8	■	■	■	■	□	■	744X-0.8	■	■	■	■	□	■
1.0	2.5	0	734X-1.0	■	■	■	■	□	■	744X-1.0	■	■	■	■	□	■
1.0	2.5	0.08	734X-1.0-R08	■	■	■	■	□	■	744X-1.0-R08	■	■	■	■	□	■
1.2	3	0	734X-1.2	■	■	■	■	□	■	744X-1.2	■	■	■	■	□	■
1.5	3	0	734X-1.5	■	■	■	■	■	■	744X-1.5	■	■	■	■	■	■
1.5	3	0.08	734X-1.5-R08	■	■	■	■	□	■	744X-1.5-R08	■	■	■	■	□	■
1.5	3	0.20	-							744X-1.5-R20	■	■	■	■	□	■
1.8	4	0	734X-1.8	■	■	■				744X-1.8	■	■	■		□	■
2.0	4	0	734X-2.0	■	■	■		□		744X-2.0	■	■	■		□	■
2.0	4	0.08	734X-2.0-R08	■	■	■		□		744X-2.0-R08	■	■	■		□	■
2.0	4	0.20	734X-2.0-R20	■	■	■		□		744X-2.0-R20	■	■	■		□	■
2.5	6	0	734X-2.5	■	■	■		□		744X-2.5	■	■	■		□	■

7XX-XX-B



Sur demande pour serrage type B, voir page 1.03  
Wahlweise für B-Spannsystem, siehe Seite 1.03  
On request for B clamping system, see page 1.03



Foncer-tourner

Einstecken und drehen

Grooving and turning

## 734ZX / 744ZX

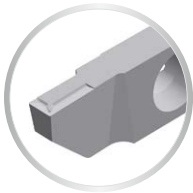
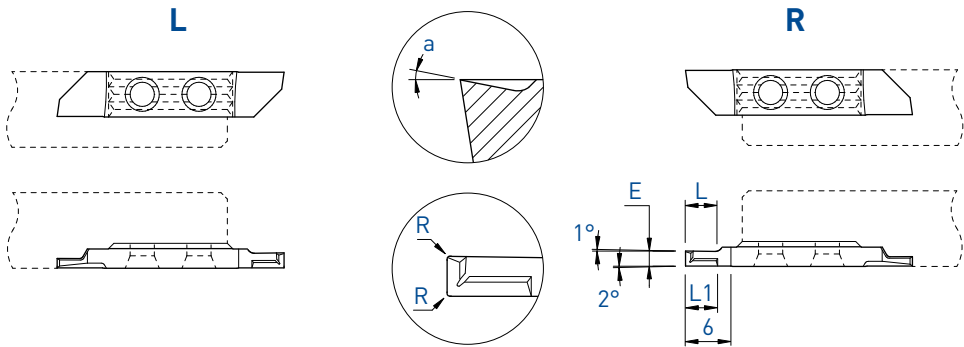

Pour un meilleur contrôle des copeaux  
Für eine bessere Spankontrolle  
For a better chip-control

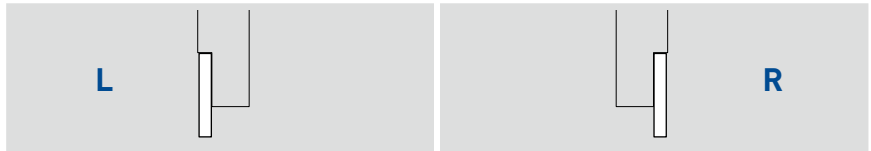

E	L	L1	a	R	Art. N°	TIALN	TiN	N (µk20)	HTA	HAS	HTiN	HN (µk10)	Art. N°	TIALN	TiN	N (µk20)	HTA	HAS	HTiN	HN (µk10)
1.0	2.5	3	10°	0.01	734ZX10-1.0	■	□						744ZX10-1.0	■	■		■		□	
1.5	4	4	10°	0.01	734ZX10-1.5	■	□						744ZX10-1.5	■	□		■		□	
1.5	4	4	10°	0.08	734ZX10-1.5-R08	■	■						744ZX10-1.5-R08	■	■					
2.0	4	4	10°	0.01	734ZX10-2.0	■	■						744ZX10-2.0	■	□		■		□	
2.0	4	4	10°	0.08	734ZX10-2.0-R08	■	■						744ZX10-2.0-R08	■	□					
2.5	6	4	10°	0.01	734ZX10-2.5	■	■						744ZX10-2.5	■	□		■		□	
2.5	6	4	10°	0.08	-								744ZX10-2.5-R08	■	□					
1.0	2.5	3	17°	0.01	-								744ZX17-1.0				■	■		

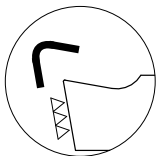

Arête de coupe honée  
Gehonte Schneidkante  
Honed edge

f min: 0.02 mm/U

7XX-XX-B



Sur demande pour serrage type B, voir page 1.03  
Wahlweise für B-Spannsystem, siehe Seite 1.03  
On request for B clamping system, see page 1.03

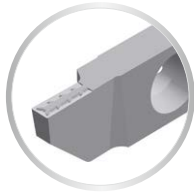
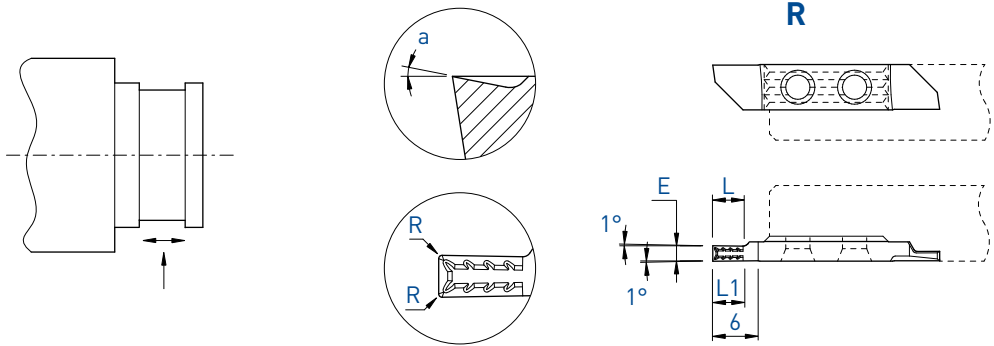

Pour un meilleur contrôle des copeaux  
Für eine bessere Spankontrolle  
For a better chip-control

**NEW**

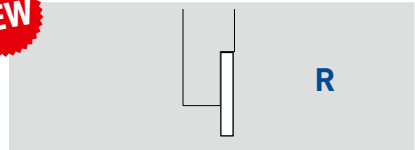

E	L	L1	a	R	Art. N°	TiAlN	TiN	N (µk20)	HTA	HTiN	HN (µk10)
1.0	6	2.5	10°	0.01	744ZXT10-1.0	■	■		■	□	
1.5	6	4	10°	0.01	744ZXT10-1.5	■	□		■	□	
1.5	6	4	10°	0.08	744ZXT10-1.5-R08	■	■		■	□	
2.0	6	4	10°	0.01	744ZXT10-2.0	■	□		■	□	
2.0	6	4	10°	0.08	744ZXT10-2.0-R08	■	□		■	□	
2.5	6	5	10°	0.01	744ZXT10-2.5	■	□		■	□	
2.5	6	5	10°	0.08	744ZXT10-2.5-R08	■	□		■	□	

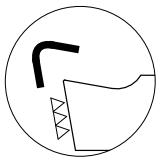

Arête de coupe honée  
Gehonte Schneidkante  
Honed edge

f min: 0.02 mm/U

7XX-XX-B



Sur demande pour serrage type B, voir page 1.03  
Wahlweise für B-Spannsystem, siehe Seite 1.03  
On request for B clamping system, see page 1.03

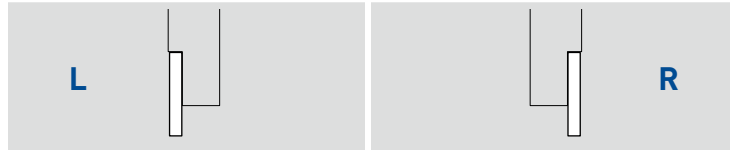
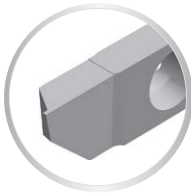
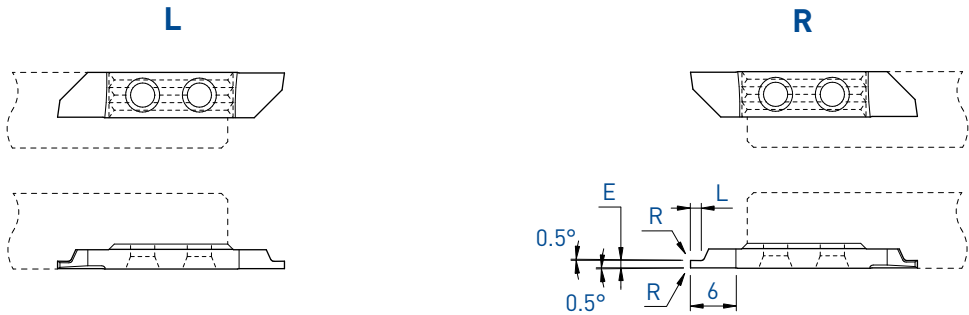

E ± 0.01			Art. N°	TiAlN	TiN	N (µk20)	HTA	HTiN	HN (µk10)	Art. N°	TiAlN	TiN	N (µk20)	HTA	HTiN	HN (µk10)
	L	R		■	■	■	■	■	■		■	■	■	■	■	■
0.2	0.2	0	735-0202	■	■	■				745-0202	■	■	■	■	□	■
0.3	0.3	0	735-0303	■	■	■				745-0303	■	■	■	■	□	■
0.4	0.4	0	735-0404	■	■	■	■	□	■	745-0404	■	□	■	■	■	■

Voir également TRIO-Line, page 2.05  
 Siehe auch TRIO-Line, Seite 2.05  
 See also TRIO-Line, page 2.05

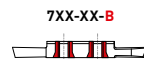

Sur demande pour serrage type B, voir page 1.03  
 Wahlweise für B-Spannsystem, siehe Seite 1.03  
 On request for B clamping system, see page 1.03

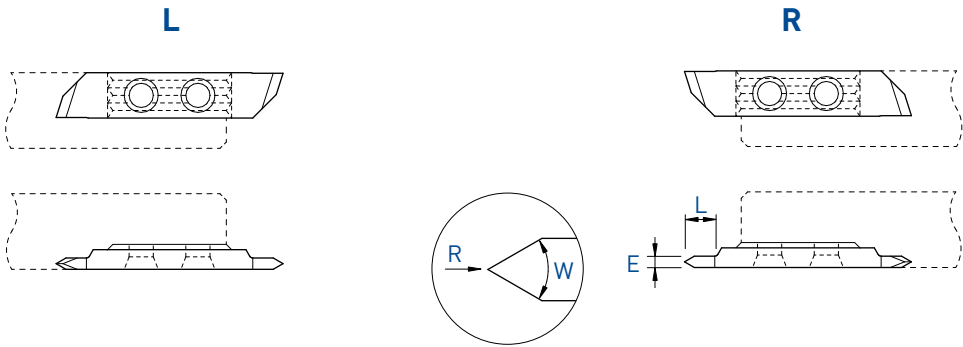

Profil partiel  
Teilprofil  
Partial profile

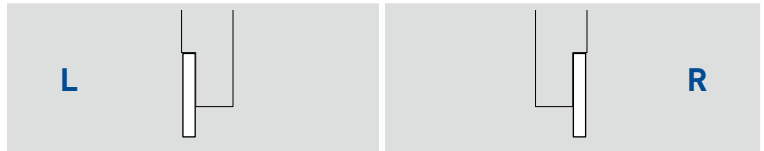

W	E	L	R	Art. N°	L			R									
					TiAlN	TiN	N [µk20]	HTA	HTiN	HN [µk10]	Art. N°	TiAlN	TiN	N [µk20]	HTA	HTiN	HN [µk10]
60°	1.5	4	0	736-60-1.5	■	■	■				746-60-1.5	■	■	■			
60°	1.5	4	0.02	736-60-1.5-R02	■	■	■	■	■	■	746-60-1.5-R02	■	■	■	■	□	■
60°	2.0	6	0	736-60-2	■	■	■				746-60-2	■	■	■			
60°	2.0	6	0.02	736-60-2-R02	■	■	■	■	■	■	746-60-2-R02	■	■	■	■	■	■
55°	1.5	4	0	736-55-1.5	■	■	■				746-55-1.5	■	■	■			
55°	2.0	6	0	736-55-2	■	■	■				746-55-2	■	■	■			

7XX-XX-B



Sur demande pour serrage type B, voir page 1.03  
Wahlweise für B-Spannsystem, siehe Seite 1.03  
On request for B clamping system, see page 1.03

**Fileter**

**Gewinde drehen**

**Threading**

**736-A60° / 746-A60°**

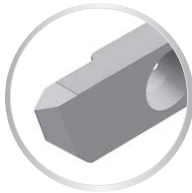
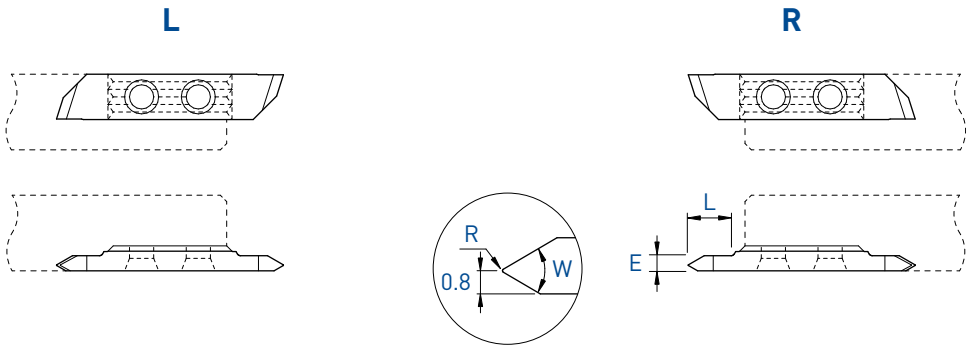

Profil partiel  
Teilprofil  
Partial profile

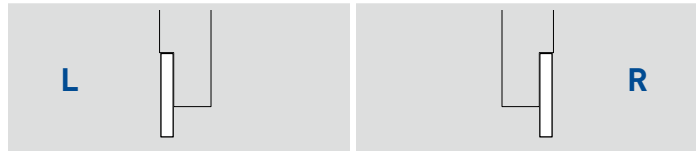

W	E	L	R	Pas steigung Pitch P	Art. N°	TiALN	TiN	N (µk20)	HTA	HTiN	HN (µk10)	Art. N°	TiALN	TiN	N (µk20)	HTA	HTiN	HN (µk10)
60°	2.0	6	0.06	0.50-1.50	<b>736-A60°</b>	■	■	■	□	□	□	<b>746-A60°</b>	■	■	■	■	□	■

Plaquettes à fileter avec coupe positive 2°, voir page 1.124  
WSP Gewindedrehen mit positivem Schnitt 2°, siehe Seite 1.124  
Threading insert with positive cut 2°, see page 1.124



Sur demande pour serrage type B, voir page 1.03  
Wahlweise für B-Spannsystem, siehe Seite 1.03  
On request for B clamping system, see page 1.03

■ = disponible / verfügbar / available  
□ = selon disponibilité du stock / jenach Lagerverfügbarkeit / depending on stock availability

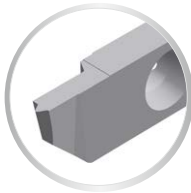
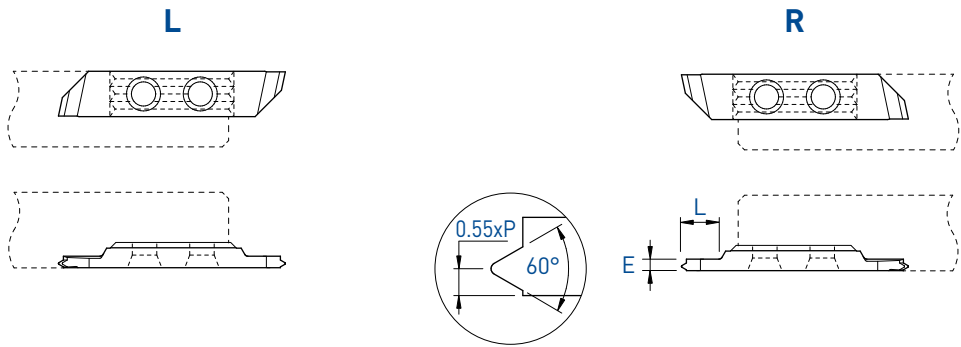

Profil complet métrique  
Vollprofil metrisch  
Full profile metric

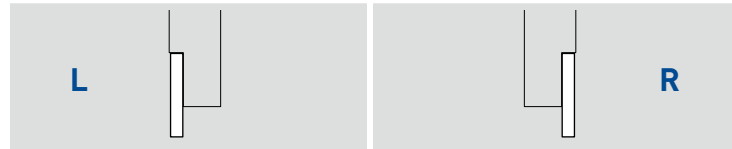

Pas steigung Pitch P	E	L	Art. N°	L			R								
				TiAlN	TiN	N (µk20)	HTA	HTiN	HN (µk10)	Art. N°	TiAlN	TiN	N (µk20)	HTA	HTiN
0.25	1.0	3	736-M-0.25	■	■	■			746-M-0.25	■	■	■			
0.30	1.0	3	736-M-0.30	■	■	■			746-M-0.30	■	■	■			
0.35	1.0	3	736-M-0.35	■	■	■			746-M-0.35	■	■	■			
0.40	1.0	3	736-M-0.40	■	■	■			746-M-0.40	■	■	■			
0.45	1.0	3	736-M-0.45	■	■	■			746-M-0.45	■	■	■			
0.50	1.0	3	736-M-0.50	■	■	■			746-M-0.50	■	■	■			
0.60	1.0	3	736-M-0.60	■	■	■			746-M-0.60	■	■	■			
0.70	1.0	3	736-M-0.70	■	■	■			746-M-0.70	■	■	■			
0.75	1.0	3	736-M-0.75	■	■	■			746-M-0.75	■	■	■			
0.80	1.5	4.5	736-M-0.80	■	■	■			746-M-0.80	■	■	■			
1.00	1.5	4.5	736-M-1.00	■	■	■			746-M-1.00	■	■	■			
1.25	1.5	4.5	736-M-1.25	■	■	■			746-M-1.25	■	■	■			
1.50	2.0	6	736-M-1.50	■	■	■			746-M-1.50	■	■	■			
1.75	2.0	6	736-M-1.75	■	■	■			746-M-1.75	■	■	■			

Plaquettes à fileter avec coupe positive 2°, voir page 1.125  
WSP Gewindedrehen mit positivem Schnitt 2°, siehe Seite 1.125  
Threading insert with positive cut 2°, see page 1.125



Sur demande pour serrage type B, voir page 1.03  
Wahlweise für B-Spannsystem, siehe Seite 1.03  
On request for B clamping system, see page 1.03

Plaquette à rayon  
 Radius-Wendeplatte  
 Insert with radius

737 / 747

L

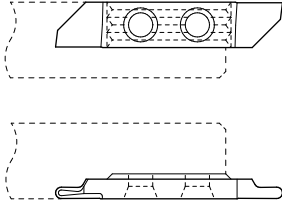

R

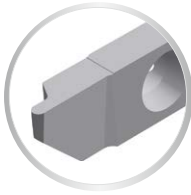
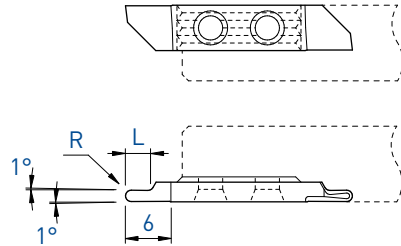

L

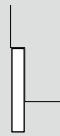

R



R	L	Art. N°	L			R									
			TiAlN	TiN	N (µk20)	HTA	HTiN	HN (µk10)	Art. N°	TiAlN	TiN	N (µk20)	HTA	HTiN	HN (µk10)
0.25	1.5	-						747-R0.25	■	■	■				
0.40	2	-						747-R0.4	■	■	■				
0.5	2.5	737-R0.5	■	■	■			747-R0.5	■	■	■				
0.6	2.5	737-R0.6	■	■	■			747-R0.6	■	■	■				
0.75	3	737-R0.75	■	■	■			747-R0.75	■	■	■				
0.8	3	737-R0.8	■	■	■			747-R0.8	■	■	■				
1.0	4	737-R1.0	■	■	■			747-R1.0	■	■	■				

7XX-XX-B



Sur demande pour serrage type B, voir page 1.03  
 Wahlweise für B-Spannsystem, siehe Seite 1.03  
 On request for B clamping system, see page 1.03

Plaquette ébauche

WSP-Rohling

Blank insert

**731-E / 741-E**  
**731-EP / 741-EP**

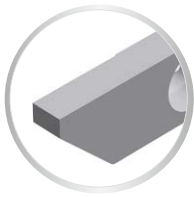

**L**

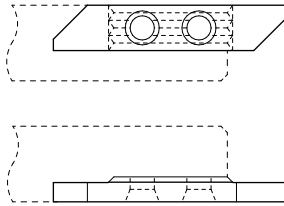

**R**

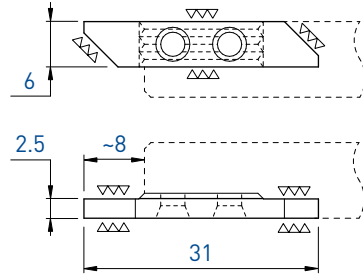

<b>L</b>		<b>R</b>			
Art. N°	N (µk20)	HN (µk10)	Art. N°	N (µk20)	HN (µk10)
731-E	■	■	741-E	■	■



Face de coupe polie  
Polierte Schneidfläche  
Cutting face polished

**L**

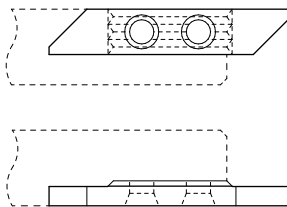

**R**

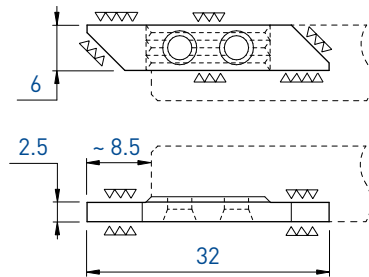

<b>L</b>		<b>R</b>											
Art. N°	TiALN	TiN	N (µk20)	HTA	HTiN	HN (µk10)	Art. N°	TiALN	TiN	N (µk20)	HTA	HTiN	HN (µk10)
731-EP	■	■	■	■	■	■	741-EP	■	■	■	■	□	■

7XX-XX-B



Sur demande pour serrage type B,  
voir page 1.03  
Wahlweise für B-Spannsystem,  
siehe Seite 1.03  
On request for B clamping system,  
see page 1.03



**OUTILS DE HAUTES PERFORMANCES  
POUR LE DÉCOLLETAGE  
ET LA MICROMÉCANIQUE**

**HOCHLEISTUNGSWERKZEUGE  
FÜR DREHAUTOMATEN  
UND MIKROMECHANIK**

**HIGH PERFORMANCE TOOLING  
FOR AUTOMATIC LATHES  
AND MICROMECHANICS**

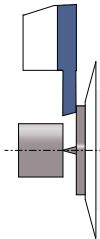
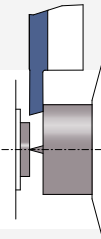
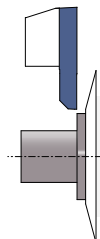
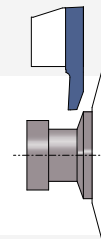
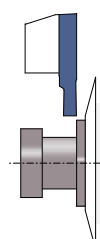
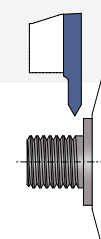
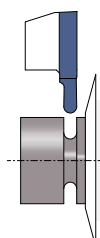

L			R		
Type		Page	Type		Page
<b>750</b>	750	1.78	<b>760</b>	760	1.78
	750-JET	1.82		760/750	1.78
	750RC	1.79		760/750-D	1.81
<b>751</b>	751	1.84	760-JET	1.82	
	751-E	1.128	760LC	1.80	
	751-EP	1.128	760-NOVIBRA	1.83	
	751NXF	1.92/1.101	<b>761</b>	761	1.84
	751R	1.93	761-E	1.128	
	751-R05	1.86	761-EP	1.128	
	751RAS	1.103	761L	1.93	
	751RD	1.102	761LD	1.102	
	751R-R05	1.95	761L-R05	1.95	
	751RS	1.94	761LS	1.94	
	751RU	1.100	761LX12	1.98	
	751RX12	1.98	761LX25	1.99	
	751RX25	1.99	761LX4	1.96	
	751RX4	1.96	761LXF	1.97	
	751RXF	1.97	761NXF	1.92/101	
	751S	1.85	761-R05	1.86	
	751U	1.91	761S	1.85	
	751X12	1.89	761U	1.91	
	751X25	1.90	761X12	1.89	
	751X4	1.87	761X25	1.90	
751XF	1.88	761X4	1.87		
<b>752</b>	752	1.104	761XF	1.88	
	752PX	1.105	<b>762</b>	762	1.104
	752S05	1.108	762PX	1.105	
<b>753</b>	752X	1.106	762S05	1.108	
	753	1.109	762X	1.106	
	753P	1.117	762ZX	1.107	
<b>753</b>	753S05	1.108	<b>763</b>	763	1.109
	753VX-15°	1.115	763P	1.117	
	753VX-8°	1.112	763S05	1.108	
	753VX-805	1.113	763VX-15°	1.115	
	753X	1.110	763VX-8°	1.112	
	753XS	1.111	763VX-800	1.114	
	753ZX10	1.116	763VX-805	1.113	
	<b>754</b>	754	1.118	763X	1.110
		754VS	1.119	763XS	1.111
		754X	1.120	763ZX10	1.116
754ZX10		1.121	<b>764</b>	764	1.118
754ZXT		1.122	764VS	1.119	
<b>756</b>	756-55	1.123	764X	1.120	
	756-60	1.123	764ZX10	1.121	
	756-AG60°	1.124	764ZX25	1.121	
	756-G60°	1.124	764ZXT	1.122	
	756-M	1.125	<b>766</b>	766-55	1.123
<b>757</b>	757	1.126	766-60	1.123	
	757ZX	1.127	766-AG60°	1.124	
			766-G60°	1.124	
		766-M	1.125		
		<b>767</b>	767	1.126	
			767ZX	1.127	

			<b>750 / 760</b> Porte-outils Halter Holders	> 1.78
	<b>751 / 761</b> Tronçonnage Abstechen Parting off			> 1.84
			<b>761L / 751R</b> Tronçonnage - coupe déportée Abstechen - versetztes Schneiden Parting off - cut off line	> 1.93
	<b>752 / 762</b> Tourneur avant Vorwärts drehen Front turning			> 1.104
			<b>753 / 763</b> Tourneur arrière Rückwärts drehen Back turning	> 1.108
	<b>754 / 764</b> Foncer-tourner Einstechen und drehen Grooving and turning			> 1.118
			<b>756 / 766</b> Fileter Gewinde drehen Threading	> 1.123
	<b>757 / 767</b> Plaquettes à rayon Radius Wendplatten Inserts with radius			> 1.126
			Plaquette ébauche WSP-Rohling Blank insert	> 1.128

L

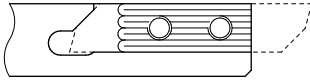

R

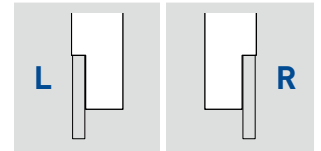
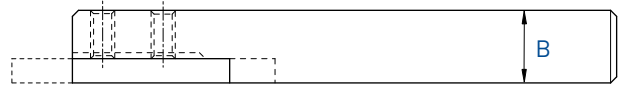
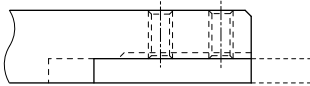
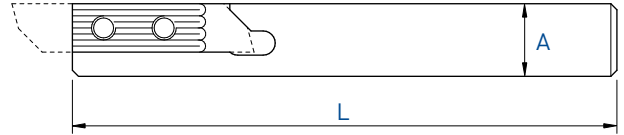

Serrage standard A  
Standard Spannsystem A  
Standard clamping system A

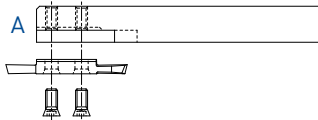

A x B	L	Serrage Spannsystem Clamping	Art. N°	Art. N°
10 x 10	115	A	750-10	760-10
10 x 10	115	A + B	750-10-AB	760-10-AB
10 x 10	50	A	750-10-50	760-10-50
12 x 12	130	A	750-12	760-12
12 x 12	130	A + B	750-12-AB	760-12-AB
12 x 12	90	A	750-12-90	760-12-90
12 x 12	90	A + B	750-12-90-AB	760-12-90-AB
12.7 x 12.7	130	A + B	750-12.7	760-12.7
14 x 14	130	A + B	750-14	760-14
16 x 16	130	A + B	750-16	760-16
16 x 16	75	A + B	750-16-75	760-16-75
20 x 20	120	A + B	750-20	760-20
25 x 25	140	A	760/750-25	

Serrage A + B  
Spannsystem A + B  
Clamping system A + B

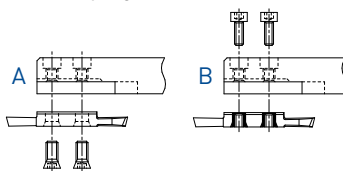

760/750-25  
R + L



Chaque support est livré avec vis et clé.  
Jeder Halter wird mit Spannschraube(n) und Schlüssel geliefert.  
Screw(s) and key are included with each tool holder.

Porte-outils

Coupe à droite déportée

Halter

Versetztes Rechtsschneiden

Holder

Right cut off line

## 750RC

Utiliser des plaquettes type 751R  
WSP Typ 751R verwenden  
Use inserts type 751R

Voir pages 1.93 - 1.103  
Siehe Seiten 1.93 - 1.103  
See pages 1.93 - 1.103

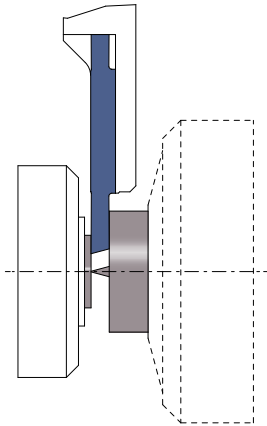
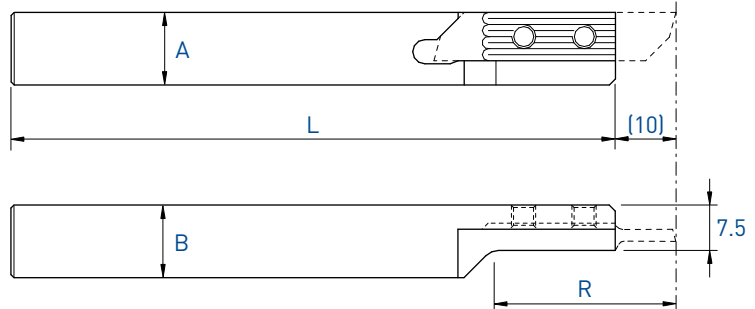

### L (R)

Coupe à droite déportée  
Versetztes Rechtsschneiden  
Right cut off line

A x B	R	L	Art. N°
12 x 12	30	130	<b>750RC-12</b>
16 x 16	40	130	<b>750RC-16</b>

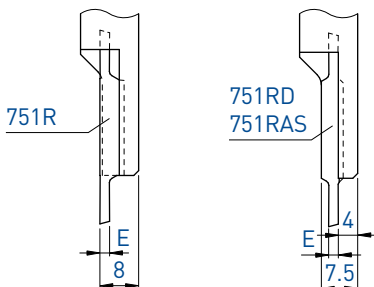

Chaque support est livré avec vis et clé.  
Jeder Halter wird mit Spannschraube(n) und Schlüssel geliefert.  
Screw(s) and key are included with each tool holder.

Porte-outils

Halter

Holder

Coupe à gauche déportée

Versetztes Linksschneiden

Left cut off line

760LC

Utiliser des plaquettes type 761L  
WSP Typ 761L verwenden  
Use insets type 761L

Voir pages 1.93 - 1.102  
Siehe Seiten 1.93 - 1.102  
See pages 1.93 - 1.102

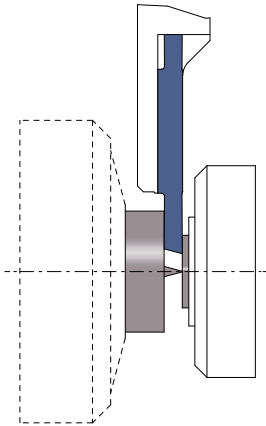
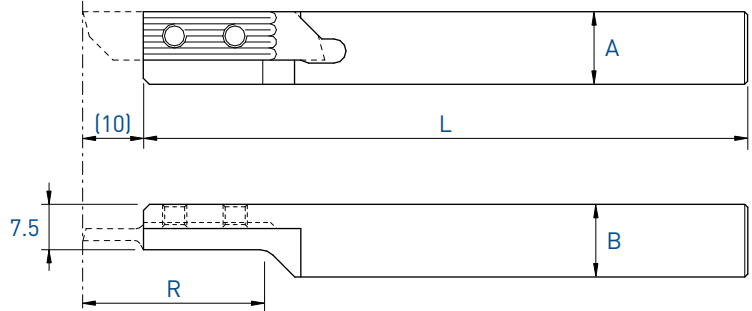

**R (L)**

Coupe à gauche déportée  
Versetztes Linksschneiden  
Left cut off line

A x B	R	L	Art. N°
16 x 16	40	130	760LC-16

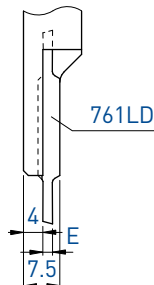
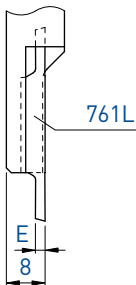

Chaque support est livré avec vis et clé.  
Jeder Halter wird mit Spanschraub(e)n und Schlüssel geliefert.  
Screw(s) and key are included with each tool holder.

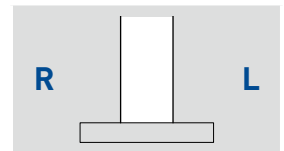
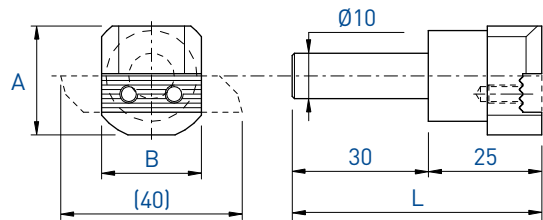
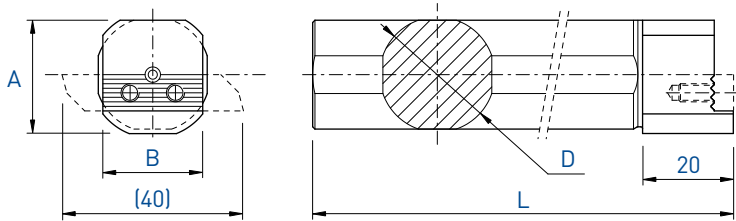

D	L	A	B	Art. N°
10	55	24	22	<b>760/750-D10</b>
16	160	25	22	<b>760/750-D16</b>
19.05	160	25	22	<b>760/750-D19.05</b>
19.05	110	25	22	<b>760/750-D19.05-S</b>
20	160	25	22	<b>760/750-D20</b>
22	110	25	22	<b>760/750-D22</b>
25	200	25	22	<b>760/750-D25</b>
25.4	200	25	22	<b>760/750-D25.4</b>
25.4	125	25	22	<b>760/750-D25.4-S</b>

Chaque support est livré avec vis et clé.  
 Jeder Halter wird mit Spannschraub(e)n und Schlüssel geliefert.  
 Screw(s) and key are included with each tool holder.

# TOP-Line

Porte-outils avec arrosage intégré

Halter mit integriertem Kühlmittelzufuhr

Holder with integrated coolant supply

## 750-JET / 760-JET

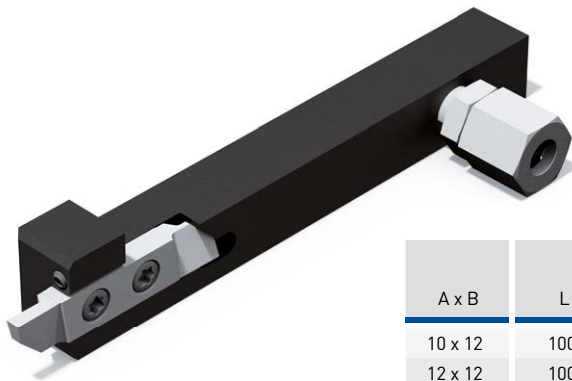
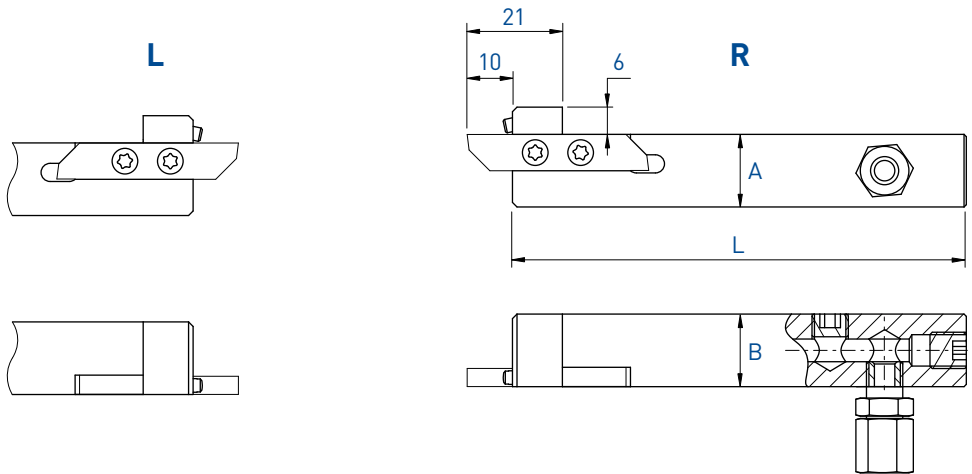

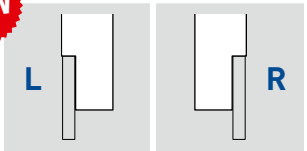

**NEW**



A x B	L	Serrage Spannsystem Clamping	Art. N°	Art. N°
10 x 12	100	A + B	750-1012-JET	760-1012-JET
12 x 12	100	A + B	750-12-JET	760-12-JET
12.7 x 12.7	100	A + B	750-12.7-JET	760-12.7-JET
16 x 16	100	A + B	750-16-JET	760-16-JET
20 x 20	100	A + B	750-20-JET	760-20-JET

Chaque support est livré avec vis et clé.  
Jeder Halter wird mit Spannschraube(n) und Schlüssel geliefert.  
Screw(s) and key are included with each tool holder.

Pièces de rechange Ersatzteile Spare parts			Buse Düse Nozzle 
	Art. N°	Art. N°	Art. N°
750-JET / 760-JET	J-M8X1-D6	JB-M8X1	JJ-M3X6-D1.5



Porte-outils en métal lourd anti-vibratoire  
 Schwingungsdämpfende Schwermetallhalter  
 Low vibration heavy metal holders

## 760-NOVIBRA

R

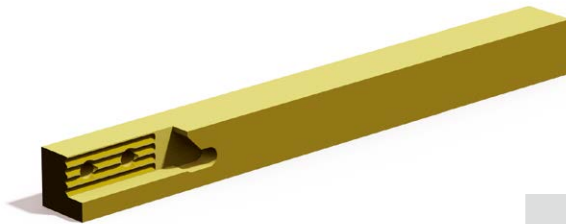
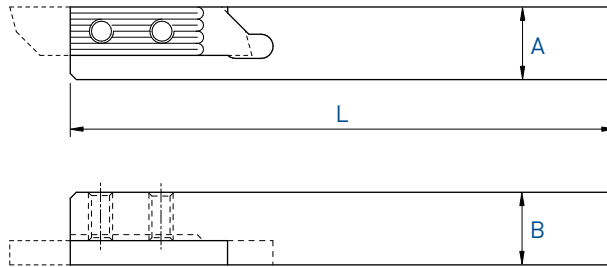

**NEW**

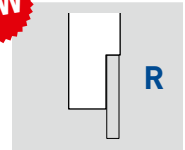

A x B	L	Serrage Spannsystem Clamping	Art. N°
10 x 10	115	A	<b>760-10-NOVIBRA</b>
12 x 12	130	A	<b>760-12-NOVIBRA</b>

Chaque support est livré avec vis et clé.  
 Jeder Halter wird mit Spannschraube(n) und Schlüssel geliefert.  
 Screw(s) and key are included with each tool holder.

L

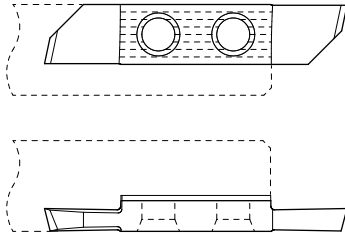

R

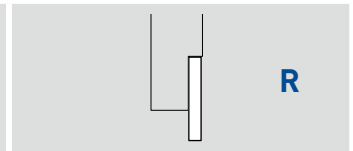
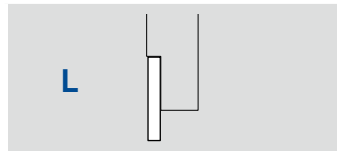
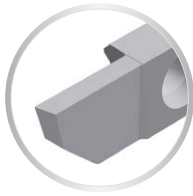
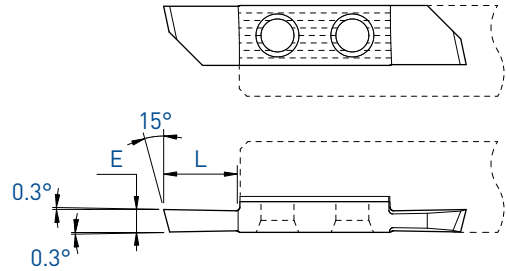

E	L	Art. N°	L			R									
			TiALN	TiN	N (µk20)	HTA	HTiN	HN (µk10)	Art. N°	TiALN	TiN	N (µk20)	HTA	HTiN	HN (µk10)
1.0	5	751-1.0	■	■	■	■	□	■	761-1.0	■	■	■	■	■	■
1.2	5	751-1.2	■	■	■				761-1.2	■	■	■	■	□	■
1.5	7.5	751-1.5	■	■	■	■	□	■	761-1.5	■	■	■	■	■	■
1.8	7.5	751-1.8	■	■	■				761-1.8	■	■	■	■	□	■
2.0	10	751-2.0	■	■	■	■	□	■	761-2.0	■	■	■	■	■	■
2.2	10	751-2.2	■	■	■				761-2.2	■	■	■	■	□	■
2.5	10	751-2.5	■	■	■	■	□	■	761-2.5	■	■	■	■	■	■
3.0	10	751-3.0	■	■	■				761-3.0	■	■	■	■	□	■

7XX-XX-B



Sur demande pour serrage type B, voir page 1.03  
Wahlweise für B-Spannsystem, siehe Seite 1.03  
On request for B clamping system, see page 1.03

Tronçonnage

Abstechen

Parting off

## 751S / 761S

L

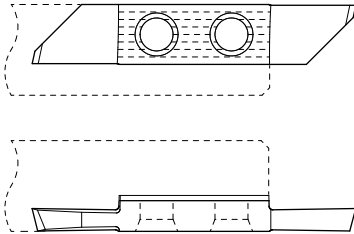

R

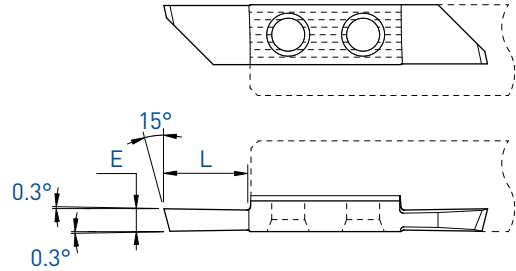

L



R



E	L	Art. N°	TiALN	TiN	N (µk20)	HTA	HTiN	HN (µk10)	Art. N°	TiALN	TiN	N (µk20)	HTA	HTiN	HN (µk10)
2.0	11.5	751S-2.0	■	■	■	■	□	■	761S-2.0	■	■	■	■	□	■
2.2	11.5	751S-2.2	■	■	■				761S-2.2	■	■	■	■	□	■
2.5	11.5	751S-2.5	■	■	■	■	□	■	761S-2.5	■	■	■	■	□	■
3.0	11.5	751S-3.0	■	■	■				761S-3.0	■	■	■	■	□	■

7XX-XX-B



Sur demande pour serrage type B, voir page 1.03  
Wahlweise für B-Spannsystem, siehe Seite 1.03  
On request for B clamping system, see page 1.03

Tronçonnage

Abstechen

Parting off

## 751-R05 / 761-R05

L

R

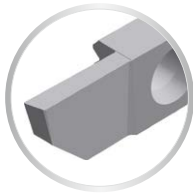
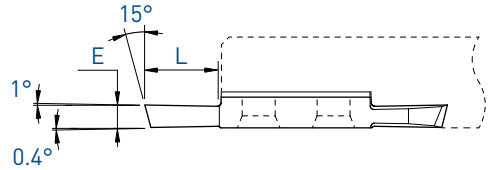
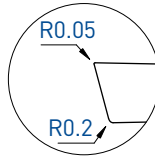
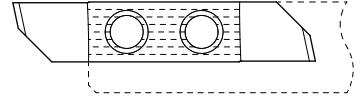
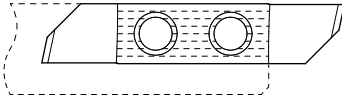

L

R

E	L	Art. N°	L			R			HTA	HTiN	HN [µk10]
			TiALN	TiN	N [µk20]	TiALN	TiN	N [µk20]			
1.5	7.5	751-1.5-R05	■	■	■	■	■	■	■	■	■
2.0	10	751-2.0-R05	■	■	■	■	■	■	■	■	■
2.5	10	751-2.5-R05	■	■	■	■	■	■	■	■	■

7XX-XX-B



Sur demande pour serrage type B, voir page 1.03  
Wahlweise für B-Spannsystem, siehe Seite 1.03  
On request for B clamping system, see page 1.03

Tronçonnage

Abstechen

Parting off

## 751X4 / 761X4

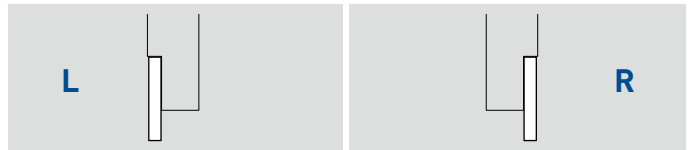
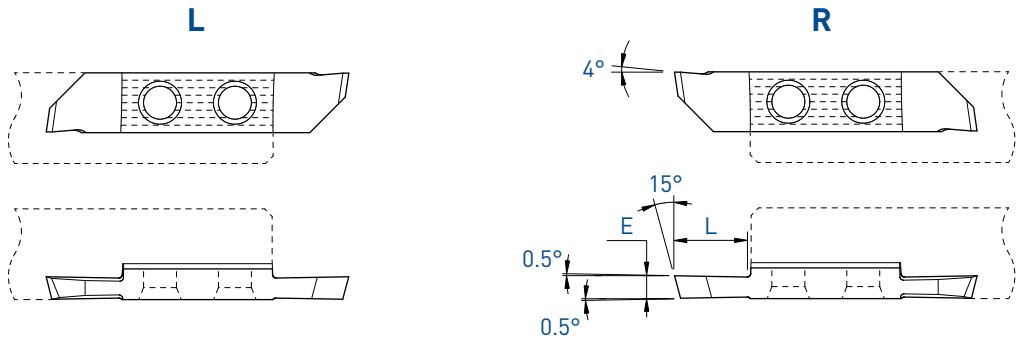

E	L	Art. N°	L			R		
			TiALN	TiN	N (µk20)	HTA	HTiN	HN (µk10)
1.5	7.5	-	■	■	■	■	□	■
2.0	10	751X4-2.0	■	■	■	■	□	■
2.5	10	-	■	■	■	■	■	■

7XX-XX-B



Sur demande pour serrage type B, voir page 1.03  
Wahlweise für B-Spannsystem, siehe Seite 1.03  
On request for B clamping system, see page 1.03

# TOP-Line

Tronçonnage

Abstechen

Parting off

## 751XF / 761XF

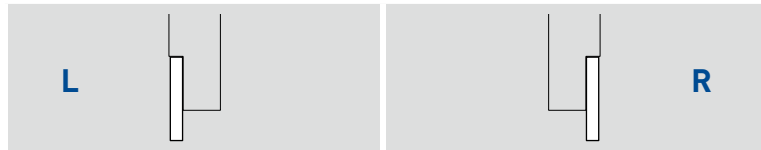
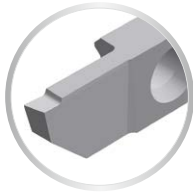
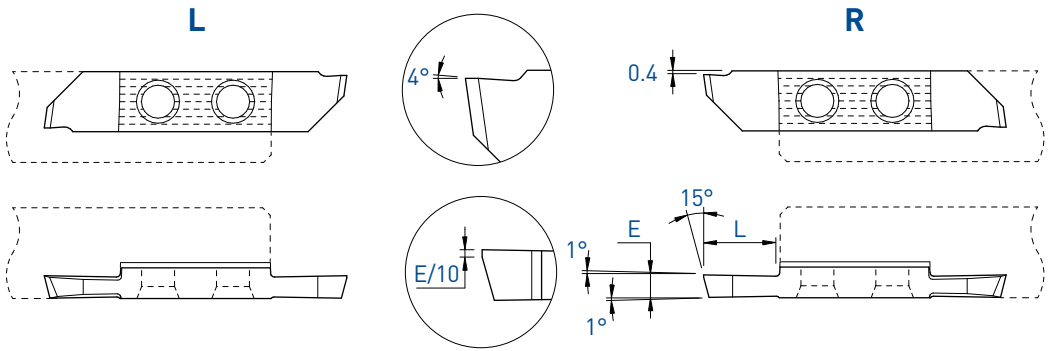

E	L	Art. N°	L			R									
			TiALN	TiN	N (µk20)	HTA	HTiN	HN (µk10)	Art. N°	TiALN	TiN	N (µk20)	HTA	HTiN	HN (µk10)
1.5	7.5	751XF-1.5	■	■	■	■	□	■	761XF-1.5	■	■	■	■	□	■
2.0	10	751XF-2.0	■	■	■	■	■	■	761XF-2.0	■	■	■	■	■	■
2.2	10	751XF-2.2	■	■	■				761XF-2.2	■	■	■			
2.5	10	751XF-2.5	■	■	■	■	□	■	761XF-2.5	■	■	■			
3.0	10	751XF-3.0	■	■	■				761XF-3.0	■	■	■	■	□	■

7XX-XX-B



Sur demande pour serrage type B, voir page 1.03  
Wahlweise für B-Spannsystem, siehe Seite 1.03  
On request for B clamping system, see page 1.03

Tronçonnage

Abstechen

Parting off

## 751X12 / 761X12

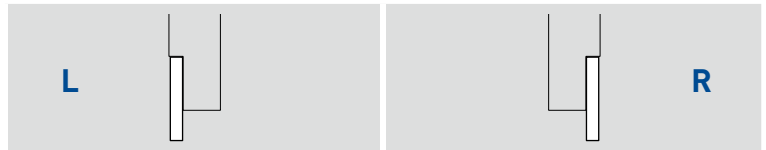
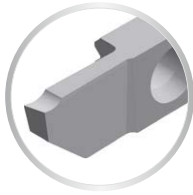
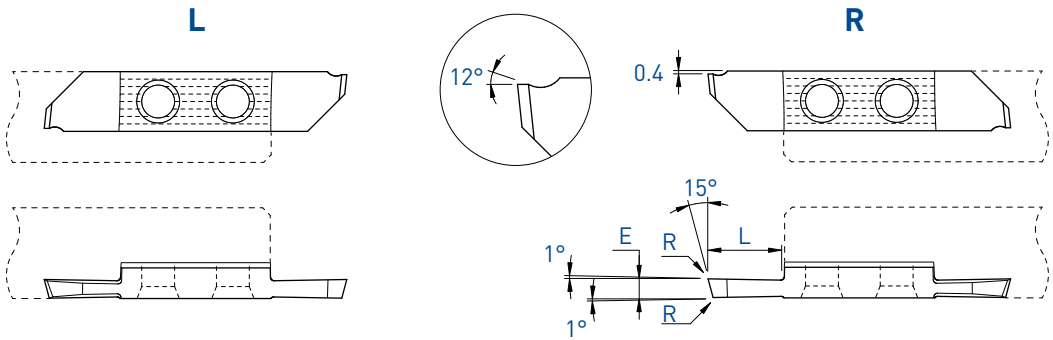

E	L	R	Art. N°	TiALN	TiN	N (µk20)	HTA	HTiN	HN (µk10)	Art. N°	TiALN	TiN	N (µk20)	HTA	HTiN	HN (µk10)
1.5	7.5	0.03	751X12-1.5	■	■	■	■	□	■	761X12-1.5	■	■	■			
2.0	10	0.03	751X12-2.0	■	■	■	■	□	■	761X12-2.0	■	■	■	■	□	■
2.5	10	0.03	751X12-2.5	■	■	■				761X12-2.5	■	■	■	■	□	■

7XX-XX-B



Sur demande pour serrage type B, voir page 1.03  
Wahlweise für B-Spannsystem, siehe Seite 1.03  
On request for B clamping system, see page 1.03

# TOP-Line

Tronçonnage

Abstechen

Parting off

751X25 / 761X25

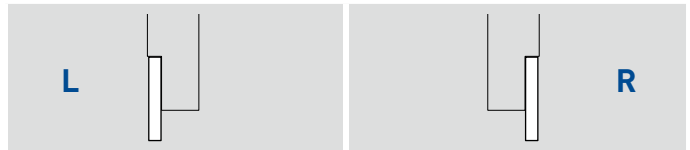
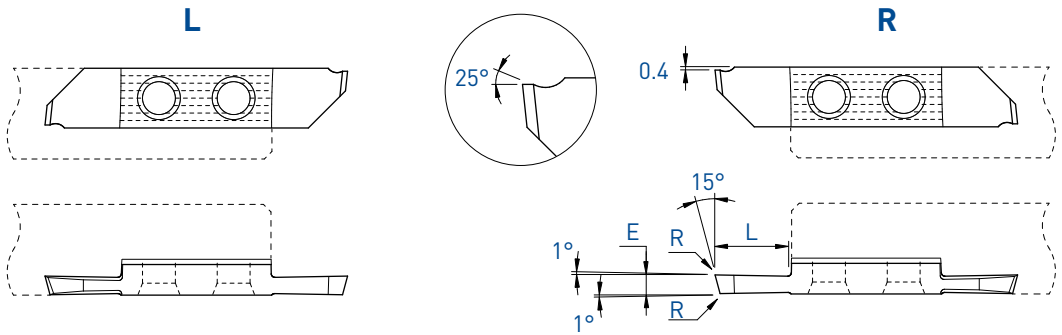

E	L	R	Art. N°	TiALN	TiN	N (µk20)	HTA	HTiN	HN (µk10)	Art. N°	TiALN	TiN	N (µk20)	HTA	HTiN	HN (µk10)
1.5	7.5	0.03	751X25-1.5	■	■	■				761X25-1.5	■	■	■			
2.0	10	0.03	751X25-2.0	■	■	■				761X25-2.0	■	■	■			
2.5	10	0.03	751X25-2.5	■	■	■				761X25-2.5	■	■	■	■	□	■

7XX-XX-B



Sur demande pour serrage type B, voir page 1.03  
Wahlweise für B-Spannsystem, siehe Seite 1.03  
On request for B clamping system, see page 1.03



Tronçonnage

Abstechen

Parting off

## 751U / 761U

L

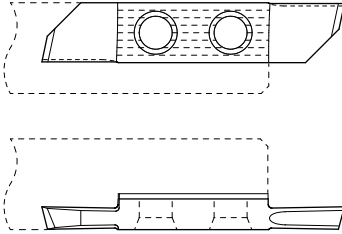

R

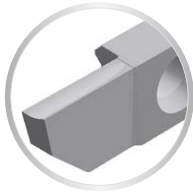
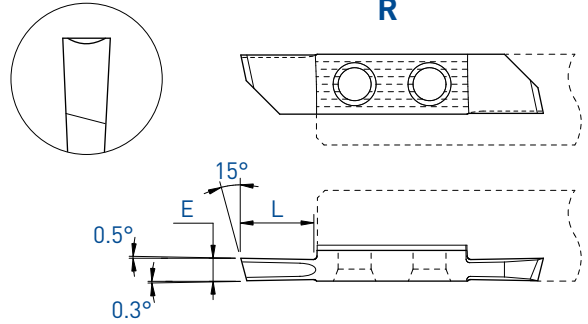

L



R



E	L	Art. N°	TiALN	TiN	N (µk20)	HTA	HTiN	HN (µk10)	Art. N°	TiALN	TiN	N (µk20)	HTA	HTiN	HN (µk10)
2.0	10	751U-2.0	■	■	■				761U-2.0	■	■	■	■	□	■

7XX-XX-B



Sur demande pour serrage type B, voir page 1.03  
Wahlweise für B-Spannsystem, siehe Seite 1.03  
On request for B clamping system, see page 1.03

Tronçonnage

Abstechen

Parting off

## 751NXF / 761NXF

L

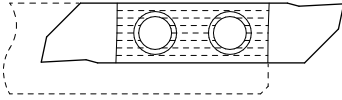

R

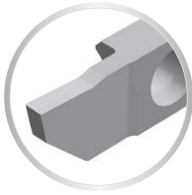
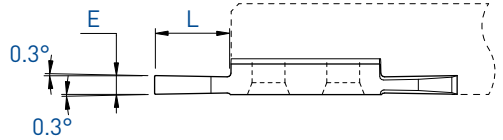
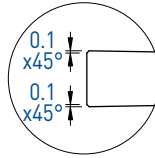
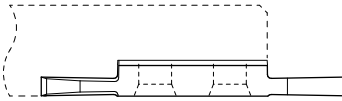
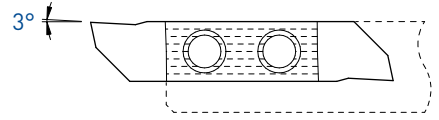

L

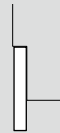

R



E	L	Art. N°	L			R									
			TiALN	TiN	N (µk20)	HTA	HTiN	HN (µk10)	Art. N°	TiALN	TiN	N (µk20)	HTA	HTiN	HN (µk10)
2.0	10	751NXF-2.0	■	■	■	■	□	■	761NXF-2.0	■	■	■	■	□	■
2.5	10	751NXF-2.5	■	■	■				761NXF-2.5	■	■	■			
3.0	10	751NXF-3.0	■	■	■				761NXF-3.0	■	■	■			

7XX-XX-B



Sur demande pour serrage type B, voir page 1.03  
Wahlweise für B-Spannsystem, siehe Seite 1.03  
On request for B clamping system, see page 1.03

Tronçonnage

Coupe déportée

Abstechen

Versetztes Schneiden

Parting off

Cut off line

## 761L / 751R

### Cut L

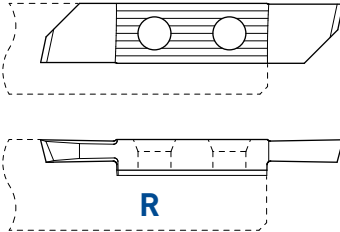

### Cut R

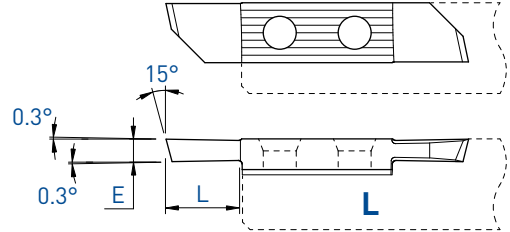

### R (L)

Coupe à gauche déportée  
Versetztes Linksschneiden  
Left cut off line

### L (R)

Coupe à droite déportée  
Versetztes Rechtsschneiden  
Right cut off line

E	L	Art. N°	TiALN	TiN	N (µk20)	HTA	HTiN	HN (µk10)	Art. N°	TiALN	TiN	N (µk20)	HTA	HTiN	HN (µk10)
1.0	5	761L-1.0	■	■	■	■	□	■	751R-1.0	■	■	■	■	□	■
1.5	8	761L-1.5	■	■	■	■	□	■	751R-1.5	■	■	■	■	□	■
1.8	8	761L-1.8	■	■	■				751R-1.8	■	■	■	■	□	■
2.0	10	761L-2.0	■	■	■	■	□	■	751R-2.0	■	■	■	■	■	■
2.2	10	761L-2.2	■	■	■				751R-2.2	■	■	■			
2.5	10	761L-2.5	■	■	■				751R-2.5	■	■	■	■	■	■
3.0	10	761L-3.0	■	■	■				751R-3.0	■	■	■	■	□	■

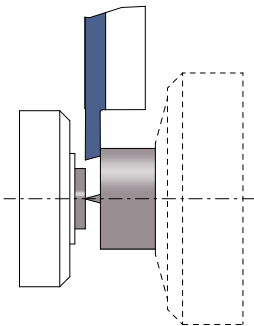

Tronçonnage

Coupe déportée

Abstechen

Versetztes Schneiden

Parting off

Cut off line

## 761LS / 751RS

**Cut L**

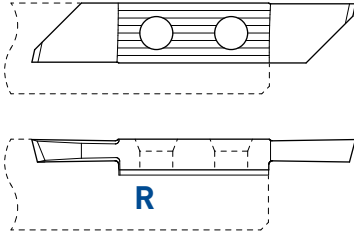

**Cut R**

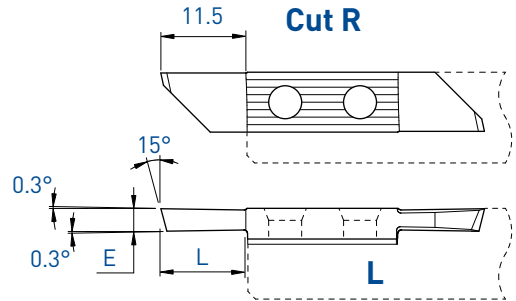

**R (L)**

Coupe à gauche déportée  
Versetztes Linksschneiden  
Left cut off line

**L (R)**

Coupe à droite déportée  
Versetztes Rechtsschneiden  
Right cut off line

E	L	Art. N°	TiALN			HTA		HN (µk10)	Art. N°	TiALN			HTA		HN (µk10)
			TiN	N (µk20)		HTIN				TiN	N (µk20)		HTIN		
1.0	5.5	761LS-1.0	■	■	■	■	□	■	751RS-1.0	■	■	■	■	□	■
1.5	8	761LS-1.5	■	■	■	■	□	■	751RS-1.5	■	■	■	■	□	■
2.0	11.5	761LS-2.0	■	■	■				751RS-2.0	■	■	■	■	■	■
2.2	11.5	761LS-2.2	■	■	■				751RS-2.2	■	■	■			
2.5	11.5	761LS-2.5	■	■	■				751RS-2.5	■	■	■	■	□	■
3.0	11.5	761LS-3.0	■	■	■				751RS-3.0	■	■	■			

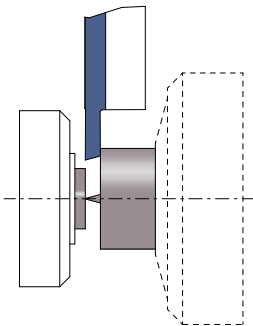

Tronçonnage

Coupe déportée

Abstechen

Versetztes Schneiden

Parting off

Cut off line

## 761L-R05 / 751R-R05

### Cut L

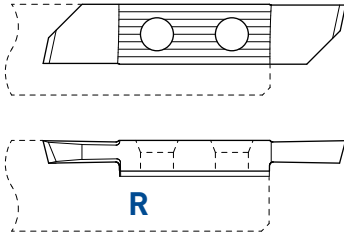

### Cut R

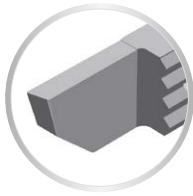
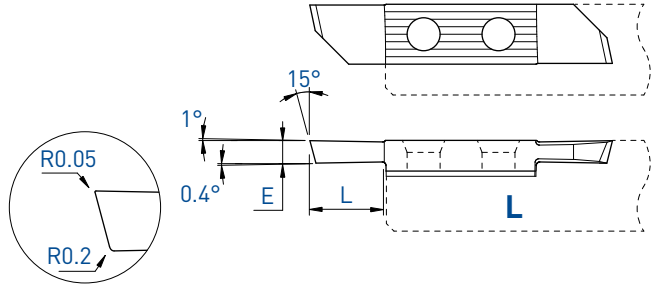

### R (L)

Coupe à gauche déportée  
Versetztes Linksschneiden  
Left cut off line

### L (R)

Coupe à droite déportée  
Versetztes Rechtsschneiden  
Right cut off line

E	L	Art. N°	TiALN	TiN	N (µk20)	HTA	HTiN	HN (µk10)	Art. N°	TiALN	TiN	N (µk20)	HTA	HTiN	HN (µk10)
1.5	7.5	<b>761L-1.5-R05</b>	■	■	■				<b>751R-1.5-R05</b>	■	■	■			
2.0	10	<b>761L-2.0-R05</b>	■	■	■				<b>751R-2.0-R05</b>	■	■	■			

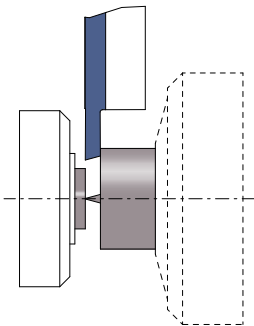

Tronçonnage

Abstechen

Parting off

Coupe déportée

Versetztes Schneiden

Cut off line

761LX4 / 751RX4

Cut L

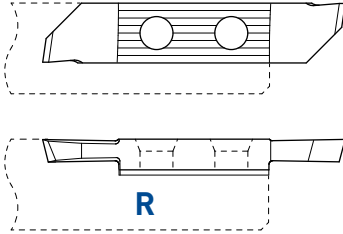

Cut R

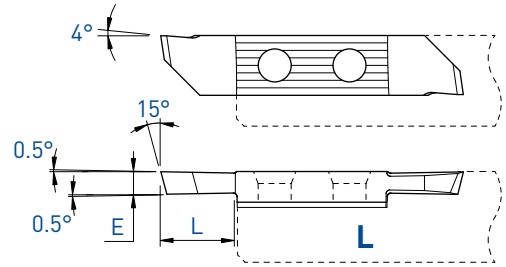

R (L)

Coupe à gauche déportée  
Versetztes Linksschneiden  
Left cut off line

L (R)

Coupe à droite déportée  
Versetztes Rechtsschneiden  
Right cut off line

E	L	Art. N°	TiALN	TiN	N (µk20)	HTA	HTiN	HN (µk10)	Art. N°	TiALN	TiN	N (µk20)	HTA	HTiN	HN (µk10)
1.5	7.5	-							751RX4-1.5	■	■	■			
2.0	10	761LX4-2.0	■	■	■				751RX4-2.0	■	■	■	■	□	■
2.5	10	-							751RX4-2.5	■	■	■			

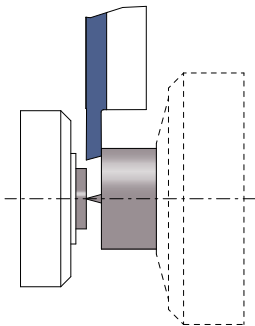

Tronçonnage

Coupe déportée

Abstechen

Versetztes Schneiden

Parting off

Cut off line

## 761LXF / 751RXF

Cut L

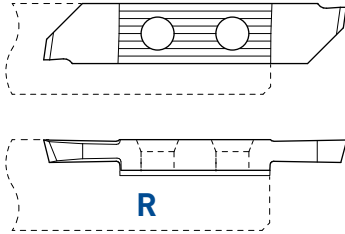

Cut R

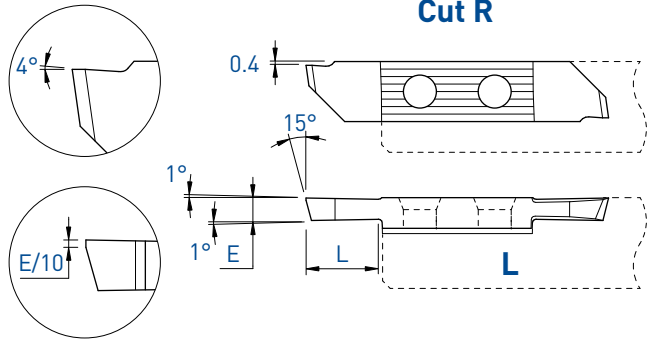

R (L)

Coupe à gauche déportée  
Versetztes Linksschneiden  
Left cut off line

L (R)

Coupe à droite déportée  
Versetztes Rechtsschneiden  
Right cut off line

E	L	Art. N°	TiALN	TiN	N (µk20)	HTA	HTiN	HN (µk10)	Art. N°	TiALN	TiN	N (µk20)	HTA	HTiN	HN (µk10)
1.5	7.5	-							751RXF-1.5	■	■	■	■	□	■
2.0	10	761LXF-2.0	■	■	■				751RXF-2.0	■	■	■	■	■	■
2.5	10	761LXF-2.5	■	■	■				751RXF-2.5	■	■	■	■	□	■
3.0	10	761LXF-3.0	■	■	■				751RXF-3.0	■	■	■	■	□	■

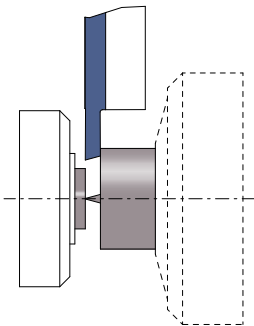

Tronçonnage

Abstechen

Parting off

Coupe déportée

Versetztes Schneiden

Cut off line

## 761LX12 / 751RX12

Cut L

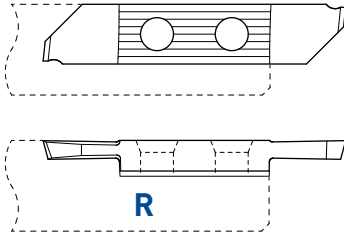

Cut R

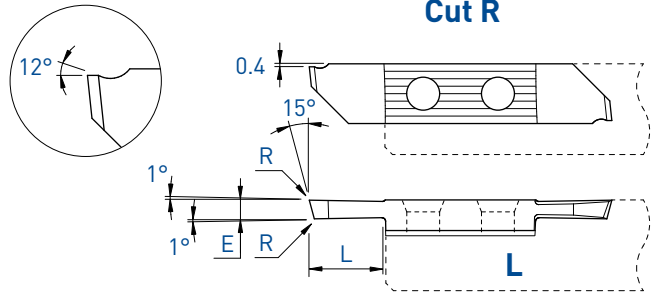

R (L)

Coupe à gauche déportée  
Versetztes Linksschneiden  
Left cut off line

L (R)

Coupe à droite déportée  
Versetztes Rechtsschneiden  
Right cut off line

E	L	R	Art. N°	TiALN	TiN	N [µk20]	HTA	HTiN	HN [µk10]	Art. N°	TiALN	TiN	N [µk20]	HTA	HTiN	HN [µk10]
1.5	7.5	0.03	-							751RX12-1.5	■	■	■			
2.0	10	0.03	761LX12	■	■	■				751RX12-2.0	■	■	■	■	■	■

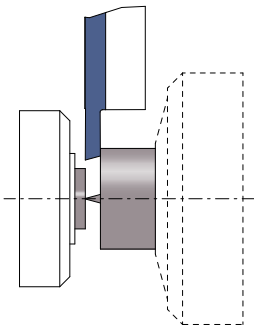



Tronçonnage

Coupe déportée

Abstechen

Versetztes Schneiden

Parting off

Cut off line

## 761LX25 / 751RX25

### Cut L

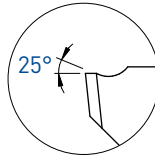
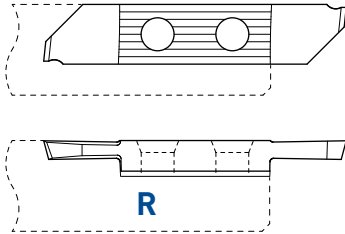

### Cut R

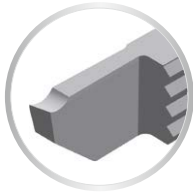
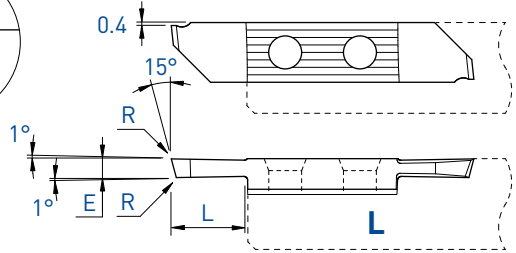

#### R (L)

Coupe à gauche déportée  
Versetztes Linksschneiden  
Left cut off line

#### L (R)

Coupe à droite déportée  
Versetztes Rechtsschneiden  
Right cut off line

E	L	R	Art. N°	TiALN	TiN	N [µk20]	HTA	HTiN	HN [µk10]	Art. N°	TiALN	TiN	N [µk20]	HTA	HTiN	HN [µk10]
2.0	10	0.03	761LX25-2.0	■	■	■				751RX25-2.0	■	■	■			

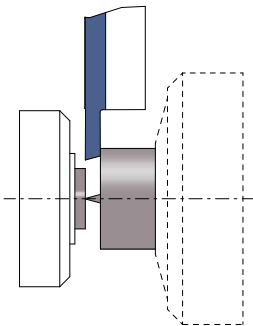

Tronçonnage

Abstechen

Parting off

Coupe déportée

Versetztes Schneiden

Cut off line

751RU

## Cut R

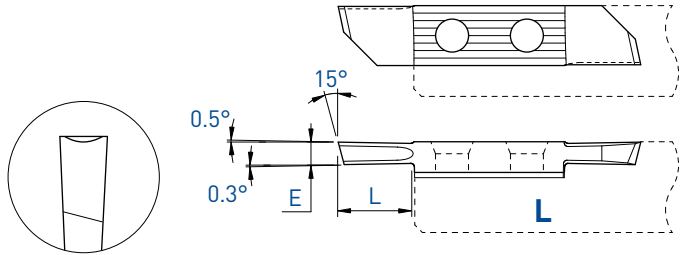

**NEW**

## L (R)

Coupe à droite déportée  
Versetztes Rechtsschneiden  
Right cut off line

E	L	Art. N°	TiALN	TiN	N (µk20)	HTA	HTiN	HN (µk10)
1.5	7.5	751RU-1.5	■	□	■			
2.0	10	751RU-2.0	■	■	■	□	□	□

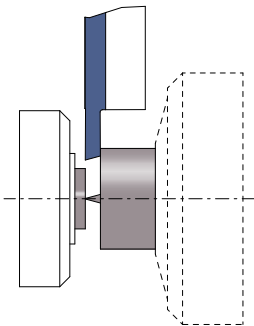

Tronçonnage

Coupe déportée

Abstechen

Versetztes Schneiden

Parting off

Cut off line

## 761NFX / 751NFX

### Cut L

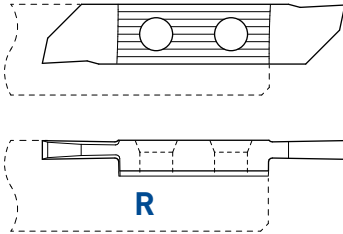

### Cut R

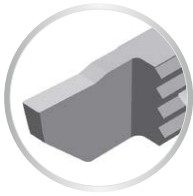
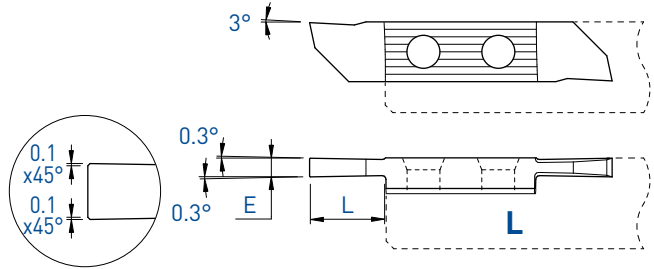

### R (L)

Coupe à gauche déportée  
Versetztes Linksschneiden  
Left cut off line

### L (R)

Coupe à droite déportée  
Versetztes Rechtsschneiden  
Right cut off line

E	L	Art. N°	TiALN	TiN	N (µk20)	HTA	HTiN	HN (µk10)	Art. N°	TiALN	TiN	N (µk20)	HTA	HTiN	HN (µk10)
2.0	10	761NFX-2.0	■	■	■	■	□	■	751NFX-2.0	■	■	■	■	□	■
2.5	10	761NFX-2.5	■	■	■				751NFX-2.5	■	■	■			
3.0	10	761NFX-3.0	■	■	■				751NFX-3.0	■	■	■			

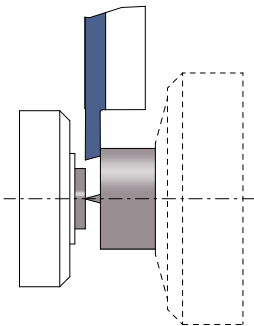

Tronçonnage

Coupe déportée

Abstechen

Versetztes Schneiden

Parting off

Cut off line

761LD / 751RD

Cut L

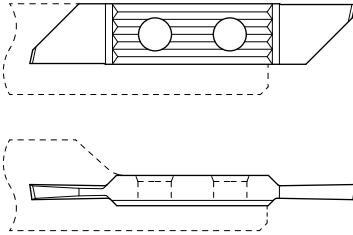

R

Cut R

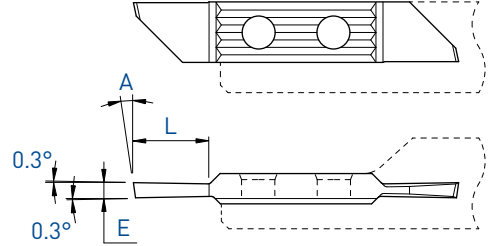

L

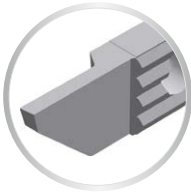

R (L)

Coupe à gauche déportée  
Versetztes Linksschneiden  
Left cut off line

L (R)

Coupe à droite déportée  
Versetztes Rechtsschneiden  
Right cut off line

A	E	L	Art. N°	TIALN	TIN	N (µk20)	HTA	HTIN	HN (µk10)	Art. N°	TIALN	TIN	N (µk20)	HTA	HTIN	HN (µk10)
8°	1.0	5	761LD-1.0-8°	■	■	■	■	□	■	751RD-1.0-8°	■	■	■	■	□	■
15°	1.0	5	761LD-1.0-15°	■	■	■	■	□	■	751RD-1.0-15°	■	■	■	■	□	■
8°	1.2	5	761LD-1.2-8°	■	■	■				751RD-1.2-8°	■	■	■	■	□	■
8°	1.5	8	761LD-1.5-8°	■	■	■				751RD-1.5-8°	■	■	■	■	■	■
15°	1.5	8	761LD-1.5-15°	■	■	■				751RD-1.5-15°	■	■	■	■	□	■
8°	1.6	8	761LD-1.6-8°	■	■	■				751RD-1.6-8°	■	■	■			
8°	1.8	10	761LD-1.8-8°	■	■	■				751RD-1.8-8°	■	■	■	■	□	■
8°	2.0	10	761LD-2.0-8°	■	■	■				751RD-2.0-8°	■	■	■	■	□	■
15°	2.0	10	761LD-2.0-15°	■	■	■	■	□	■	751RD-2.0-15°	■	■	■	■	□	■
8°	2.5	10	-							751RD-2.5-8°	■	■	■	■	□	■

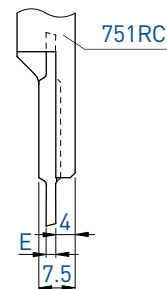
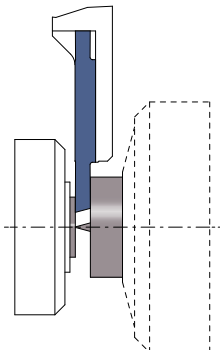

Tronçonnage

Coupe déportée

Abstechen

Versetztes Schneiden

Parting off

Cut off line

## 751RAS

### Cut R

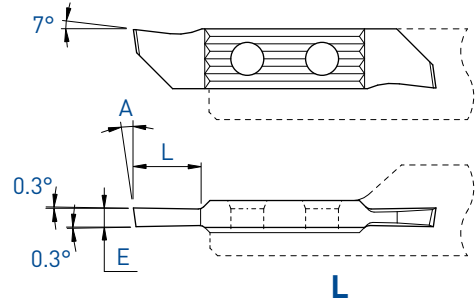

### L (R)

Coupe à droite déportée  
Versetztes Rechtsschneiden  
Right cut off line

A	E	L	Art. N°	TiAlN	TiN	N (µk20)	HTA	HTiN	HN (µk10)
8°	1.6	7.5	751RAS-1.6-8°	■	■	■			
8°	2.0	9	751RAS-2.0-8°	■	■	■	■	□	■
8°	2.5	9	751RAS-2.5-8°	■	■	■			
15°	1.6	7.5	751RAS-1.6-15°	■	■	■	■	□	■
15°	2.0	9	751RAS-2.0-15°	■	■	■			
15°	2.5	9	751RAS-2.5-15°	■	■	■			

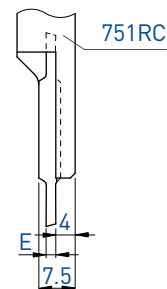
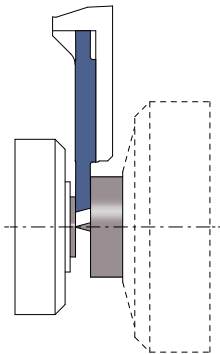

# TOP-Line

Tourneur avant  
Vorwärts drehen  
Front turning

752 / 762

L

R

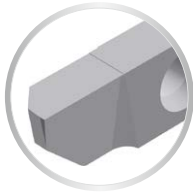
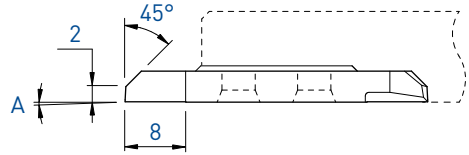
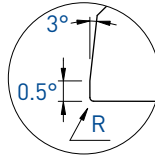
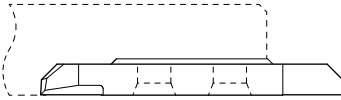
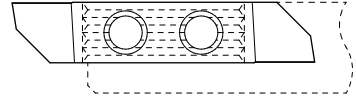
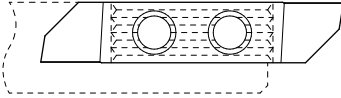

L

R

A	R	Art. N°	TiALN	TiN	N (µk20)	HTA	HTiN	HN (µk10)	Art. N°	TiALN	TiN	N (µk20)	HTA	HTiN	HN (µk10)
0°	0	752	■	■	■	■	□	■	762	■	■	■	■	□	■
0°	0.2	-							762-R20	■	■	■	■	□	■
3°	0	752-3°	■	■	■				762-3°	■	■	■	■	□	■

7XX-XX-B



Sur demande pour serrage type B, voir page 1.03  
Wahlweise für B-Spannsystem, siehe Seite 1.03  
On request for B clamping system, see page 1.03

Tourneur avant  
Vorwärts drehen  
Front turning

## 752PX / 762PX

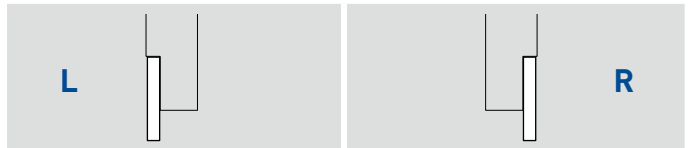
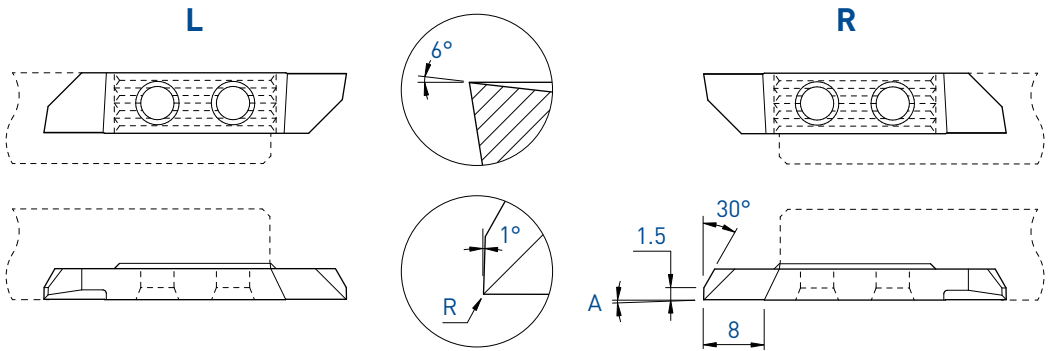

A	R	Art. N°	TiALN	TiN	N (µk20)	HTA	HTiN	HN (µk10)	Art. N°	TiALN	TiN	N (µk20)	HTA	HTiN	HN (µk10)
0°	0	752PX	■	■	■				762PX	■	■	■			

7XX-XX-B



Sur demande pour serrage type B, voir page 1.03  
Wahlweise für B-Spannsystem, siehe Seite 1.03  
On request for B clamping system, see page 1.03

# TOP-Line

Tourneur avant  
Vorwärts drehen  
Front turning

752X / 762X

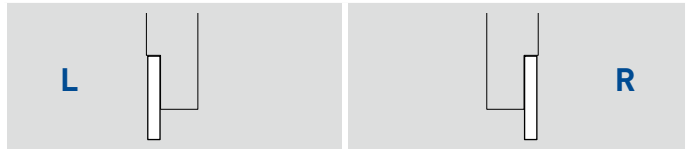
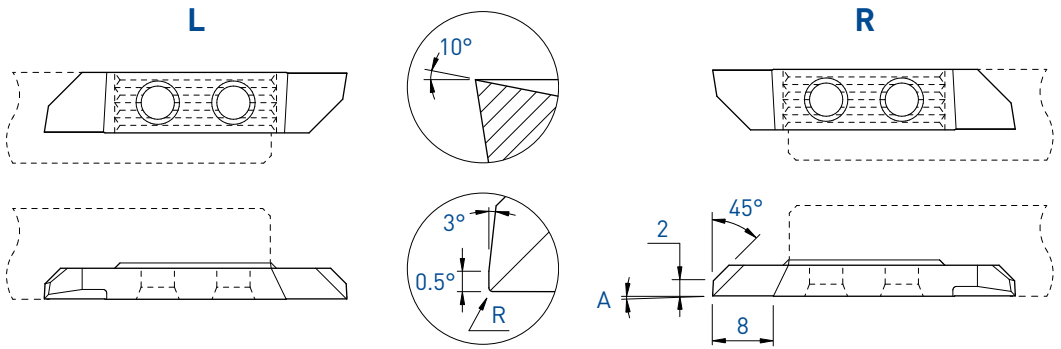

A	R	Art. N°	TiALN	TiN	N (µk20)	HTA	HTiN	HN (µk10)	Art. N°	TiALN	TiN	N (µk20)	HTA	HTiN	HN (µk10)
0°	0	752X	■	■	■	□	■	■	762X	■	■	■	■	■	■
0°	0.2	752X-R20	■	■	■				762X-R20	■	■	■	□	■	■

7XX-XX-B



Sur demande pour serrage type B, voir page 1.03  
Wahlweise für B-Spannsystem, siehe Seite 1.03  
On request for B clamping system, see page 1.03



Tourneur avant  
Vorwärts drehen  
Front turning

## 762ZX

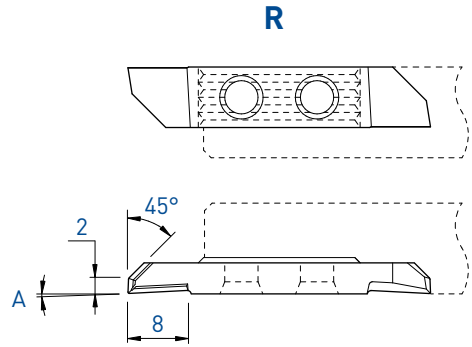
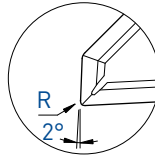
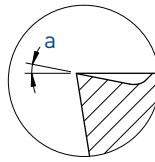

**NEW**

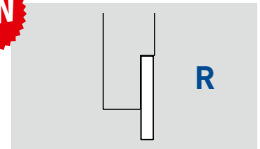

A	a	R	Art. N°	TiALN	TiN	N (µm20)
3°	10°	0.08	<b>762ZX10-R08</b>	■	□	
3°	10°	0.2	<b>762ZX10-R20</b>	■	□	

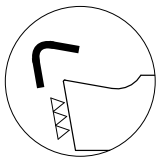

Arête de coupe honée  
Gehonte Schneidkante  
Honed edge

f min: 0.02 mm/U

**7XX-XX-B**



Sur demande pour serrage type B, voir page 1.03  
Wahlweise für B-Spannsystem, siehe Seite 1.03  
On request for B clamping system, see page 1.03

# TOP-Line

Tourneur multifonction

Mehrweck Drehen

Multifunction turning

752S / 762S

753S / 763S

L

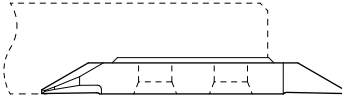
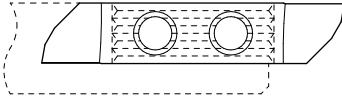

Tourneur avant  
Vorwärts drehen  
Front turning

R

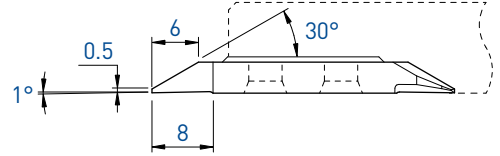
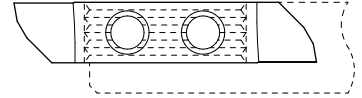

L						R							
Art. N°	TiAlN	TiN	N (µk20)	HTA	HTiN	HN (µk10)	Art. N°	TiAlN	TiN	N (µk20)	HTA	HTiN	HN (µk10)
752S05	■	■	■	■	□	■	762S05	■	■	■	■	■	■

L

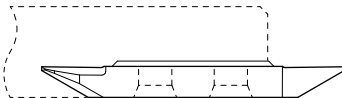
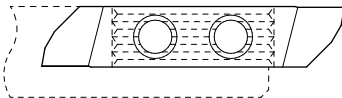

Tourneur arrière  
Rückwärts drehen  
Back turning

R

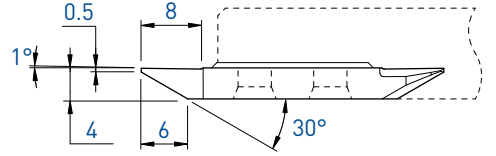
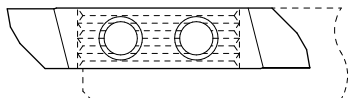

L						R							
Art. N°	TiAlN	TiN	N (µk20)	HTA	HTiN	HN (µk10)	Art. N°	TiAlN	TiN	N (µk20)	HTA	HTiN	HN (µk10)
753S05	■	■	■	■	■	■	763S05	■	■	■	■	■	■

**Tourneur arrière**  
**Rückwärts drehen**  
**Back turning**

**753 / 763**

**L**

**R**

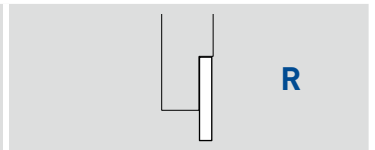
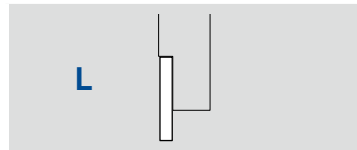
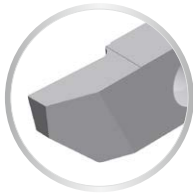
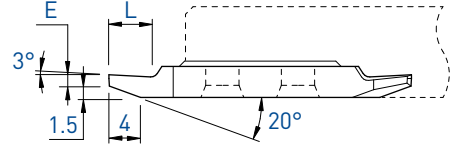
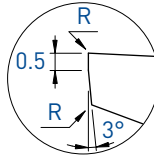
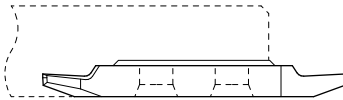
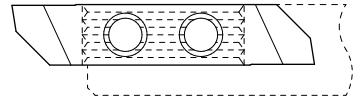
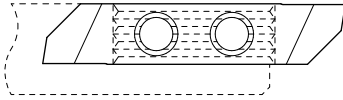

E	L	R	Art. N°	TiAlN			HTA			Art. N°	TiAlN			HTA		
				TiN	N (µk20)	HN (µk10)	HTiN	HTiN	HN (µk10)		TiN	N (µk20)	HN (µk10)	HTiN	HTiN	HN (µk10)
1.0	5	0	753-1.0	■	■	■				763-1.0	■	■	■	■	■	■
1.0	5	0.08	753-1.0-R08	■	■	■				763-1.0-R08	■	■	■	■	□	■
1.5	6	0	753-1.5	■	■	■				763-1.5	■	■	■	■	□	■
2.0	7.5	0	753-2.0	■	■	■				763-2.0	■	■	■	■	□	■
2.5	9	0	753-2.5	■	■	■				763-2.5	■	■	■			

**7XX-XX-B**



Sur demande pour serrage type B, voir page 1.03  
 Wahlweise für B-Spannsystem, siehe Seite 1.03  
 On request for B clamping system, see page 1.03

# TOP-Line

Tourneur arrière  
Rückwärts drehen  
Back turning

753X / 763X

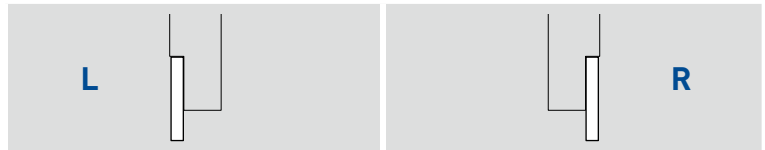
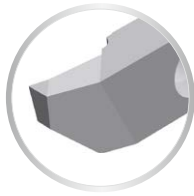
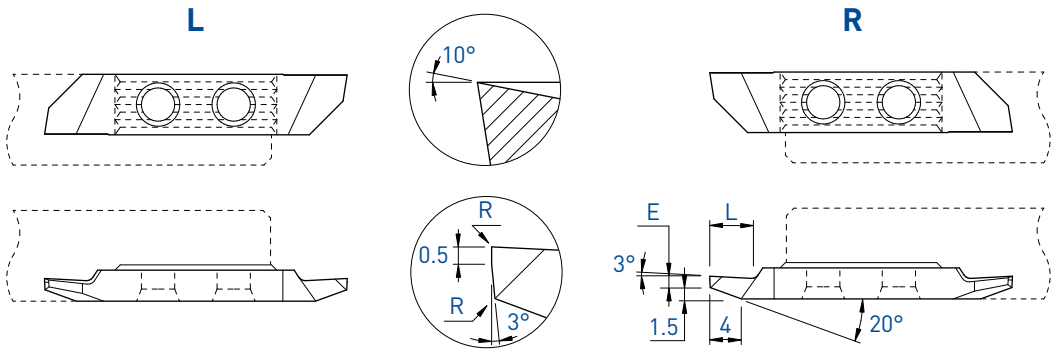

E	L	R	Art. N°	TiAlN			HTA			Art. N°	TiAlN			HTA		
				Ti	Al	N	HTA	HTiN	HN		Ti	Al	N	HTA	HTiN	HN
1.0	5	0	753X-1.0	■	■	■				763X-1.0	■	■	■	■	□	■
1.0	5	0.08	753X-1.0-R08	■	■	■	■	□	■	763X-1.0-R08	■	■	■	■	□	■
1.0	5	0.2	753X-1.0-R20	■	■	■				763X-1.0-R20	■	■	■			
1.5	6	0	753X-1.5	■	■	■				763X-1.5	■	■	■	■	□	■
1.5	6	0.2	753X-1.5-R20	■	■	■				763X-1.5-R20	■	■	■			
2.0	7.5	0	753X-2.0	■	■	■				763X-2.0	■	■	■			
2.0	7.5	0.2	753X-2.0-R20	■	■	■				763X-2.0-R20	■	■	■			
2.5	9	0	753X-2.5	■	■	■				763X-2.5	■	■	■			
2.5	9	0.2	753X-2.5-R20	■	■	■				763X-2.5-R20	■	■	■			

7XX-XX-B



Sur demande pour serrage type B, voir page 1.03  
Wahlweise für B-Spannsystem, siehe Seite 1.03  
On request for B clamping system, see page 1.03

Tourneur arrière  
Rückwärts drehen  
Back turning

## 753XS / 763XS

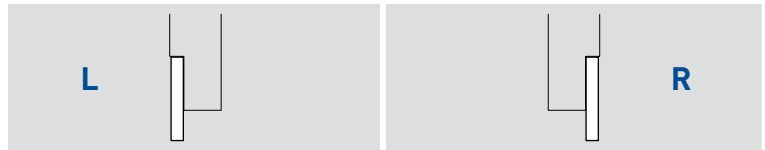
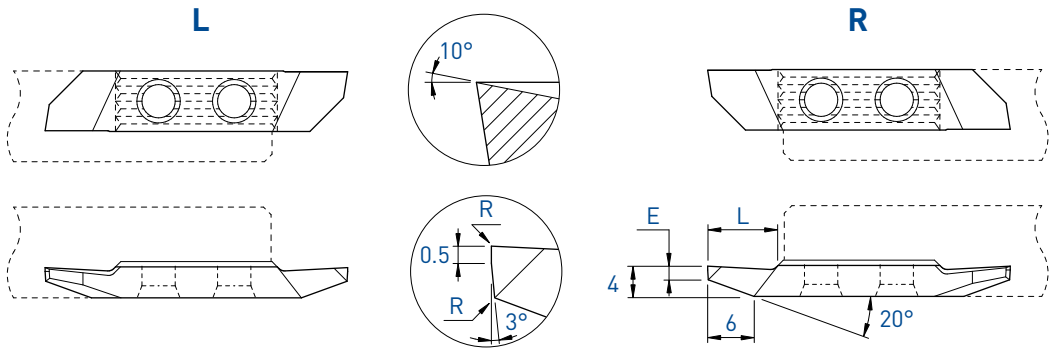

E	L	R	Art. N°	TiALN	TiN	N (µk20)	HTA	HTiN	HN (µk10)	Art. N°	TiALN	TiN	N (µk20)	HTA	HTiN	HN (µk10)
1.8	9	0	753XS-1.8	■	■	■				763XS-1.8	■	■	■	■	□	■
1.8	9	0.2	753XS-1.8-R20	■	■	■				763XS-1.8-R20	■	■	■			

7XX-XX-B



Sur demande pour serrage type B, voir page 1.03  
Wahlweise für B-Spannsystem, siehe Seite 1.03  
On request for B clamping system, see page 1.03

# TOP-Line

Tourneur arrière  
Rückwärts drehen  
Back turning

753VX-8° / 763VX-8°

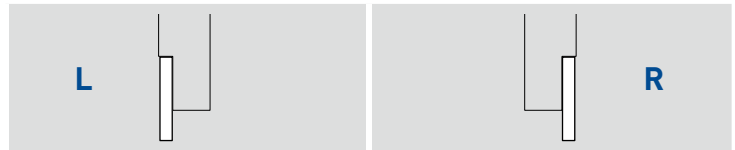
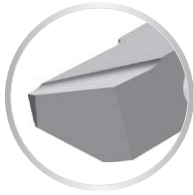
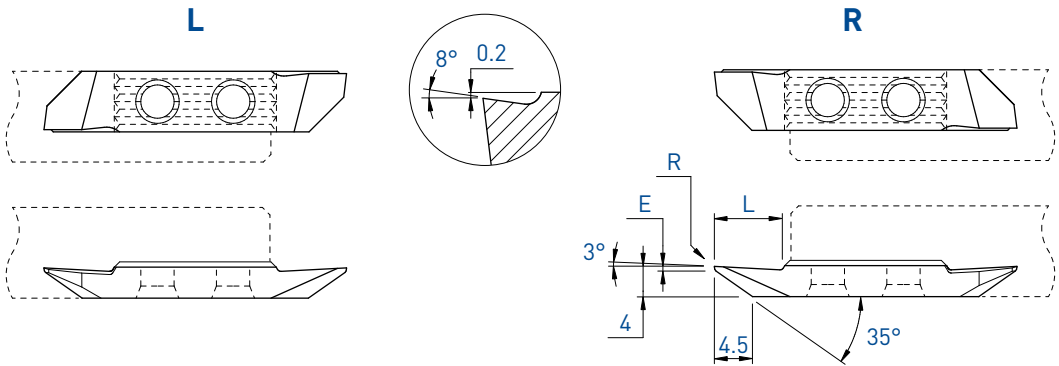

E	L	R	Art. N°	L			R									
				TiALN	TiN	N (µk20)	HTA	HTiN	HN (µk10)	TiALN	TiN	N (µk20)	HTA	HTiN	HN (µk10)	
~ 1.0	9	0	753VX-8°	■	■	■				763VX-8°	■	■	■	■	■	■
~ 1.0	9	0.08	753VX-8°-R08	■	■	■				763VX-8°-R08	■	■	■	□	□	□
~ 1.0	9	0.20	-							763VX-8°-R20	■	■	■			

7XX-XX-B



Sur demande pour serrage type B, voir page 1.03  
Wahlweise für B-Spannsystem, siehe Seite 1.03  
On request for B clamping system, see page 1.03

Tourneur arrière  
Rückwärts drehen  
Back turning

## 753VX-805 / 763VX-805

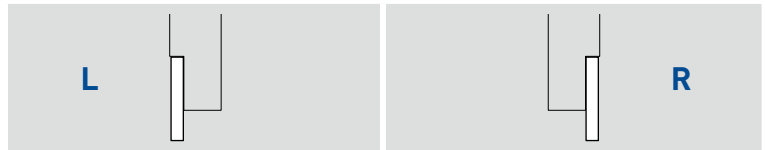
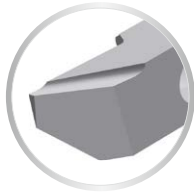
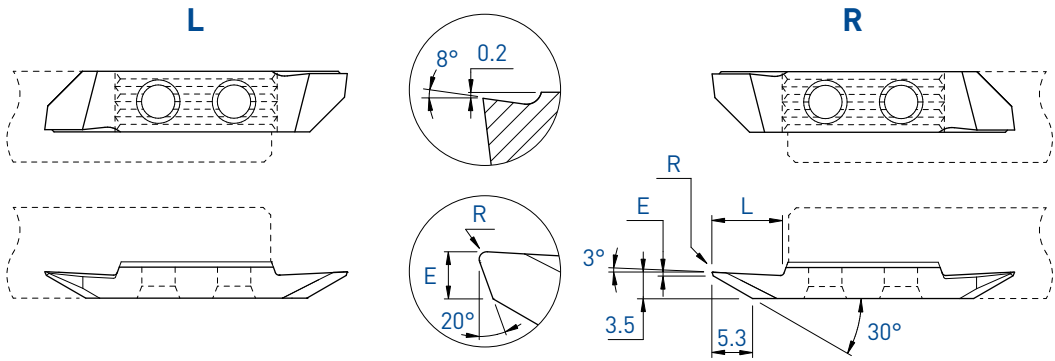

E	L	R	Art. N°	TiALN	TiN	N (µk20)	HTA	HTiN	HN (µk10)	Art. N°	TiALN	TiN	N (µk20)	HTA	HTiN	HN (µk10)
0.5	9	0.08	753VX-805-R08	■	■	■	■	□	■	763VX-805-R08	■	■	■	■	□	■

7XX-XX-B



Sur demande pour serrage type B, voir page 1.03  
Wahlweise für B-Spannsystem, siehe Seite 1.03  
On request for B clamping system, see page 1.03

# TOP-Line

Tourneur arrière  
Rückwärts drehen  
Back turning

763VX-800

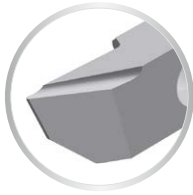
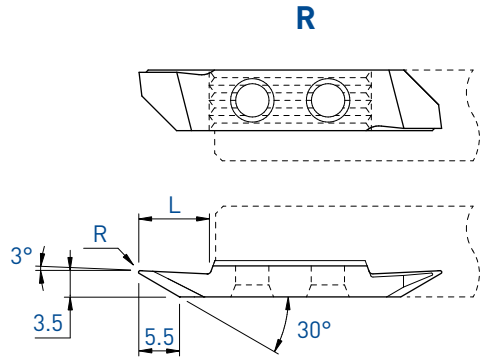
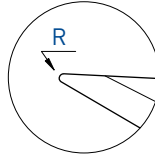
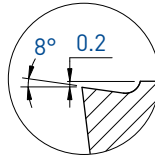

**NEW**

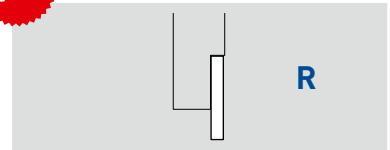

L	R	Art. N°	TiALN	TiN	N (µk20)	HTA	HTiN	HN (µk10)
9	0.08	763VX-800-R08	■	■	■	■	□	■
9	0.2	763VX-800-R20	■	■	■	■	□	■

7XX-XX-B



Sur demande pour serrage type B, voir page 1.03  
Wahlweise für B-Spannsystem, siehe Seite 1.03  
On request for B clamping system, see page 1.03



**Tourneur arrière**  
**Rückwärts drehen**  
**Back turning**

**753VX-15° / 763VX-15°**

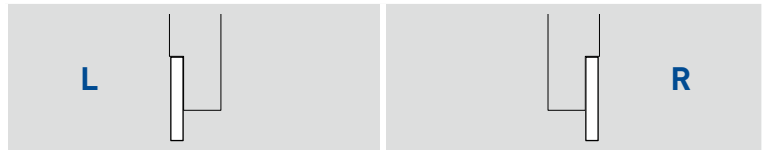
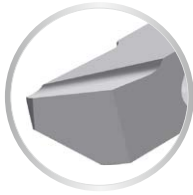
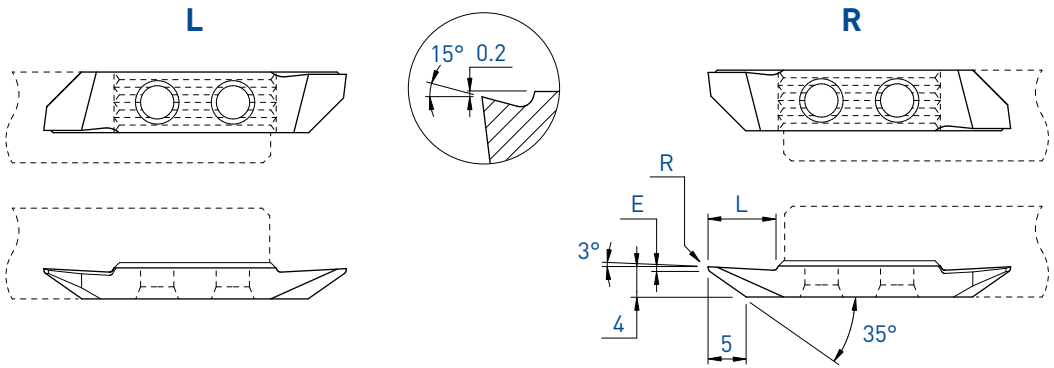

			L				R									
E	L	R	Art. N°	TiALN	TiN	N (µk20)	HTA	HTiN	HN (µk10)	Art. N°	TiALN	TiN	N (µk20)	HTA	HTiN	HN (µk10)
0.6	9	0	753VX-15°	■	■	■				763VX-15°	■	■	■	■	□	■
0.6	9	0.08	753VX-15°-R08	■	■	■				763VX-15°-R08	■	■	■	■	□	■

**7XX-XX-B**



Sur demande pour serrage type B, voir page 1.03  
 Wahlweise für B-Spannsystem, siehe Seite 1.03  
 On request for B clamping system, see page 1.03

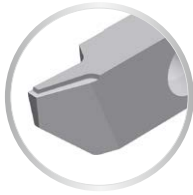
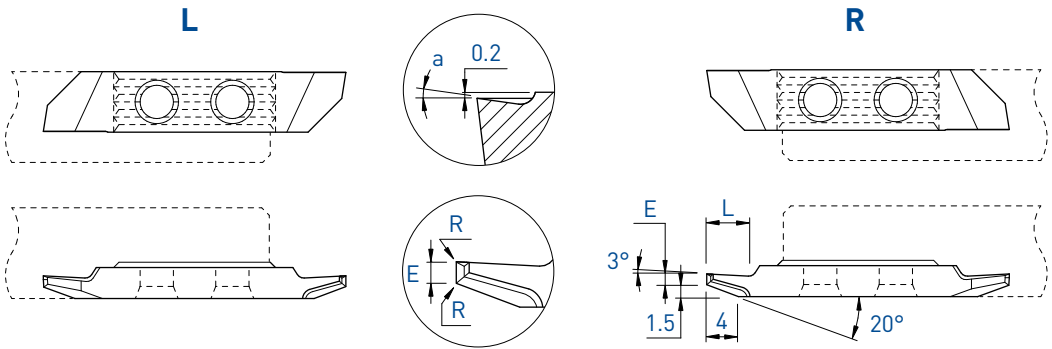

Pour un meilleur contrôle des copeaux  
Für eine bessere Spankontrolle  
For a better chip-control

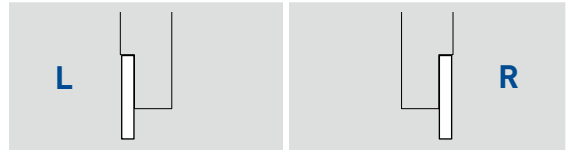

E	L	a	R	Art. N°	TiAlN	TiN	N (µk20)	Art. N°	TiAlN	TiN	N (µk20)
1.0	5	10°	0.01	753ZX10-1.0	■	□		763ZX10-1.0	■	■	
1.0	5	10°	0.08	-				763ZX10-1.0-R08	■	■	
1.0	5	10°	0.2	-				763ZX10-1.0-R20	■	■	

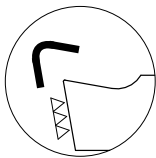

Arête de coupe honée  
Gehonte Schneidkante  
Honed edge

f min: 0.02 mm/U

7XX-XX-B



Sur demande pour serrage type B, voir page 1.03  
Wahlweise für B-Spannsystem, siehe Seite 1.03  
On request for B clamping system, see page 1.03

**Tourneur arrière pré-coupe**  
**Rückwärts drehen vorstechen**  
**Back turning pre-parting off**

**753P / 763P**

**L**

**R**

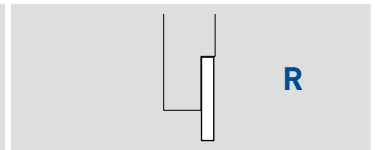
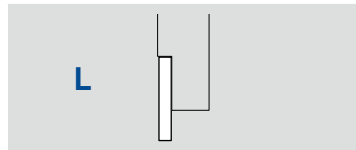
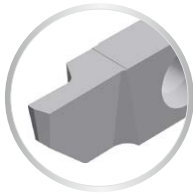
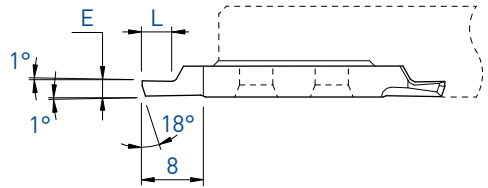
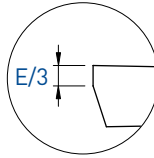
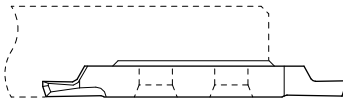
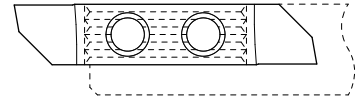
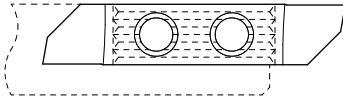

E	L	Art. N°	L			R									
			TiALN	TiN	N (µk20)	HTA	HTiN	HN (µk10)	Art. N°	TiALN	TiN	N (µk20)	HTA	HTiN	HN (µk10)
1.5	3	753P-1.5	■	■	■				763P-1.5	■	■	■			
1.8	3.5	753P-1.8	■	■	■				763P-1.8	■	■	■			
2.0	4	753P-2.0	■	■	■				763P-2.0	■	■	■			
2.2	4.5	753P-2.2	■	■	■				763P-2.2	■	■	■			
2.5	5	753P-2.5	■	■	■				763P-2.5	■	■	■			
3.0	6	753P-3.0	■	■	■				763P-3.0	■	■	■			

**7XX-XX-B**



Sur demande pour serrage type B, voir page 1.03  
 Wahlweise für B-Spannsystem, siehe Seite 1.03  
 On request for B clamping system, see page 1.03

L

R

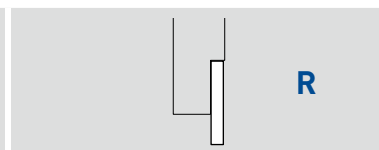
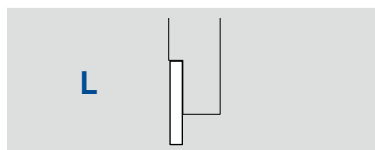
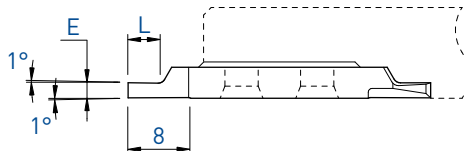
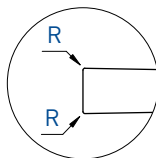
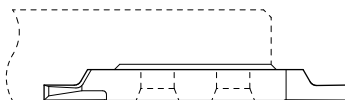
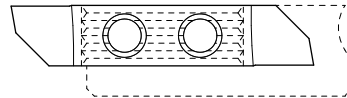
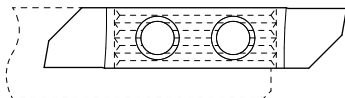

E	L	R	Art. N°	TiALN	TiN	N (µk20)	HTA	HTiN	HN (µk10)	Art. N°	TiALN	TiN	N (µk20)	HTA	HTiN	HN (µk10)
0.5	1.5	0	754-0.5	■	■	■				764-0.5	■	■	■			
0.75	2	0	754-0.75	■	■	■				764-0.75	■	■	■			
0.8	2	0	-							764-0.8	■	■	■	■	□	■
0.95	3	0	754-0.95	■	■	■				764-0.95	■	■	■			
1.0	2.5	0	754-1.0	■	■	■				764-1.0	■	■	■			
1.0	2.5	0.08	754-1.0-R08	■	■	■				764-1.0-R08	■	■	■		□	■
1.2	3	0	754-1.2	■	■	■				764-1.2	■	■	■		□	■
1.5	3	0	754-1.5	■	■	■	■	□	■	764-1.5	■	■	■		□	■
1.5	3	0.08	754-1.5-R08	■	■	■		□	■	764-1.5-R08	■	■	■		□	■
1.5	3	0.2	-							764-1.5-R20	■	■	■		□	■
1.8	4	0	754-1.8	■	■	■				764-1.8	■	■	■			
2.0	4	0	754-2.0	■	■	■	■	□	■	764-2.0	■	■	■		□	■
2.0	4	0.08	754-2.0-R08	■	■	■		□	■	764-2.0-R08	■	■	■		□	■
2.0	4	0.2	754-2.0-R20	■	■	■				764-2.0-R20	■	■	■		□	■
2.5	6	0	754-2.5	■	■	■				764-2.5	■	■	■		□	■
2.5	6	0.2	-							764-2.5-R20	■	■	■		□	■
3.0	6	0	754-3.0	■	■	■	■	□	■	764-3.0	■	■	■		□	■
3.0	6	0.08	754-3.0-R08	■	■	■				764-3.0-R08	■	■	■		□	■
3.0	6	0.2	754-3.0-R20	■	■	■		□	■	764-3.0-R20	■	■	■			
4.0	8	0	754-4.0	■	■	■	■	■	■	764-4.0	■	■	■		□	■

7XX-XX-B



Sur demande pour serrage type B, voir page 1.03  
Wahlweise für B-Spannsystem, siehe Seite 1.03  
On request for B clamping system, see page 1.03

Foncer-tourner

Einstecken und drehen

Grooving and turning

## 754VS / 764VS

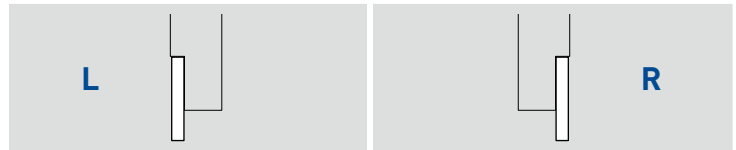
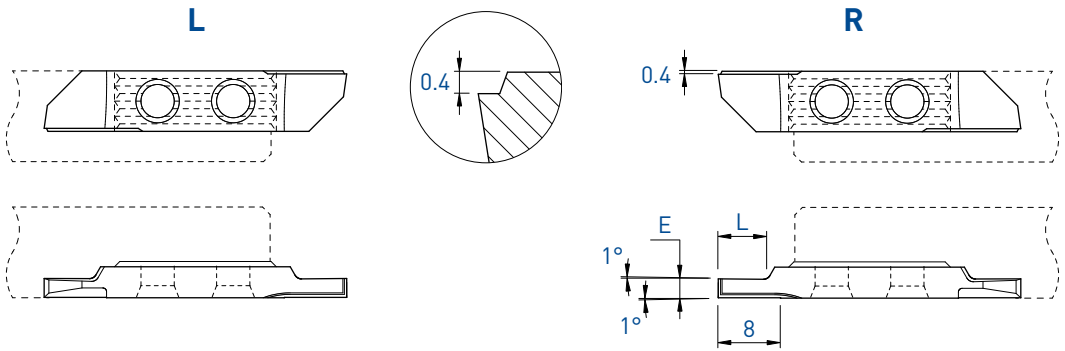

E	L	Art. N°	L			R									
			TiALN	TiN	N (µk20)	HTA	HTiN	HN (µk10)	Art. N°	TiALN	TiN	N (µk20)	HTA	HTiN	HN (µk10)
1.0	2	754VS-1.0	■	■	■				764VS-1.0	■	■	■			
1.2	2.5	754VS-1.2	■	■	■	■	□	■	764VS-1.2	■	■	■			
1.5	3	754VS-1.5	■	■	■				764VS-1.5	■	■	■			
2.0	4	754VS-2.0	■	■	■				764VS-2.0	■	■	■			
2.5	6	754VS-2.5	■	■	■				764VS-2.5	■	■	■	■	□	■
3.0	6	754VS-3.0	■	■	■				764VS-3.0	■	■	■			

7XX-XX-B



Sur demande pour serrage type B, voir page 1.03  
Wahlweise für B-Spannsystem, siehe Seite 1.03  
On request for B clamping system, see page 1.03

■ = disponible / verfügbar / available

□ = selon disponibilité du stock / jenach Lagerverfügbarkeit / depending on stock availability

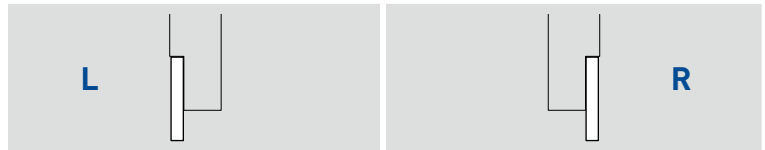
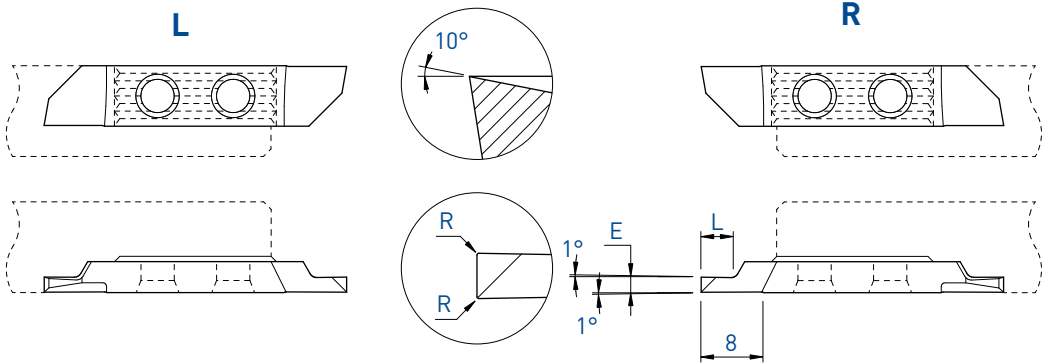

E	L	R	Art. N°	L			R									
				TiALN	TiN	N (µk20)	HTA	HTiN	HN (µk10)	Art. N°	TiALN	TiN	N (µk20)	HTA	HTiN	HN (µk10)
1.0	2.5	0	754X-1.0	■	■	■	■	■	■	764X-1.0	■	■	■	■	□	■
1.0	2.5	0.08	754X-1.0-R08	■	■	■	■	□	■	764X-1.0-R08	■	■	■	■	□	■
1.0	2.5	0.2	-							764X-1.0-R20	■	■	■			
1.2	3	0	754X-1.2	■	■	■				764X-1.2	■	■	■	■	□	■
1.2	3	0.08	-							764X-1.2-R08	■	■	■			
1.5	3	0	754X-1.5	■	■	■	■	□	■	764X-1.5	■	■	■	■	■	■
1.5	3	0.08	754X-1.5-R08	■	■	■	■	□	■	764X-1.5-R08	■	■	■	■	□	■
1.5	3	0.2	754X-1.5-R20	■	■	■				764X-1.5-R20	■	■	■	■	■	■
1.8	4	0	754X-1.8	■	■	■				764X-1.8	■	■	■			
1.8	4	0.2	-							764X-1.8-R20	■	■	■			
2.0	4	0	754X-2.0	■	■	■	■	□	■	764X-2.0	■	■	■	■	■	■
2.0	4	0.08	754X-2.0-R08	■	■	■	■	□	■	764X-2.0-R08	■	■	■	■	□	■
2.0	4	0.2	754X-2.0-R20	■	■	■				764X-2.0-R20	■	■	■	■	□	■
2.5	6	0	754X-2.5	■	■	■	■	■	■	764X-2.5	■	■	■	■	■	■
2.5	6	0.2	754X-2.5-R20	■	■	■	■	□	■	764X-2.5-R20	■	■	■	■	□	■
3.0	6	0	754X-3.0	■	■	■				764X-3.0	■	■	■	■	□	■
3.0	6	0.08	754X-3.0-R08	■	■	■				764X-3.0-R08	■	■	■	■	□	■
3.0	6	0.2	754X-3.0-R20	■	■	■				764X-3.0-R20	■	■	■	■	□	■
4.0	8	0	754X-4.0	■	■	■				764X-4.0	■	■	■	■	□	■
4.0	8	0.2	754X-4.0-R20	■	■	■				764X-4.0-R20	■	■	■	■	□	■

7XX-XX-B



Sur demande pour serrage type B, voir page 1.03  
 Wahlweise für B-Spannsystem, siehe Seite 1.03  
 On request for B clamping system, see page 1.03

Foncer-tourner

Einstecken und drehen

Grooving and turning

## 754ZX / 764ZX

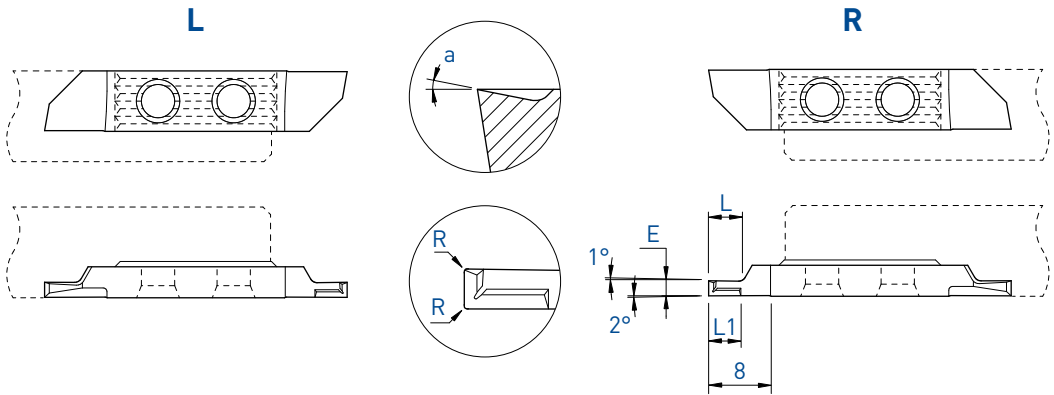

Pour un meilleur contrôle des copeaux  
Für eine bessere Spankontrolle  
For a better chip-control

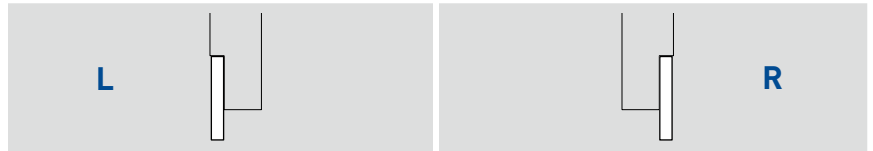

E	L	L1	a	R	Art. N°	TIALN		HTA	HAS	HTIN	HN (µk10)	Art. N°	TIALN		HTA	HAS	HTIN	HN (µk10)
						TiN	N (µk20)						TiN	N (µk20)				
1.5	4	4	10°	0.03	754ZX10-1.5-R03	■	□					764ZX10-1.5-R03	■	■				
1.5	4	4	10°	0.08	754ZX10-1.5-R08	■	□					764ZX10-1.5-R08	■	■				
2.0	4	4	10°	0.08	754ZX10-2.0-R08	■	□					764ZX10-2.0-R08	■	■				
2.0	4	4	10°	0.2	-							764ZX10-2.0-R20	■	□				
2.5	5	5	10°	0.08	754ZX10-2.5-R08	■	■					764ZX10-2.5-R08	■	■				
2.5	5	5	10°	0.2	-							764ZX10-2.5-R20	■	■				
3.0	6	6	10°	0.08	754ZX10-3.0-R08	■	□					764ZX10-3.0-R08	■	■				
3.0	6	6	10°	0.2	-							764ZX10-3.0-R20	■	■				
4.0	6	6	10°	0.2	-							764ZX10-4.0-R20	■	□				
2.0	4	4	25°	0.08	-							764ZX25-2.0-R08			■	■	□	
2.0	4	4	25°	0.2	-							764ZX25-2.0-R20			■	■	□	
2.5	5	5	25°	0.08	-							764ZX25-2.5-R08			■	■	□	
2.5	5	5	25°	0.2	-							764ZX25-2.5-R20			■	■	□	

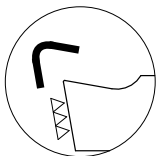

Arête de coupe honée  
Gehonte Schneidkante  
Honed edge

f min: 0.02 mm/U

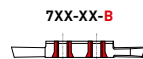

Sur demande pour serrage type B, voir page 1.03  
Wahlweise für B-Spannsystem, siehe Seite 1.03  
On request for B clamping system, see page 1.03

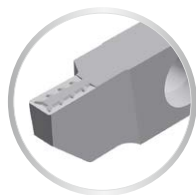
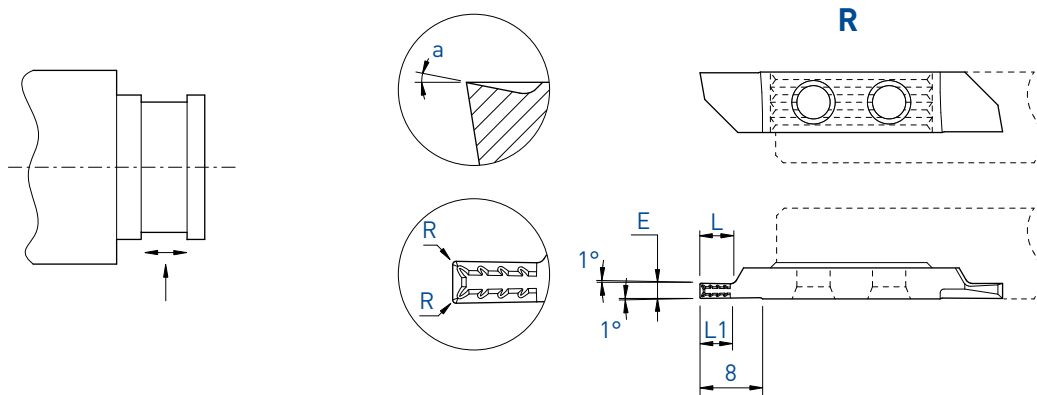

Pour un meilleur contrôle des copeaux  
Für eine bessere Spankontrolle  
For a better chip-control

**NEW**

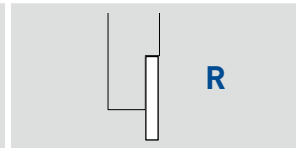
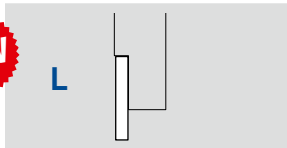

E	L	L1	a	R	Art. N°	TIALN	TiN	N (µm20)	Art. N°	TIALN	TiN	N (µm20)
1.5	4	4	10°	0.03	-				764ZXT10-1.5-R03	■	□	
1.5	4	4	10°	0.08	754ZXT10-1.5-R08	■	□		764ZXT10-1.5-R08	■	□	
2.0	4	4	10°	0.08	754ZXT10-2.0-R08	■	□		764ZXT10-2.0-R08	■	□	
2.0	4	4	10°	0.2	-				764ZXT10-2.0-R20	■	□	
2.5	5	5	10°	0.08	754ZXT10-2.5-R08	■	□		764ZXT10-2.5-R08	■	□	
2.5	5	5	10°	0.2	-				764ZXT10-2.5-R20	■	□	
3.0	6	6	10°	0.08	754ZXT10-3.0-R08	■	□		764ZXT10-3.0-R08	■	□	
3.0	6	6	10°	0.2	-				764ZXT10-3.0-R20	■	□	
3.0	6	6	10°	0.4	-				764ZXT10-3.0-R40	■	□	
4.0	8	8	10°	0.2	-				764ZXT10-4.0-R20	■	□	
4.0	8	8	10°	0.4	-				764ZXT10-4.0-R40	■	□	

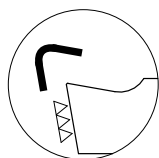

Arête de coupe honée  
Gehonte Schneidkante  
Honed edge

f min: 0.02 mm/U

7XX-XX-B



Sur demande pour serrage type B, voir page 1.03  
Wahlweise für B-Spannsystem, siehe Seite 1.03  
On request for B clamping system, see page 1.03



**Fileter**

**Gewinde drehen**

**Threading**

**756 / 766**

**L**

**R**

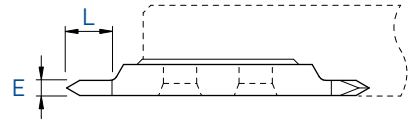
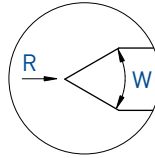
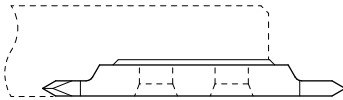
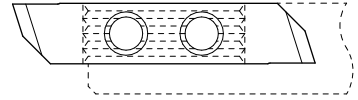
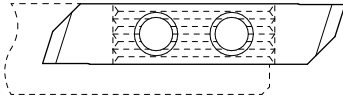

**L**



**R**



W	E	L	R	Art. N°	TiALN	TiN	N (µk20)	HTA	HTiN	HN (µk10)	Art. N°	TiALN	TiN	N (µk20)	HTA	HTiN	HN (µk10)
60°	2.0	6	0	<b>756-60-2</b>	■	■	■				<b>766-60-2</b>	■	■	■			
60°	2.0	6	0.02	<b>756-60-2-R02</b>	■	■	■	■	□	■	<b>766-60-2-R02</b>	■	■	■	■	□	■
60°	3.0	8	0	<b>756-60-3</b>	■	■	■				<b>766-60-3</b>	■	■	■			
60°	3.0	8	0.02	<b>756-60-3-R02</b>	■	■	■	■	□	■	<b>766-60-3-R02</b>	■	■	■	■	□	■
55°	2.0	6	0	<b>756-55-2</b>	■	■	■				<b>766-55-2</b>	■	■	■			
55°	3.0	8	0	<b>756-55-3</b>	■	■	■				<b>766-55-3</b>	■	■	■			

**7XX-XX-B**



Sur demande pour serrage type B, voir page 1.03  
Wahlweise für B-Spannsystem, siehe Seite 1.03  
On request for B clamping system, see page 1.03

# TOP-Line

Fileter

Gewinde drehen

Threading

756-AG60° / 766-AG60°  
756-G60° / 766-G60°

L

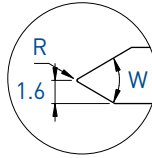
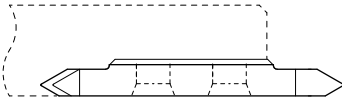
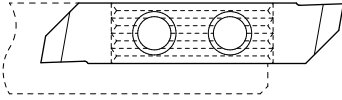

R

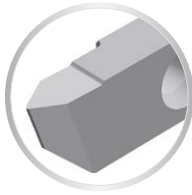
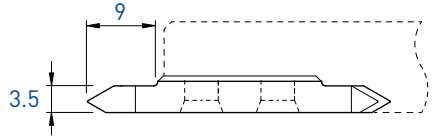
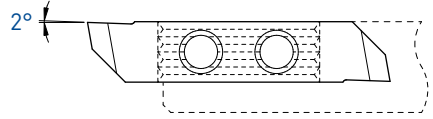

Profil partiel  
Teilprofil  
Partial profile

L

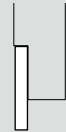

R



W	R	Pas Steigung Pitch P	L				R									
			Art. N°	TiALN	TiN	N (µk20)	HTA	HTiN	HN (µk10)	Art. N°	TiALN	TiN	N (µk20)	HTA	HTiN	HN (µk10)
60°	0.06	0.50-1.50	756-AG60°	■	■	■				766-AG60°	■	■	■			
60°	0.2	1.75-3.00	756-G60°	■	■	■				766-G60°	■	■	■			

7XX-XX-B



Sur demande pour serrage type B, voir page 1.03  
Wahlweise für B-Spannsystem, siehe Seite 1.03  
On request for B clamping system, see page 1.03

**Fileter**

**Gewinde drehen**

**Threading**

**756-M / 766-M**

**L**

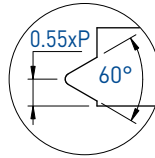
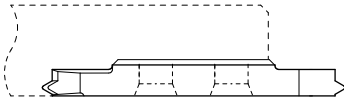
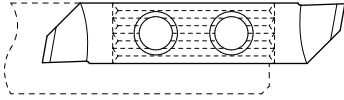

**R**

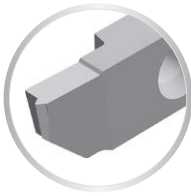
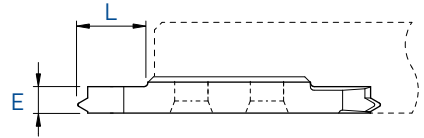
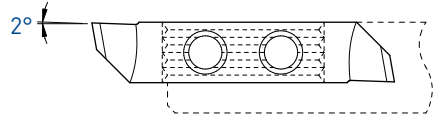

Profil complet métrique  
Vollprofil metrisch  
Full profile metric

**L**

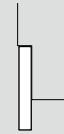

**R**



E	L	Pas Steigung Pitch P	L			R				
			Art. N°	TIALN	TiN	N (µk20)	Art. N°	TIALN	TiN	N (µk20)
2.5	8	0.80	<b>756-M-0.80</b>	■	■	■	<b>766-M-0.80</b>	■	■	■
2.5	8	1.00	<b>756-M-1.00</b>	■	■	■	<b>766-M-1.00</b>	■	■	■
2.5	8	1.25	<b>756-M-1.25</b>	■	■	■	<b>766-M-1.25</b>	■	■	■
3.5	9	1.50	<b>756-M-1.50</b>	■	■	■	<b>766-M-1.50</b>	■	■	■
3.5	9	1.75	<b>756-M-1.75</b>	■	■	■	<b>766-M-1.75</b>	■	■	■
3.5	9	2.00	<b>756-M-2.00</b>	■	■	■	<b>766-M-2.00</b>	■	■	■

Pour de plus petits pas, voir page 1.72  
Für kleinere Steigungen, siehe Seite 1.72  
For smaller pitches, see page 1.72

**7XX-XX-B**



Sur demande pour serrage type B, voir page 1.03  
Wahlweise für B-Spannsystem, siehe Seite 1.03  
On request for B clamping system, see page 1.03

■ = disponible / verfügbar / available  
□ = selon disponibilité du stock / jenach Lagerverfügbarkeit / depending on stock availability

# TOP-Line

Plaquettes à rayon  
 Radius-Wendeplatten  
 Inserts with radius

757 / 767

L

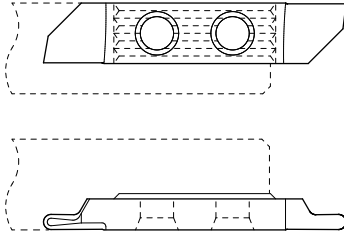

R

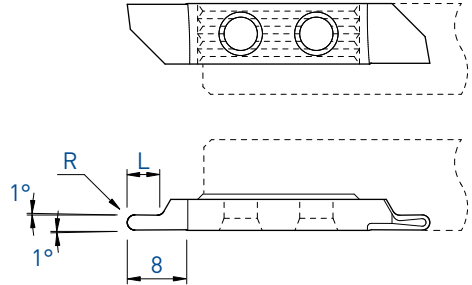

L

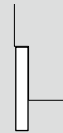

R



R	L	Art. N°	TiALN	TiN	N (µk20)	HTA	HTiN	HN (µk10)	Art. N°	TiALN	TiN	N (µk20)	HTA	HTiN	HN (µk10)
0.5	2.5	757-R0.5	■	■	■				767-R0.5	■	■	■			
1.0	4	757-R1.0	■	■	■				767-R1.0	■	■	■			
1.5	6	757-R1.5	■	■	■				767-R1.5	■	■	■			
2.0	8	757-R2.0	■	■	■				767-R2.0	■	■	■			

7XX-XX-B



Sur demande pour serrage type B, voir page 1.03  
 Wahlweise für B-Spannsystem, siehe Seite 1.03  
 On request for B clamping system, see page 1.03

Plaquettes à rayon  
 Radius-Wendeplatten  
 Inserts with radius

## 757ZX10 / 767ZX10

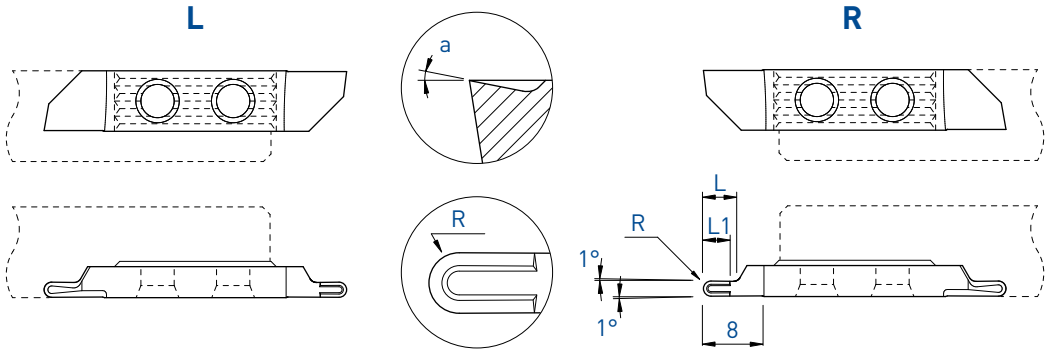

Pour un meilleur contrôle des copeaux  
 Für eine bessere Spankontrolle  
 For a better chip-control

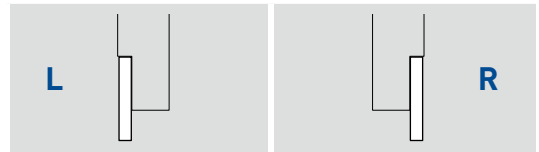

R	L	L1	a	Art. N°	TiALN	TiN	N (µk20)	Art. N°	TiALN	TiN	N (µk20)
1.0	4	3.5	10°	757ZX10-R1.0	■	□		767ZX10-R1.0	■	□	
1.5	6	4.0	10°	757ZX10-R1.5	■	□		767ZX10-R1.5	■	□	
2.0	8	4.5	10°	757ZX10-R2.0	■	□		767ZX10-R2.0	■	□	

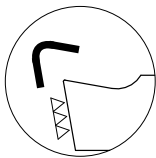

Arête de coupe honée  
 Gehonte Schneidkante  
 Honed edge

f min: 0.02 mm/U

7XX-XX-B



Sur demande pour serrage type B, voir page 1.03  
 Wahlweise für B-Spannsystem, siehe Seite 1.03  
 On request for B clamping system, see page 1.03

# TOP-Line

Plaquette ébauché

WSP-Rohling

Blank insert

**751-E / 761-E**  
**751-EP / 761-EP**

**L**

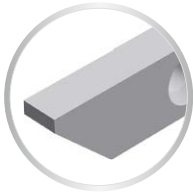
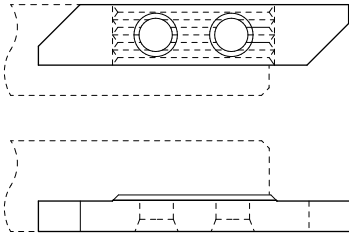

**7XX-XX-B**



Sur demande pour serrage type B, voir page 1.03  
Wahlweise für B-Spannsystem, siehe Seite 1.03  
On request for B clamping system, see page 1.03

**R**

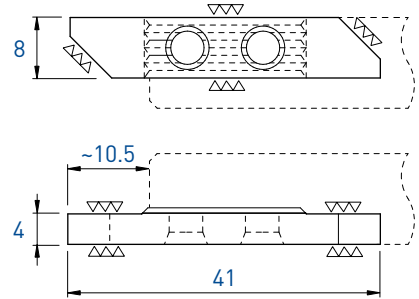

<b>L</b>		<b>R</b>			
Art. N°	N (µk20)	HN (µk10)	Art. N°	N (µk20)	HN (µk10)
751-E	■	■	761-E	■	■

**L**

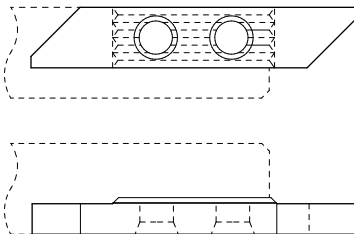

Face de coupe polie  
Polierte Schneidfläche  
Cutting face polished

**R**

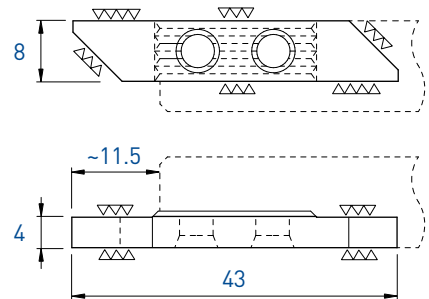

<b>L</b>		<b>R</b>											
Art. N°	TiALN	TiN	N (µk20)	HTA	HTiN	HN (µk10)	Art. N°	TiALN	TiN	N (µk20)	HTA	HTiN	HN (µk10)
751-EP	■	■	■	□	□	■	761-EP	■	■	■	■	□	■

**770 / 780**

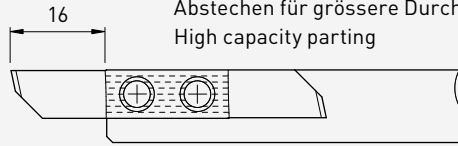

Tronçonnage de grande capacité  
Abstechen für grössere Durchmesser  
High capacity parting

> **1.130**

**7050 / 7060**

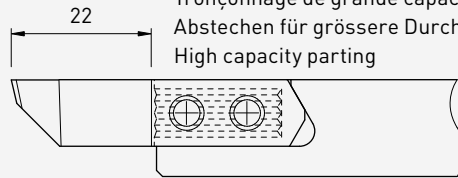

Tronçonnage de grande capacité  
Abstechen für grössere Durchmesser  
High capacity parting

> **1.140**

**W750 / W760**

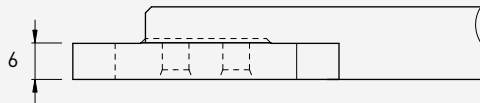

Outil avec plaquettes ébauchées larges pour profilage  
Werkzeug mit breiten WSP-Rohlingen für Profilschleifen  
Tool with wide blank inserts for profiling

> **1.146**

**740Z / 760Z**

Porte-outils pour usinage déporté  
Halter für versetzte Bearbeitung  
Holders for shifted machining

> **1.150**

**CAPTO C3 / C4**

> **1.151**

**Tornos DECO 7/10 R**

Pour machines avec rotation à droite  
Für rechts drehende Maschinen  
For right hand turning machines

> **1.152**

**Tornos DECO 7/10 L**

Pour machines avec rotation à gauche  
Für links drehende Maschinen  
For left hand turning machines

> **1.154**

**Tornos DECO 13 / DECO20**

> **1.156**

**Tornos MULTISWISS**

> **1.158**

**Tornos AS14 / SAS16**

> **1.159**

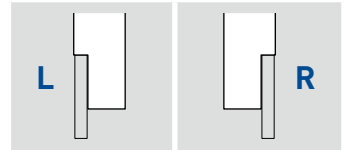
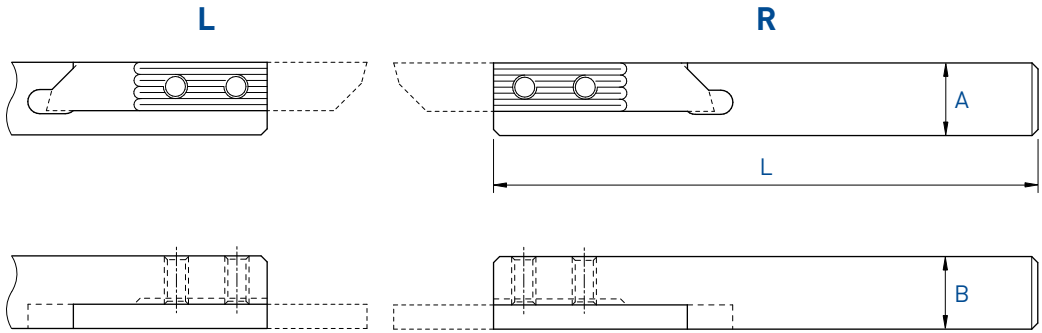

A x B	L	Serrage Spannsystem Clamping	Art. N°	Art. N°
12 x 12	130	A	<b>770-12</b>	<b>780-12</b>
12 x 12	90	A	<b>770-12-90</b>	<b>780-12-90</b>
12.7 x 12.7	130	A	<b>770-12.7</b>	<b>780-12.7</b>
14 x 14	130	A	<b>770-14</b>	<b>780-14</b>
16 x 16	130	A	<b>770-16</b>	<b>780-16</b>
16 x 16	75	A	<b>770-16-75</b>	<b>780-16-75</b>
20 x 20	120	A	<b>770-20</b>	<b>780-20</b>
25 x 25	140	A	<b>770-25</b>	<b>780-25</b>

Chaque support est livré avec vis et clé.  
 Jeder Halter wird mit Spannschraube(n) und Schlüssel geliefert.  
 Screw(s) and key are included with each tool holder.



Porte-outils

Coupe déportée

Halter

Versetztes Schneiden

Holder

Cut off line

## 770RC

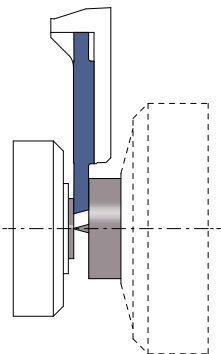
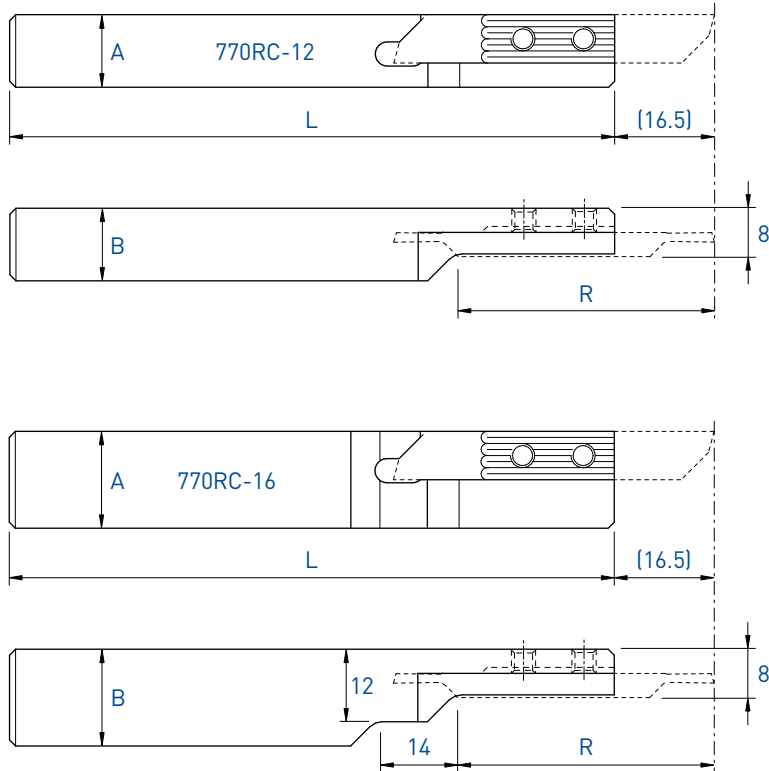

Utiliser des plaquettes type 771R  
WSP Typ 771R verwenden  
Use inserts type 771R

Voir pages 1.134 - 1.137  
Siehe Seiten 1.134 - 1.137  
See pages 1.134 - 1.137

**NEW**

**L (R)**

Coupe à droite déportée  
Versetztes Rechtsschneiden  
Right cut off line

A x B	L	R	Serrage Spannsystem Clamping	Art. N°
12 x 12	130	42	A	<b>770RC-12</b>
16 x 16	130	42	A	<b>770RC-16</b>

Chaque support est livré avec vis et clé.  
Jeder Halter wird mit Spannschraube(n) und Schlüssel geliefert.  
Screw(s) and key are included with each tool holder.

L

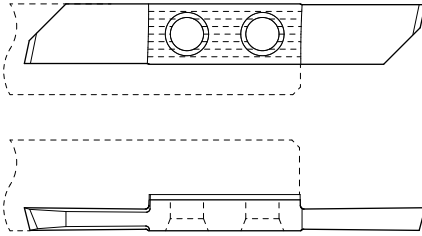

R

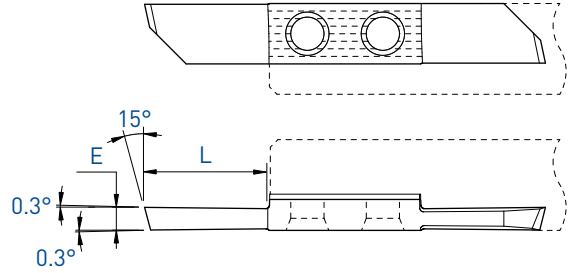

L

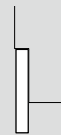

R



E	L	Art. N°				Art. N°			
			TiAlN	TiN	N (µk20)		TiAlN	TiN	N (µk20)
1.5	16	-				781-1.5	■	□	■
2.0	16	771-2.0	■	■	■	781-2.0	■	■	■
2.5	16	771-2.5	■	■	■	781-2.5	■	■	■
3.0	16	771-3.0	■	■	■	781-3.0	■	■	■
3.5	16	771-3.5	■	■	■	781-3.5	■	■	■

Tronçonnage

Abstechen

Parting off

## 771XF / 781XF

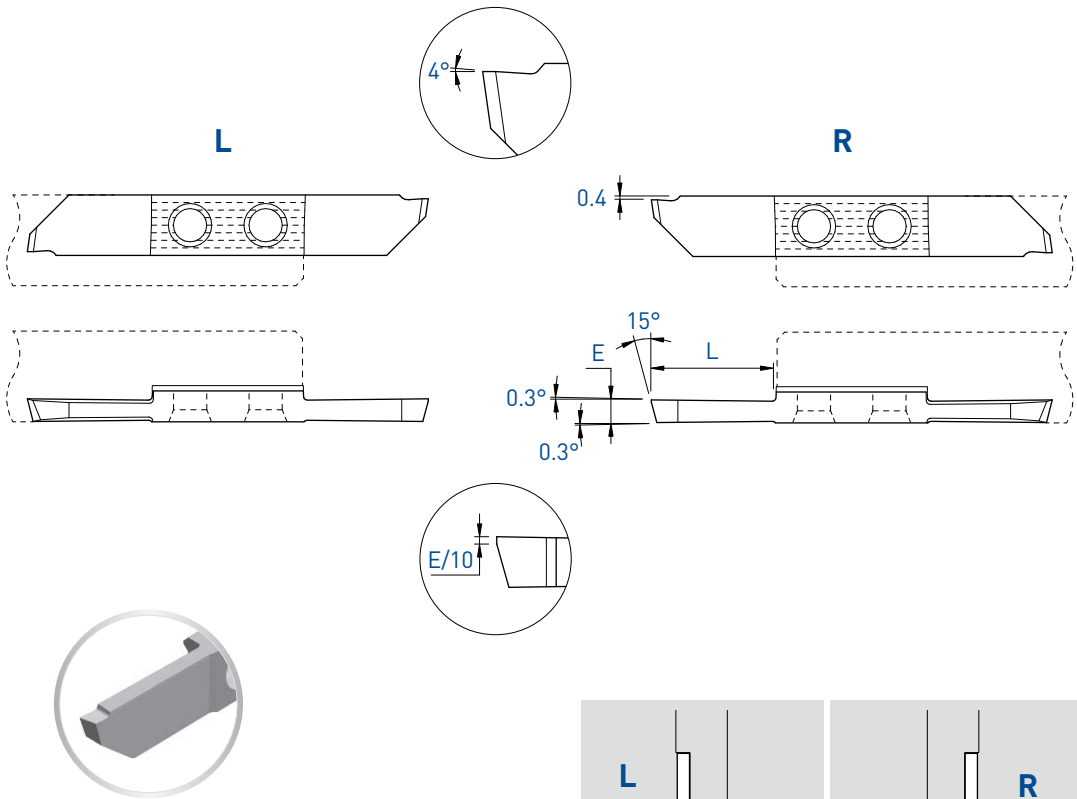

		L			R				
E	L	Art. N°	TiAlN	TiN	N (µk20)	Art. N°	TiAlN	TiN	N (µk20)
2.0	16	-				781XF-2.0	■	■	■
2.5	16	771XF-2.5	■	■	■	781XF-2.5	■	■	■
3.0	16	771XF-3.0	■	■	■	781XF-3.0	■	■	■
3.5	16	771XF-3.5	■	■	■	781XF-3.5	■	■	■

Tronçonnage

Abstechen

Parting off

Coupe déportée

Versetztes Schneiden

Cut off line

771R

## Cut R

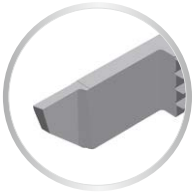
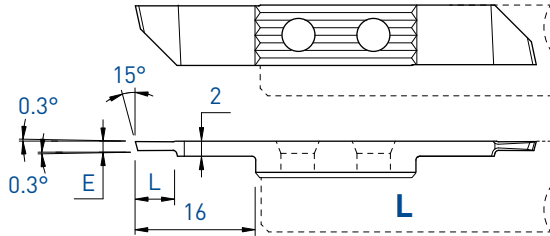

## L (R)

Coupe à droite déportée  
Versetztes Rechtsschneiden  
Right cut off line

E	L	Art. N°	TiALN	TiN	N (µm20)
1.0	5	771R-1.0	■	■	■
1.2	5	771R-1.2	■	■	■
1.5	8.5	771R-1.5	■	■	■

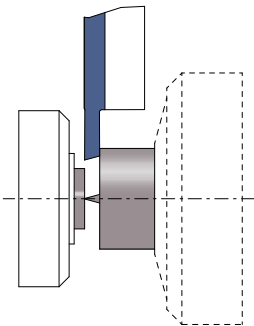

Tronçonnage

Coupe déportée

Abstechen

Versetztes Schneiden

Parting off

Cut off line

781L / 771R

Cut L

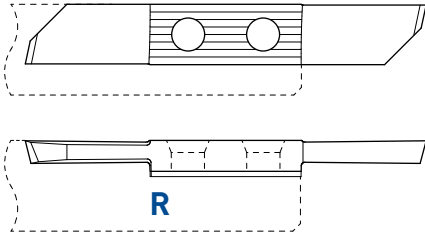

Cut R

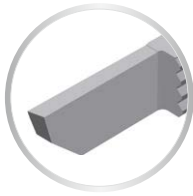
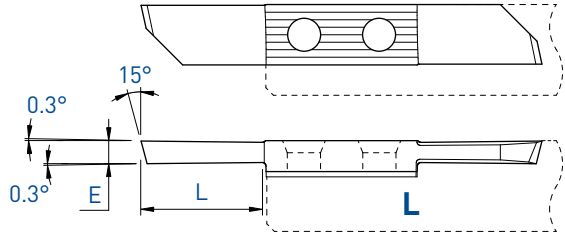

R (L)

Coupe à gauche déportée  
Versetztes Linksschneiden  
Left cut off line

L (R)

Coupe à droite déportée  
Versetztes Rechtsschneiden  
Right cut off line

E	L	Art. N°	TiAlN			Art. N°	TiN		
			Ti	N	(µk20)		Ti	N	(µk20)
2.0	16	781L-2.0	■	■	■	771R-2.0	■	■	■
2.5	16	781L-2.5	■	■	■	771R-2.5	■	■	■
3.0	16	781L-3.0	■	■	■	771R-3.0	■	■	■
3.5	16	781L-3.5	■	■	■	771R-3.5	■	■	■

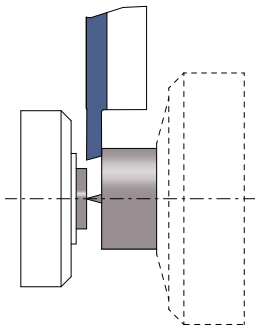

Tronçonnage

Abstechen

Parting off

Coupe déportée

Versetztes Schneiden

Cut off line

## 781LXF / 771RXF

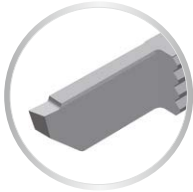
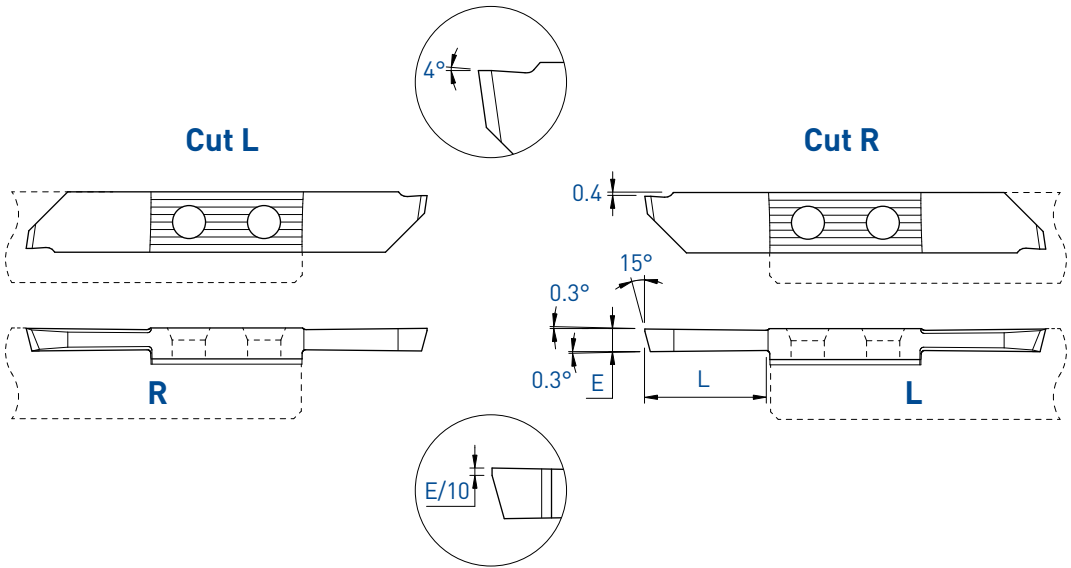

**R (L)**

Coupe à gauche déportée  
Versetztes Linksschneiden  
Left cut off line

**L (R)**

Coupe à droite déportée  
Versetztes Rechtsschneiden  
Right cut off line

E	L	Art. N°	R (L)			Art. N°	L (R)		
			TiAlN	TiN	N (µk20)		TiAlN	TiN	N (µk20)
2.0	16	-				771RXF-2.0	■	■	■
2.5	16	781LXF-2.5	■	■	■	771RXF-2.5	■	■	■
3.0	16	781LXF-3.0	■	■	■	771RXF-3.0	■	■	■
3.5	16	781LXF-3.5	■	■	■	771RXF-3.5	■	■	■

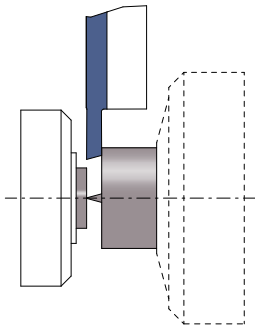

Tronçonnage

Coupe déportée

Abstechen

Versetztes Schneiden

Parting off

Cut off line

771RD

## Cut R

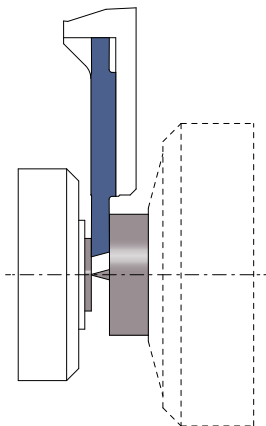
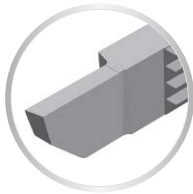
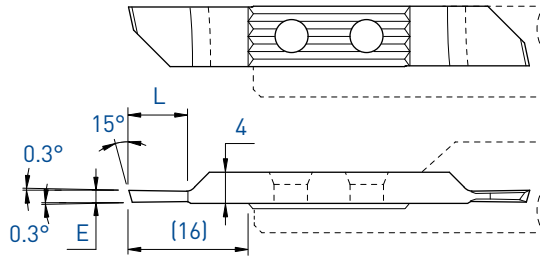

## L (R)

Coupe à droite déportée  
Versetztes Rechtsschneiden  
Right cut off line

E	L	Art. N°	TiAlN	TiN	N (µk20)
1.2	5	771RD-1.2	■	■	■
1.5	7.5	771RD-1.5	■	■	■
2.0	10	771RD-2.0	■	■	■

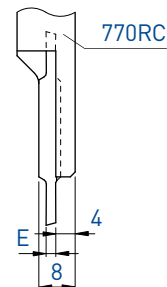

# TOP-Line

Plaquette ébauche

WSP-Rohling

Blank insert

771-E / 781-E

L

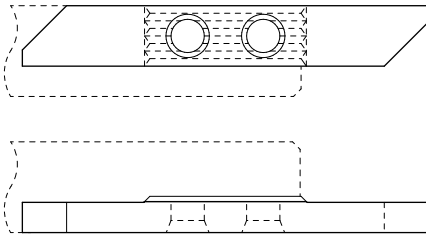

R

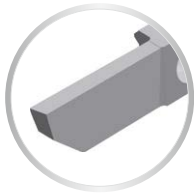
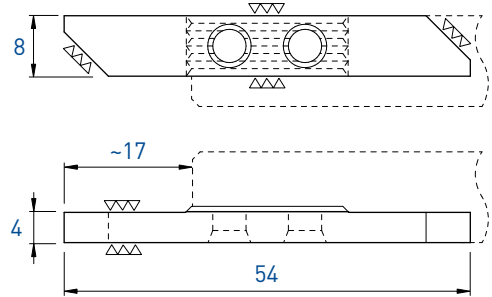

L		R	
Art. N°	Z (µk20)	Art. N°	Z (µk20)
771-E	■	781-E	■



**OUTILS DE HAUTES PERFORMANCES  
POUR LE DÉCOLLETAGE  
ET LA MICROMÉCANIQUE**

**HOCHLEISTUNGSWERKZEUGE  
FÜR DREHAUTOMATEN  
UND MIKROMECHANIK**

**HIGH PERFORMANCE TOOLING  
FOR AUTOMATIC LATHES  
AND MICROMECHANICS**



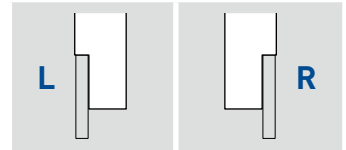
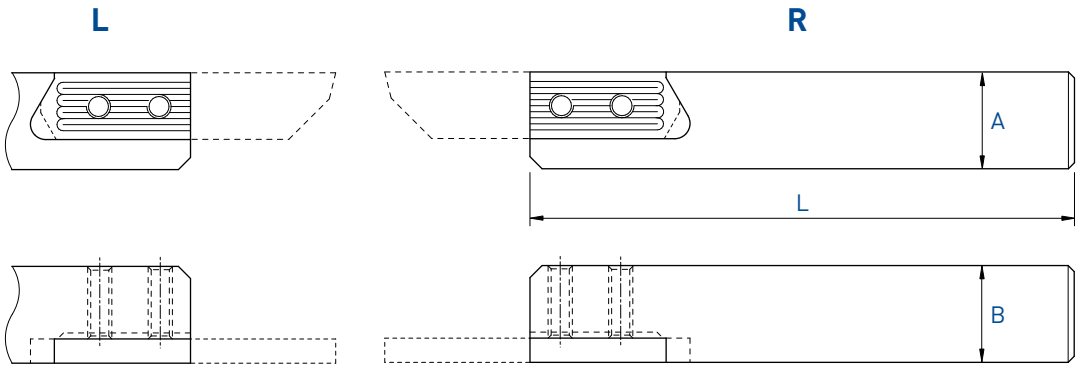

A x B	L	Serrage Spannsystem Clamping	Art. N°	Art. N°
16 x 16	130	A	<b>7050-16</b>	<b>7060-16</b>
16 x 16	75	A	<b>7050-16-75</b>	<b>7060-16-75</b>
20 x 20	120	A	<b>7050-20</b>	<b>7060-20</b>
25 x 25	140	A	<b>7050-25</b>	<b>7060-25</b>

Chaque support est livré avec vis et clé.  
 Jeder Halter wird mit Spannschraube(n) und Schlüssel geliefert.  
 Screw(s) and key are included with each tool holder.

Tronçonnage

Abstechen

Parting off

7051 / 7061

L

R

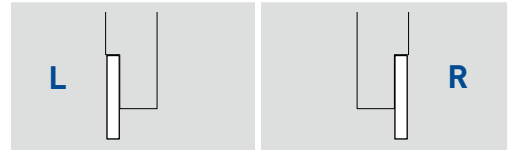
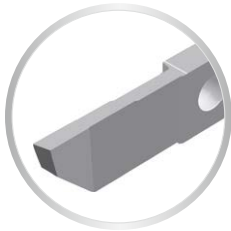
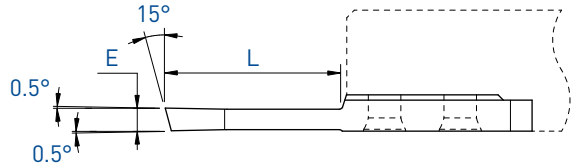
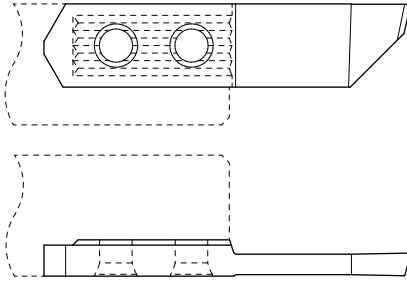

E	L	Art. N°	L			R			
			TiAlN	TiN	N (µk20)	TiAlN	TiN	N (µk20)	
2.5	22	-				7061-2.5	■	■	■
3.0	22	7051-3.0	■	■	■	7061-3.0	■	■	■
3.5	22	-				7061-3.5	■	■	■

# TOP-Line

Tronçonnage

Abstechen

Parting off

7051XF / 7061XF

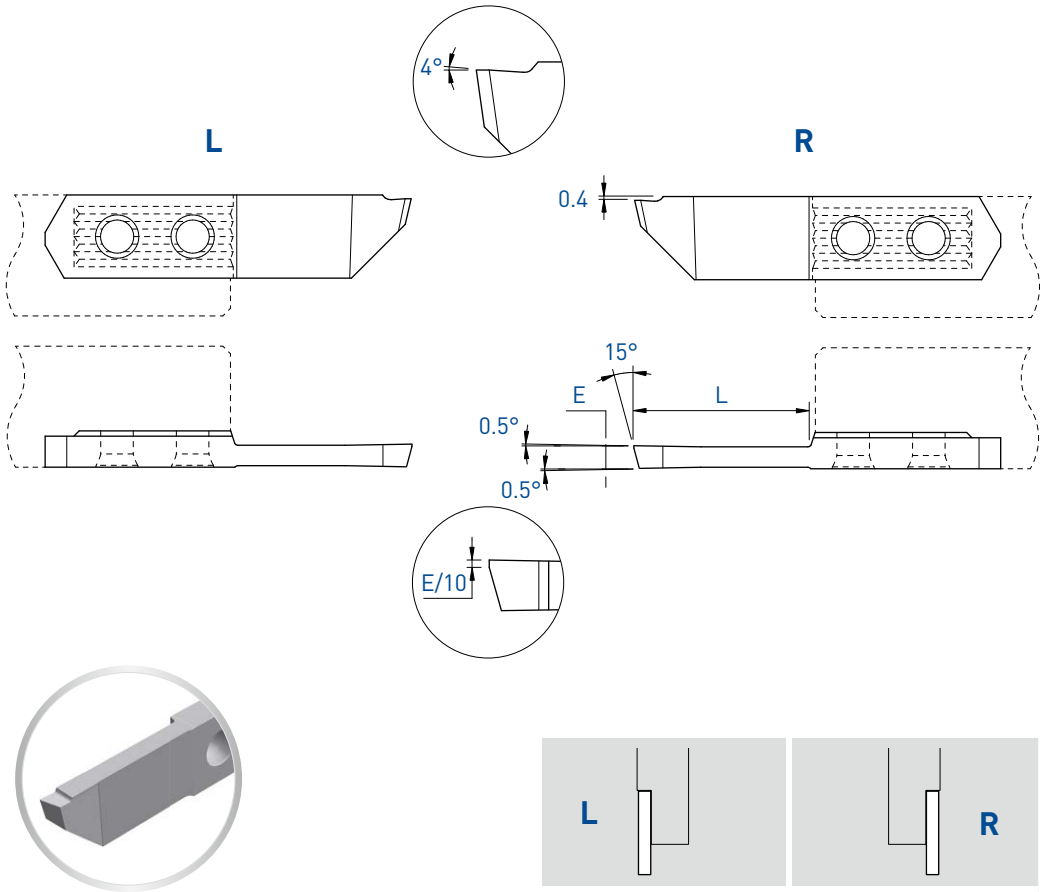

		L			R				
E	L	Art. N°	TiAlN	TiN	N (µk20)	Art. N°	TiAlN	TiN	N (µk20)
3.0	22	7051XF-3.0	■	■	■	7061XF-3.0	■	■	■

Tronçonnage

Coupe déportée

Abstechen

Versetztes Schneiden

Parting off

Cut off line

7061L / 7051R

Cut L

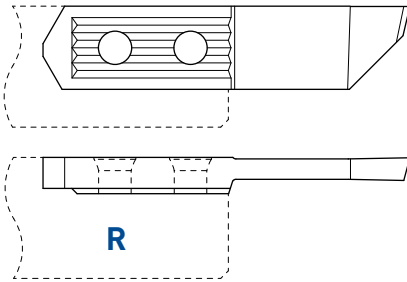

Cut R

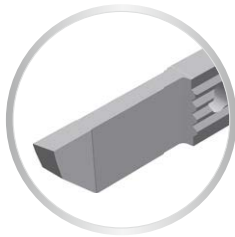
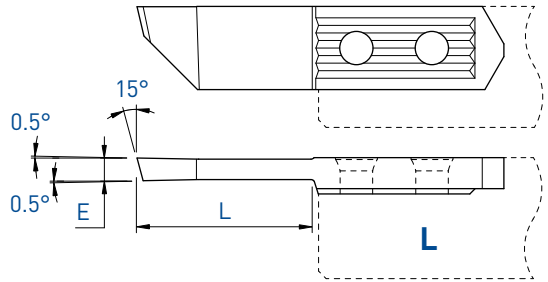

R (L)

Coupe à gauche déportée  
Versetztes Linksschneiden  
Left cut off line

L (R)

Coupe à droite déportée  
Versetztes Rechtsschneiden  
Right cut off line

E	L	Art. N°	TiAlN	TiN	N (µk20)	Art. N°	TiAlN	TiN	N (µk20)
2.5	22	-				7051R-2.5	■	■	■
3.0	22	7061L-3.0	■	■	■	7051R-3.0	■	■	■
3.5	22	-				7051R-3.5	■	■	■

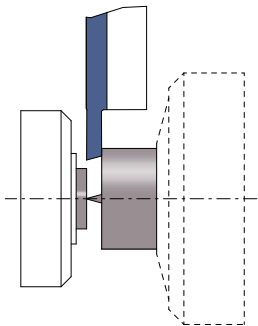

# TOP-Line

Tronçonnage

Abstechen

Parting off

Coupe déportée

Versetztes Schneiden

Cut off line

7061LXF / 7051RXF

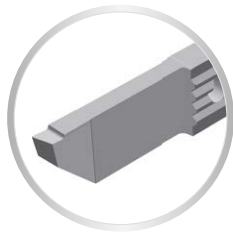
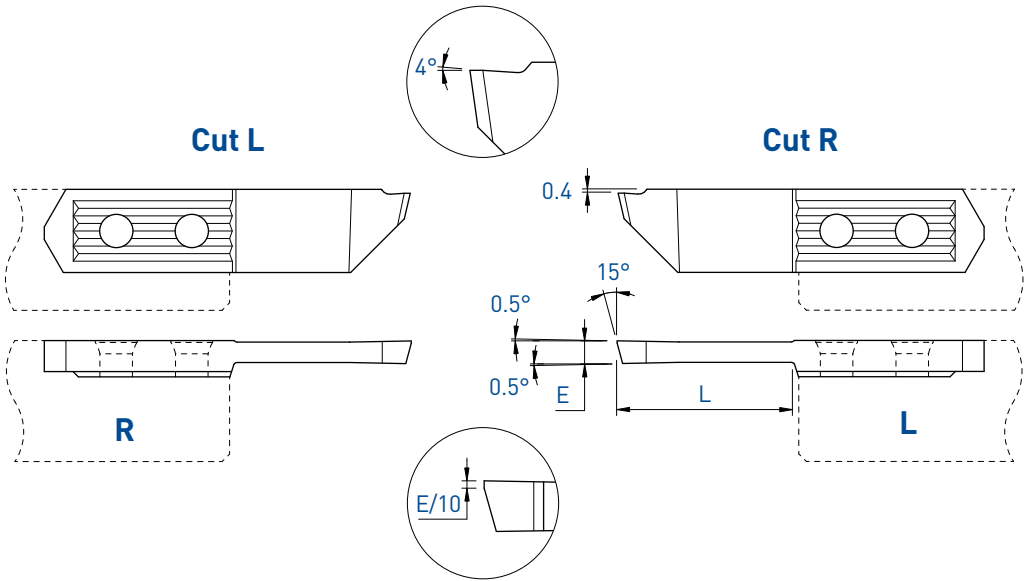

**R (L)**

Coupe à gauche déportée  
Versetztes Linksschneiden  
Left cut off line

**L (R)**

Coupe à droite déportée  
Versetztes Rechtsschneiden  
Right cut off line

E	L	Art. N°	TiAlN	TiN	N [µk20]	Art. N°	TiAlN	TiN	N [µk20]
3.0	22	7061LXF-3.0	■	■	■	7051RXF-3.0	■	■	■

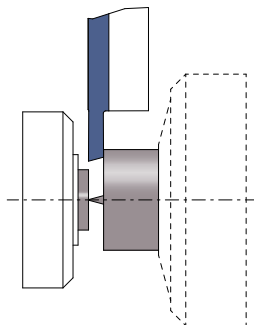

Plaquette ébauche

WSP-Rohling

Blank insert

7051-E / 7061-E

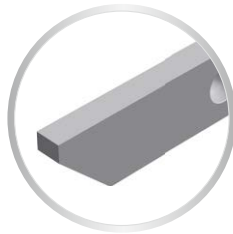
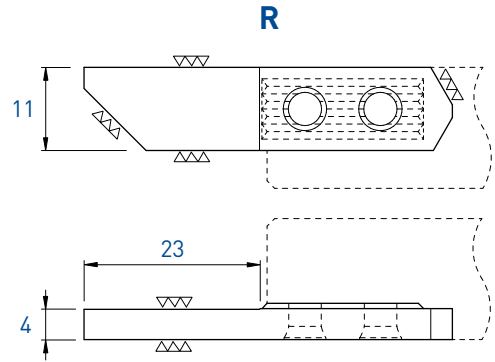
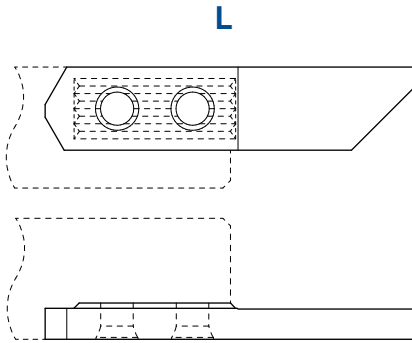

<b>L</b>		<b>R</b>	
Art. N°	N [μk20]	Art. N°	N [μk20]
7051-E	■	7061-E	■

L

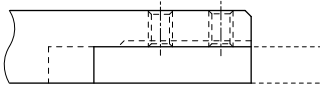
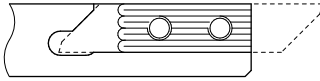

R

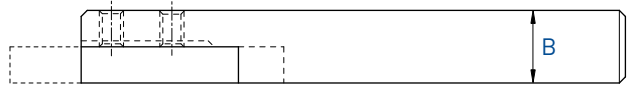
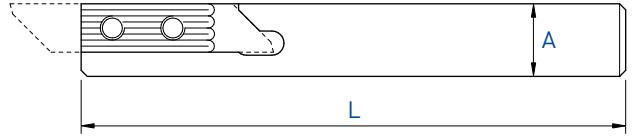

L



R

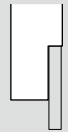

A x B	L	Serrage Spannsystem Clamping	Art. N°	Art. N°
12 x 12	130	A	<b>W750-12</b>	<b>W760-12</b>
16 x 16	130	A	<b>W750-16</b>	<b>W760-16</b>
20 x 20	120	A	<b>W750-20</b>	<b>W760-20</b>

Chaque support est livré avec vis et clé.  
Jeder Halter wird mit Spannschraube(n) und Schlüssel geliefert.  
Screw(s) and key are included with each tool holder.



Porte-outils avec arrosage intégré

Halter mit integriertem Kühlmittelzufuhr

Holder with integrated coolant supply

## W750-JET / W760-JET

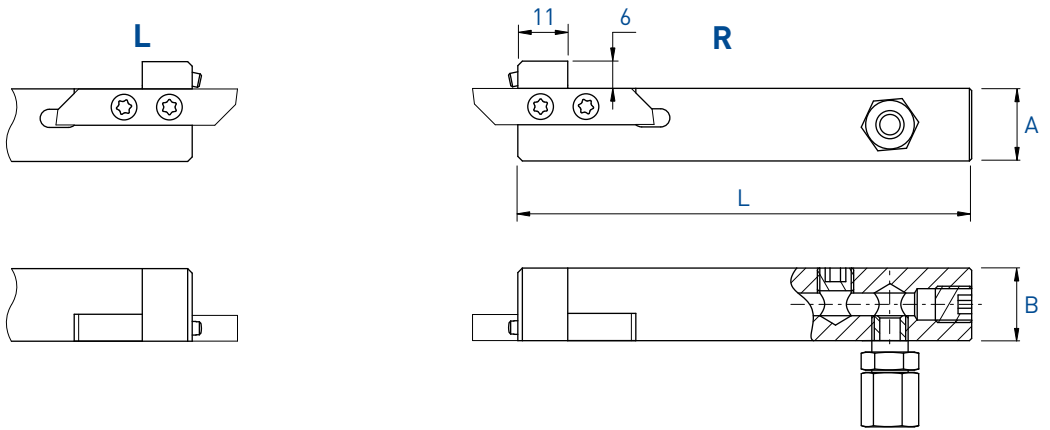

**NEW**

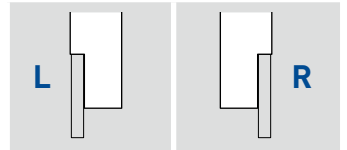

A x B	L	Serrage Spannsystem Clamping	Art. N°	Art. N°
16 x 16	100	A	<b>W750-16-JET</b>	<b>W760-16-JET</b>
20 x 20	100	A	<b>W750-20-JET</b>	<b>W760-20-JET</b>

Pièces de rechange  
Ersatzteile  
Spare parts



Art. N°



Art. N°

Buse  
Düse  
Nozzle



Art. N°

Chaque support est livré avec vis et clé.

Jeder Halter wird mit Spannschraube(n) und Schlüssel geliefert.

Screw(s) and key are included with each tool holder.

W750-JET / W760-JET

**J-M8X1-D6**

**JB-M8X1**

**JJ-M3X6-D1.5**

# TOP-Line

Plaquette ébauche

WSP-Rohling

Blank insert

W751-E5 / W761-E5

L

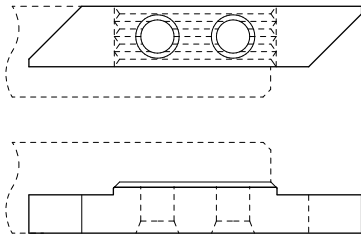

R

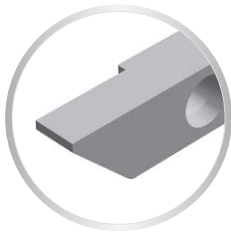
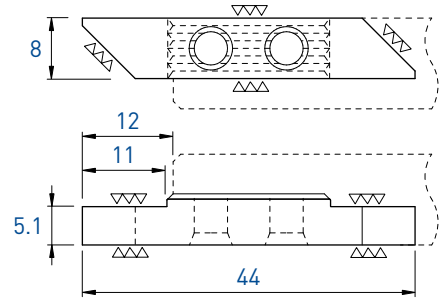

L		R	
Art. N°	N (µm20)	Art. N°	N (µm20)
W751-E5	■	W761-E5	■

Plaquette ébauche

WSP-Rohling

Blank insert

## W751-E6 / W761-E6

L

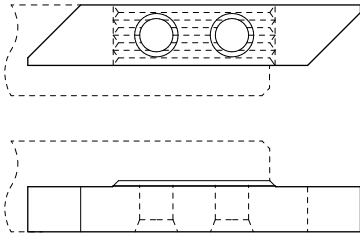

R

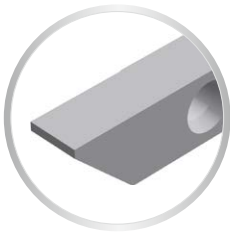
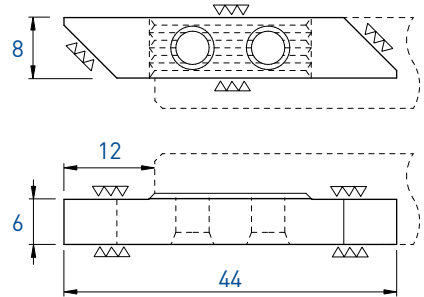

L		R	
Art. N°	N (μk20)	Art. N°	N (μk20)
W751-E6	■	W761-E6	■

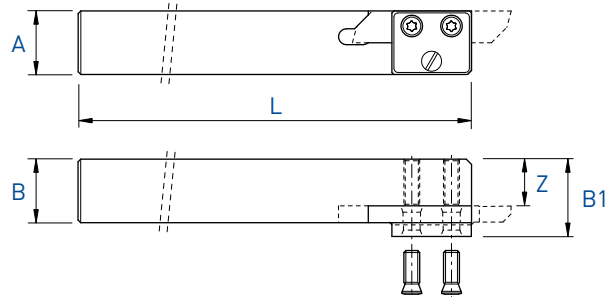
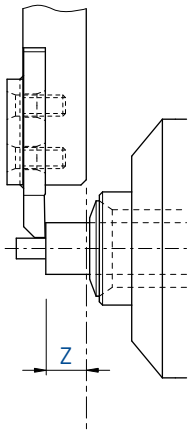

## 740 Series

A x B	L	Z	B1	Art. N°	Plaquettes type... WSP-Typ... Inserts type...	Pages Seiten Pages
12 x 12	130	9.5	14.5	<b>740Z-12</b>	741 - 747	> 1.33
16 x 16	130	13.5	18.5	<b>740Z-16</b>	741 - 747	> 1.33

## 760 Series

A x B	L	Z	B1	Art. N°	Plaquettes type... WSP-Typ... Inserts type...	Pages Seiten Pages
12 x 12	130	8	15	<b>760Z-12</b>	761 - 767	> 1.77
16 x 16	130	12	19	<b>760Z-16</b>	761 - 767	> 1.77

Chaque support est livré avec vis et clé.  
Jeder Halter wird mit Spannschraube(n) und Schlüssel geliefert.  
Screw(s) and key are included with each tool holder.

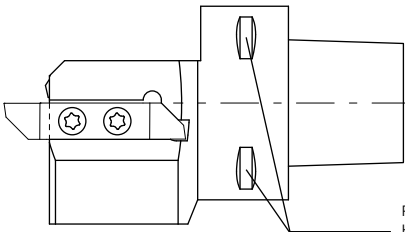
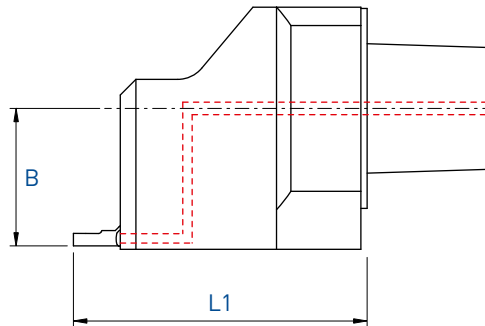
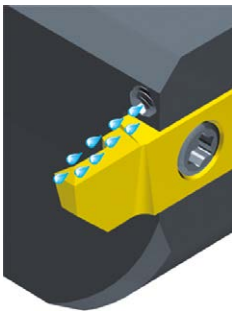
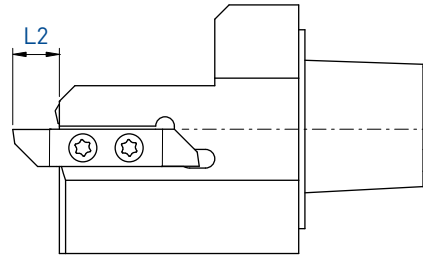
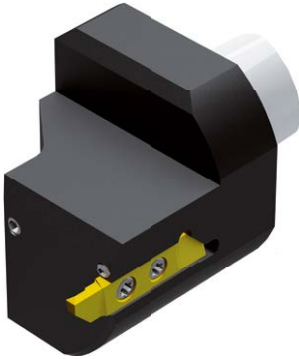

Porte-outils pour changeur automatique sur demande.  
Halter für Werkzeugwechsler auf Anfrage.  
Holders for tool changer on request.

**NEW**

CAPTO	Plaquettes type... WSP-Typ... Inserts type...	Pages Seiten Pages	L1	B	L2	Art. N°	Buse Düse Nozzle 
							Art. N°
C3	741 - 747	> 1.33	47	22	7.5	<b>C3-740-22047</b>	<b>JJ-M3X6-D1.5</b>
C4	761 - 767	> 1.77	62	27	10	<b>C4-760-27062</b>	<b>JJ-M3X6-D1.5</b>

Chaque support est livré avec vis et clé.  
Jeder Halter wird mit Spannschraube(n) und Schlüssel geliefert.  
Screw(s) and key are included with each tool holder.

Porte-outils spéciaux pour machine Tornos DECO 7/10 mm

Sonderhalter für Tornos DECO 7/10 mm Maschine

R DECO 7/10

Special holders für Tornos DECO 7/10 mm machine

Coupe à droite  
Rechtsschneiden  
Right hand cut

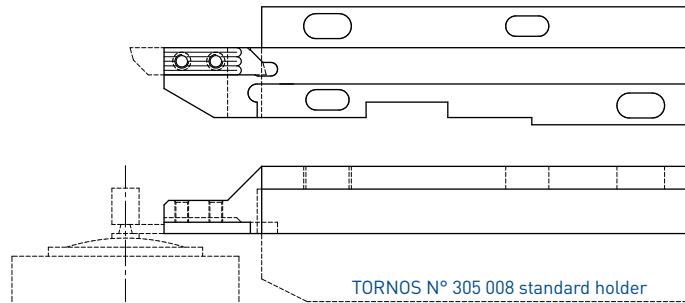

Art. N°	Plaquettes type... WSP-Typ... Inserts type...	Pages Seiten Pages
740-DECO10	741 - 747	> 1.33

Coupe à droite déportée  
Versetztes Rechtsschneiden  
Right cut off line

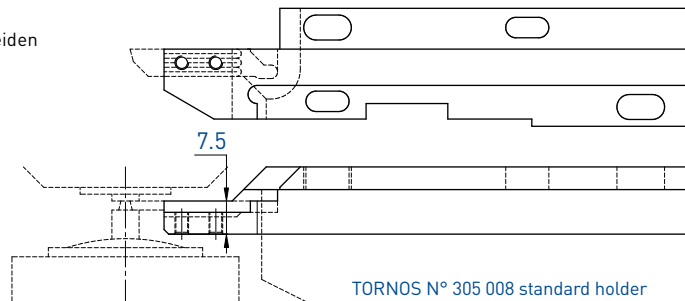

Art. N°	Plaquettes type... WSP-Typ... Inserts type...	Pages Seiten Pages
730R-DECO10	731R / 731N	1.47 - 1.53

Chaque support est livré avec vis et clé.  
Jeder Halter wird mit Spannschraube(n) und Schlüssel geliefert.  
Screw(s) and key are included with each tool holder.

Porte-outils spéciaux pour machine Tornos DECO 7/10 mm

Sonderhalter für Tornos DECO 7/10 mm Maschine

Special holders für Tornos DECO 7/10 mm machine

R DECO 7/10

Pour le tronçonnage de petites pièces  
Zum Abstechen von kleinen Werkstücken  
For small parts parting off



Réglable en longueur  
Längseinstellbar  
Adjustable length

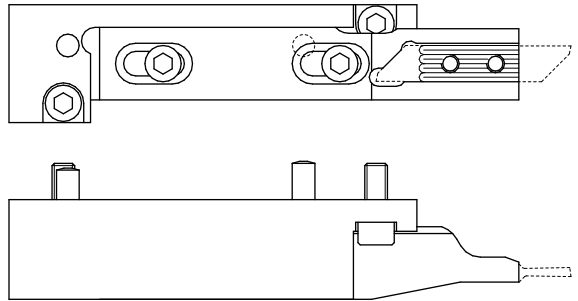

Art. N°	Plaquettes type... WSP-Typ... Inserts type...	Pages Seiten Pages
750R-DECO10	751R / 751N	1.93 - 1.103

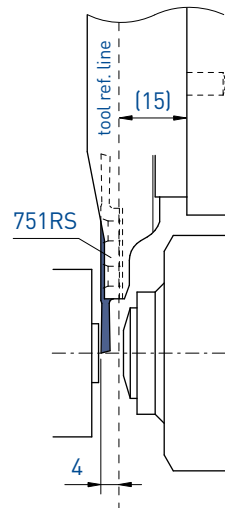
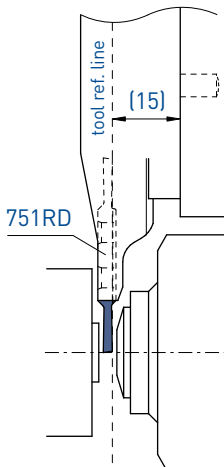

Chaque support est livré avec vis et clé.  
Jeder Halter wird mit Spannschraube(n) und Schlüssel geliefert.  
Screw(s) and key are included with each tool holder.

Porte-outils spéciaux pour machine Tornos DECO 7/10 mm

Sonderhalter für Tornos DECO 7/10 mm Maschine

Special holders für Tornos DECO 7/10 mm machine

**L DECO 7/10**

Coupe à gauche  
Linksschneiden  
Left hand cut

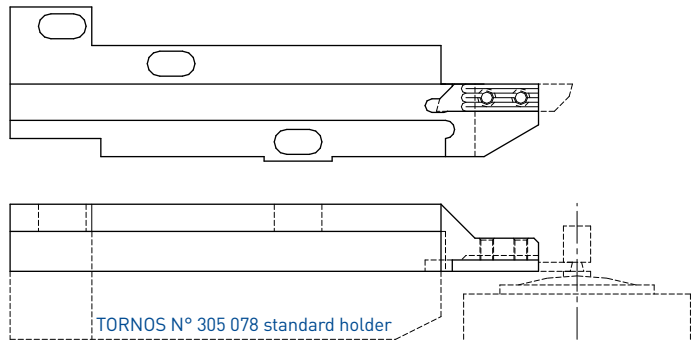

Art. N°	Plaquettes type... WSP-Typ... Inserts type...	Pages Seiten Pages
<b>730-DECO10</b>	731 - 737	> 1.33

Coupe à gauche déportée  
Versetztes Linksschneiden  
Left cut off line

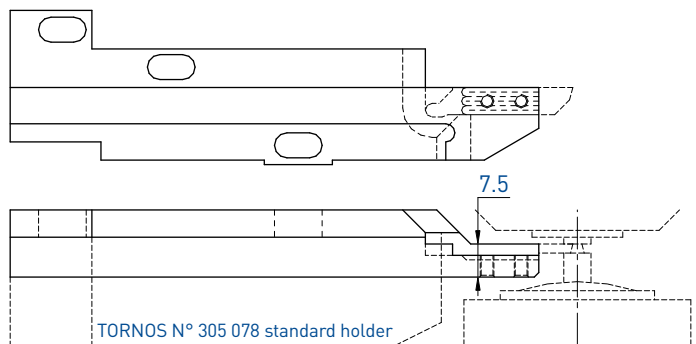

Art. N°	Plaquettes type... WSP-Typ... Inserts type...	Pages Seiten Pages
<b>740L-DECO10</b>	741L / 741N	1.47 - 1.53

Chaque support est livré avec vis et clé.  
Jeder Halter wird mit Spannschraub(en) und Schlüssel geliefert.  
Screw(s) and key are included with each tool holder.



Porte-outils spéciaux pour machine Tornos DECO 7/10 mm

Sonderhalter für Tornos DECO 7/10 mm Maschine

Special holders für Tornos DECO 7/10 mm machine

L DECO 7/10

Pour le tronçonnage de petites pièces  
Zum Abstechen von kleinen Werkstücken  
For small parts parting off

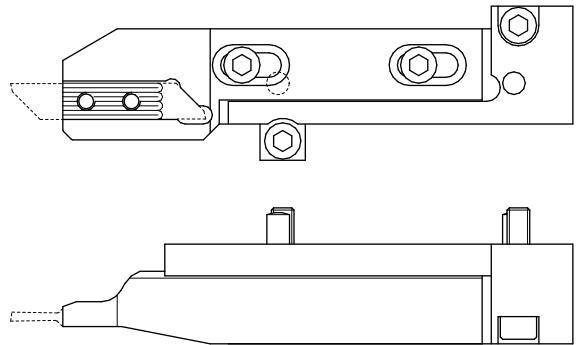

Réglable en longueur  
Längseinstellbar  
Adjustable length

Art. N°	Plaquettes type... WSP-Typ... Inserts type...	Pages Seiten Pages
760L-DECO10	761L / 761N	1.93 - 1.102

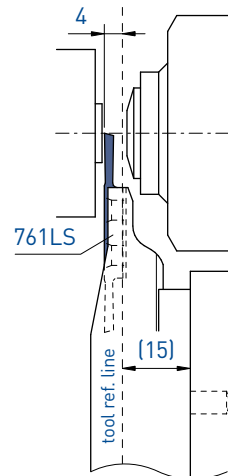
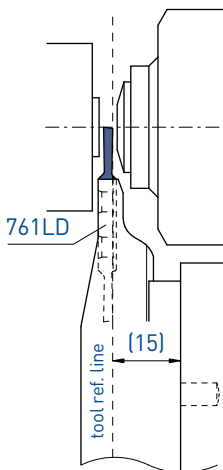

Chaque support est livré avec vis et clé.  
Jeder Halter wird mit Spannschraubel(n) und Schlüssel geliefert.  
Screw(s) and key are included with each tool holder.

Pour le tronçonnage de petites pièces  
Zum Abstechen von kleinen Werkstücken  
For small parts parting off

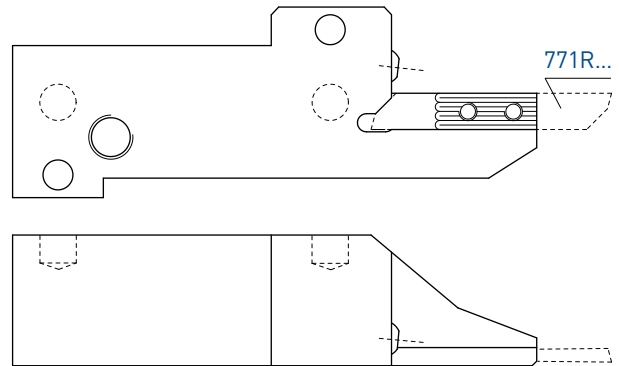

Art. N°	Plaquette type... WSP-Typ... Insert type...	Pages Seiten Pages
770R-DECO13	771R	1.134 - 1.137

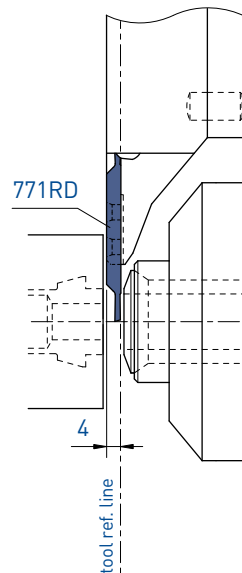
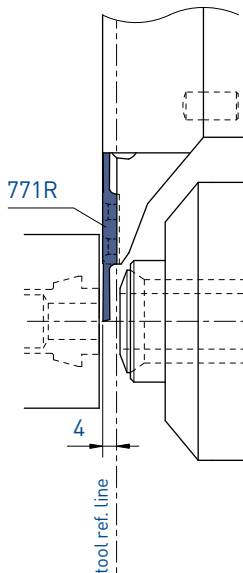

Chaque support est livré avec vis et clé.  
Jeder Halter wird mit Spannschraube(n) und Schlüssel geliefert.  
Screw(s) and key are included with each tool holder.

Porte-outils spéciaux pour machines Tornos DECO 20 / 26

Sonderhalter für Tornos DECO 20 / 26 Maschinen

Special holders für Tornos DECO 20 / 26 machines

## DECO 20

Pour le tronçonnage de petites pièces  
Zum Abstechen von kleinen Werkstücken  
For small parts parting off

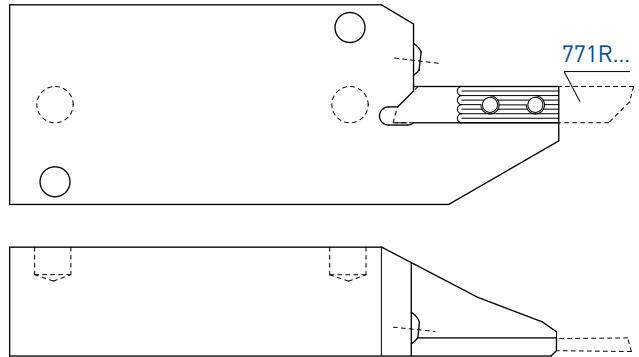

Art. N°	Plaquette type... WSP-Typ... Insert type...	Pages Seiten Pages
770R-DECO20	771R	1.134 - 1.137

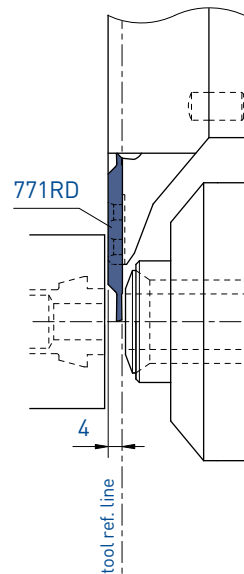
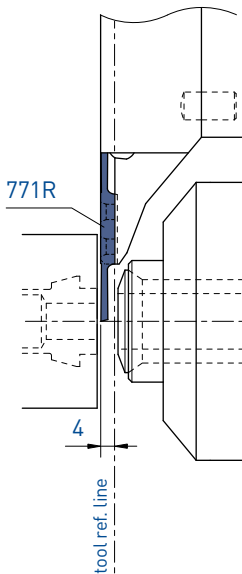

Chaque support est livré avec vis et clé.  
Jeder Halter wird mit Spannschraube(n) und Schlüssel geliefert.  
Screw(s) and key are included with each tool holder.

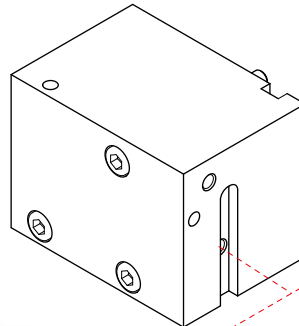
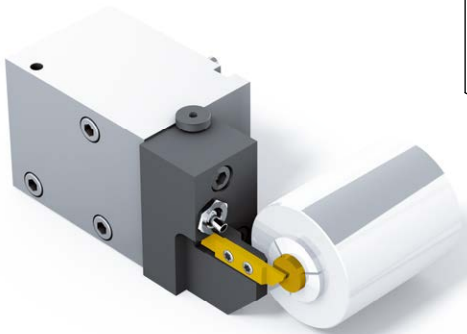
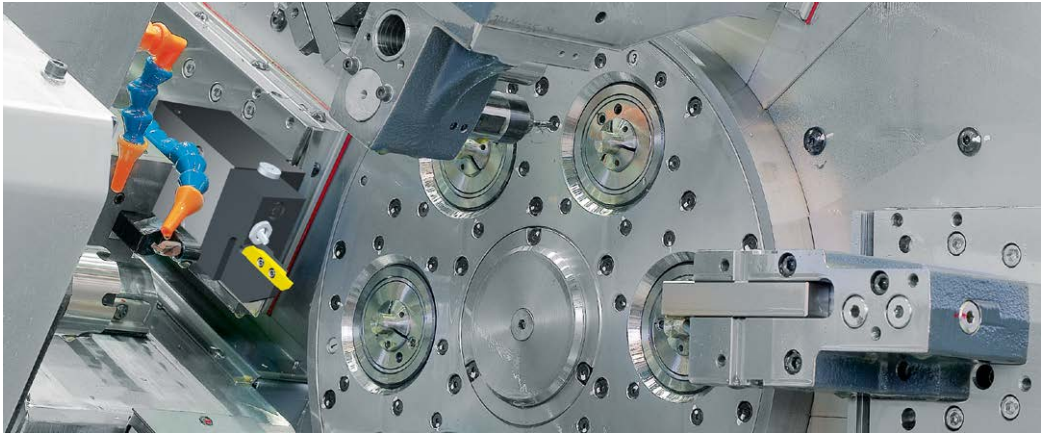

750R-MULTISWISS

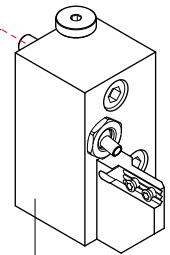
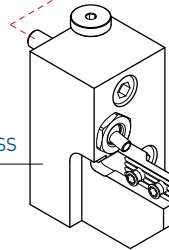

730R-MULTISWISS

**NEW**

Art. N°	Plaquettes type... WSP-Typ... Inserts type...	Pages Seiten Pages
<b>730R-MULTISWISS</b>	731R / 731N	1.47 - 1.53
<b>750R-MULTISWISS</b>	751R / 751N	1.93 - 1.103

Chaque support est livré avec vis et clé.  
Jeder Halter wird mit Spannschraube(n) und Schlüssel geliefert.  
Screw(s) and key are included with each tool holder.

Porte-outils

Halter

Holder

Tornos **AS 14**  
**SAS 16**

R

**750RAS**

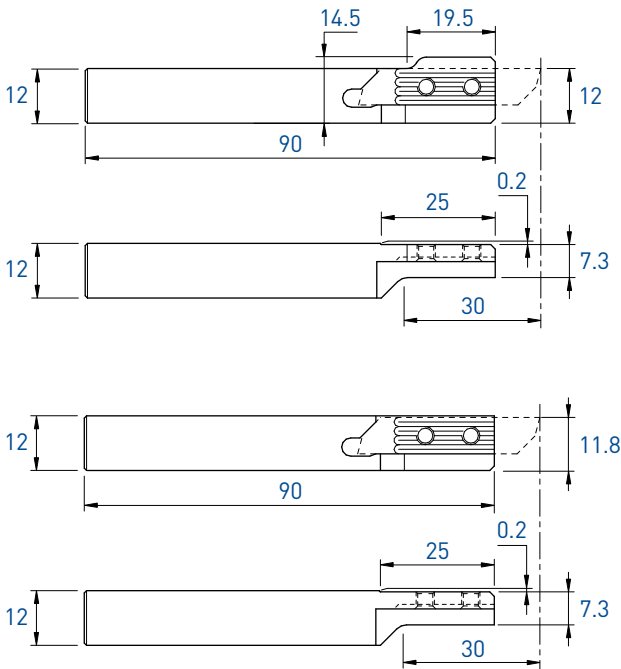

Art. N°	Plaquette type... WSP-Typ... Insert type...	Pages Seiten Pages
750RAS-12	751R	1.93 - 1.103

Art. N°	Plaquette type... WSP-Typ... Insert type...	Pages Seiten Pages
750RAS-12-H11.8	751R	1.93 - 1.103

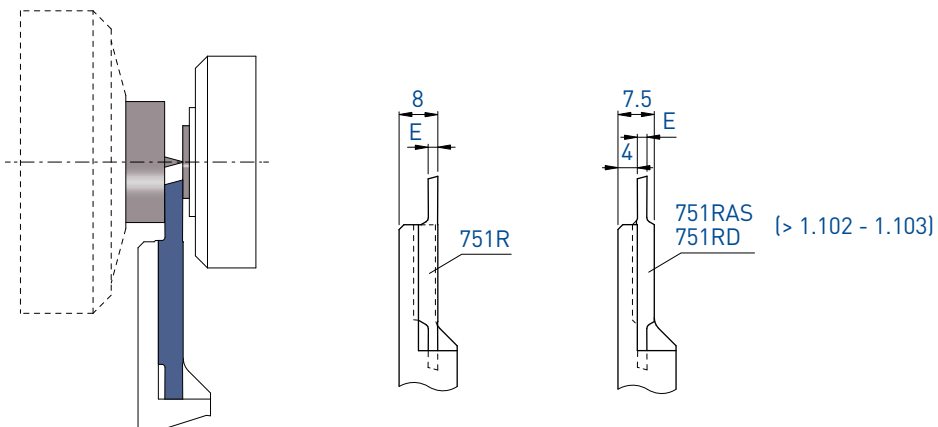

Chaque support est livré avec vis et clé.  
Jeder Halter wird mit Spannschraube(n) und Schlüssel geliefert.  
Screw(s) and key are included with each tool holder.

Nuances micro-grain à dureté élevée

Verschleissfeste Feinkornsorten

Wear resistant micro-grain grades

**NEW**

## HTC

μK10 + revêtement PDV  
μK10 + PVD Beschichtung  
μK10 + PVD coating

- nuance très résistante à l'usure, faible coefficient de frottement, recommandée pour des opérations d'ébauche et finition
- sehr verschleissfeste Sorte, geringer Reibwert, für Schruppen und Schlichtbearbeitung empfohlen
- very wear resistant grade, low friction ratio, recommended for roughing and finishing

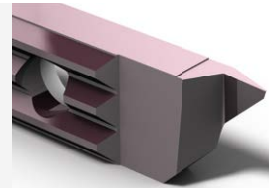

**NEW**

## HTC-RE

μK10 + revêtement PDV  
μK10 + PVD Beschichtung  
μK10 + PVD coating

- nuance très résistante à l'usure, faible coefficient de frottement, dépouille rectifiée après revêtement, recommandée pour les opérations de finition
- sehr verschleissfeste Sorte, nach Beschichtung geschliffener Freiwinkel, für Schlichtbearbeitung empfohlen
- very wear resistant grade, after coating grounded clearance, for finishing recommended

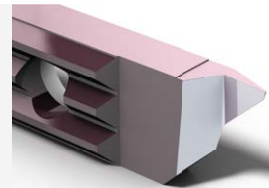

**NEW**

## HTAF

μK10 + revêtement PDV  
μK10 + PVD Beschichtung  
μK10 + PVD coating

- nuance très résistante à l'usure, recommandée pour les opérations d'ébauche, évite les arêtes rapportées
- sehr verschleissfeste Sorte, für Schruppen empfohlen, vermeidet Aufbauscheiden
- very wear resistant grade, recommended for roughing, avoids edge build up



## HTIN

μK10 + revêtement PDV  
μK10 + PVD Beschichtung  
μK10 + PVD coating

- nuance très résistante à l'usure, faible coefficient de frottement, recommandée pour les opérations d'ébauche et de finition
- sehr verschleissfeste Sorte, geringer Reibwert, für Schruppen und Schlichtbearbeitung empfohlen
- very wear resistant grade, low friction ratio, recommended for roughing and finishing



## HN (μK10)

non revêtu  
unbeschichtet  
uncoated

- nuance micro-grain très résistante à l'usure
- sehr verschleissfeste Feinkornsorte
- very wear resistant micro-grain grade



**NEW**

## XN (μK01)

non revêtu  
unbeschichtet  
uncoated

- nuance recommandée pour des matières non ferreuses
- für Nichteisenmaterial empfohlene Sorte
- grade recommended for non-ferrous material



**Outils de tournage spécifiques pour l'horlogerie**  
**Sonderdrehwerkzeuge für Uhrenindustrie**  
**Special turning tools for watch industry**



*pour machines à cames*  
*für kurvengesteuerte Maschinen*  
*for cam driven machines*

L

Porte-outils  
 Halter  
 Holders

**710 Series**> **1.162**

Plaquettes d'horlogerie pour machines à cames  
 Uhrenindustrie-WSP für kurvengesteuerte Maschinen  
 Watch industry inserts for cam driven machines

> **1.164**

Plaquette ébauche  
 WSP-Rohling  
 Blank insert

> **1.165**

*pour machines CNC*  
*für CNC-Maschinen*  
*for CNC driven machines*

R

Porte-outils  
 Halter  
 Holders

**740 Series**> **1.166**

Plaquettes d'horlogerie pour machines CNC  
 Uhrenindustrie-WSP für CNC-Maschinen  
 Watch industry inserts for CNC machines

> **1.168**

Plaquette ébauche  
 WSP-Rohling  
 Blank insert

> **1.169**

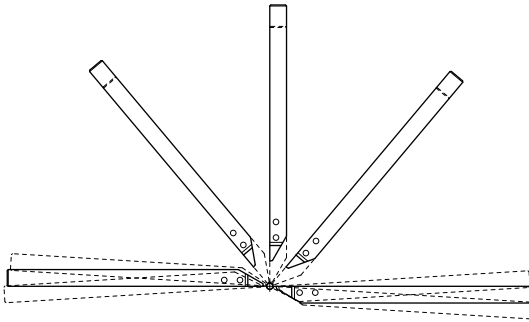

Porte-outils pour machines à cames à gauche  
 Halter für linksdrehende kurvengesteuerte Maschinen  
 Tool holders for left hand turning cam driven machines

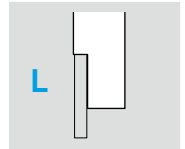
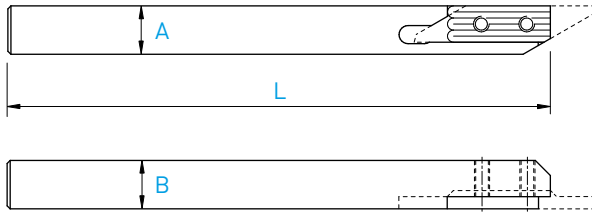

A x B	L	Serrage Spannsystem Clamping	Art. N°
6 x 6	115	A	<b>710-6</b>
7 x 7	115	A	<b>710-7</b>
8 x 8	115	A	<b>710-8</b>
8 x 8	140	A	<b>710-8-140</b>
10 x 10	115	A	<b>710-10</b>
12 x 12	130	A	<b>710-12</b>



Chaque support est livré avec vis et clé.  
 Jeder Halter wird mit Spanschraube(n) und Schlüssel geliefert.  
 Screw(s) and key are included with each tool holder.



Porte-outils

Halter

Holder

L

710-SF

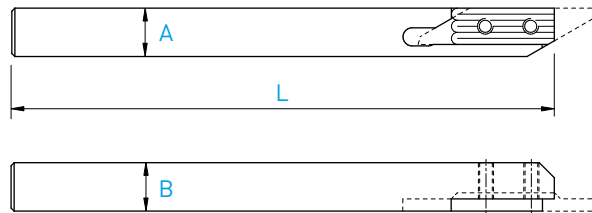

Super finition des 4 faces  
4 seitig feinstgeschliffen  
4 sides superfinish

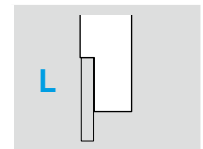

A x B	L	Serrage Spannsystem Clamping	Art. N°
7 x 7	140	A	<b>710-7-140-SF</b>
8 x 8	140	A	<b>710-8-140-SF</b>

Porte-outils en métal lourd anti-vibratoire

Schwingungdämpfender Schwermetallhalter

Low vibration heavy metal holders

710-NOVIBRA

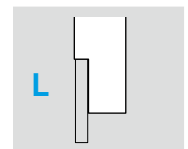
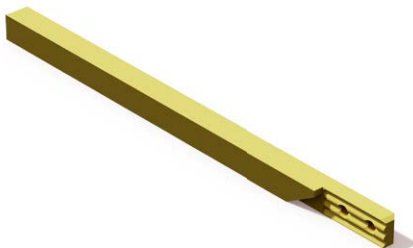

A x B	L	Serrage Spannsystem Clamping	Art. N°
6 x 6	115	A	<b>710-6-NOVIBRA</b>
7 x 7	115	A	<b>710-7-NOVIBRA</b>
8 x 8	115	A	<b>710-8-NOVIBRA</b>

Chaque support est livré avec vis et clé.  
Jeder Halter wird mit Spanschraube(n) und Schlüssel geliefert.  
Screw(s) and key are included with each tool holder.

Plaquettes d'horlogerie pour machines à cames

Uhrenindustrie-WSP für kurvengesteuerte Maschinen

Watch industry inserts for cam driven machines

L 711SF / 712SF

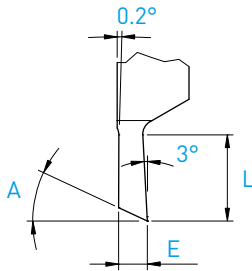
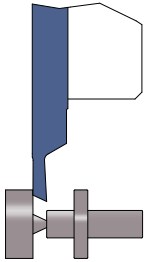

Tronçonnage  
Abstechen  
Parting off

E	L	A	Art. N°	HTC	HTC-RE	HTAF	HTIN	HN (µK10)
0.8	3.0	25°	711SF-0.8-25°	■	□	■	□	■
1.0	3.0	25°	711SF-1.0-25°	■	□	■	□	■

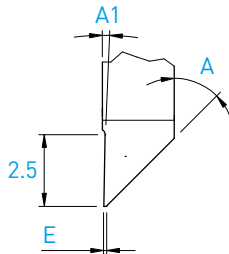
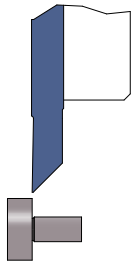

Tournage avant ébauche / finition  
Vorwärts drehen schruppen / schlichten  
Front turning for roughing / finishing

E	A	A1	Art. N°	HTC	HTC-RE	HTAF	HTIN	HN (µK10)
0.03	45°	3°	712SF-3/3-45°	■	□	■	□	■
0.08	45°	1°	712SF-8/8-45°	■	□	■	□	■

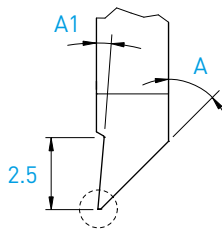
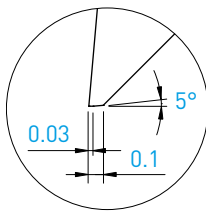
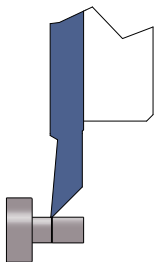

Tournage avant finition (pivotage)  
Vorwärts drehen schlichten  
Front turning for finishing

A	A1	Art. N°	HTC	HTC-RE	HTAF	HTIN	HN (µK10)
45°	3°	712SF-10/3	■	□	■	□	■

Plaquettes d'horlogerie pour machines à cames

Uhrenindustrie-WSP für kurvengesteuerte Maschinen

Watch industry inserts for cam driven machines

L

713SF

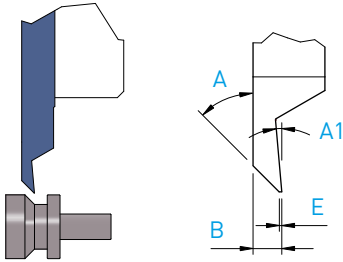

Tournage arrière ébauche / finition  
Rückwärts drehen schruppen / schlichten  
Back turning for roughing / finishing

E	B	A	A1	Art. N°	HTC	HTC-RE	HTAF	HTIN	HN (µK10)
0.03	1.0	45°	5°	713SF-3/3-45°-1.0	■	□	■	□	■
0.1	1.0	45°	5°	713SF-10/10-45°-1.0	■	□	■	□	■

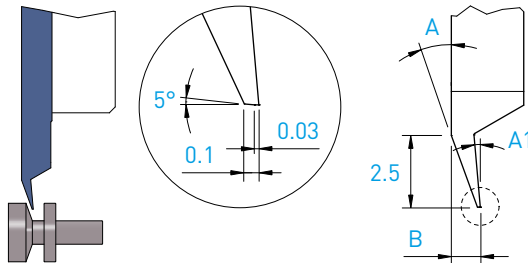

Tournage arrière finition  
Rückwärts drehen schlichten  
Back turning for finishing

B	A	A1	Art. N°	HTC	HTC-RE	HTAF	HTIN	HN (µK10)
1.0	20°	5°	713SF-10/3	■	□	■	□	■

Plaquette ébauche

WSP-Rohling

Blank insert

L

711-ESF

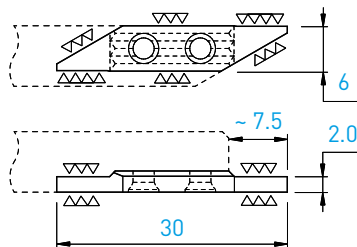

Art. N°	HTC	HTAF	HN (µK10)
711-ESF	■	■	■

Porte-outils

Halter

Holder

L / R

730 / 740

L

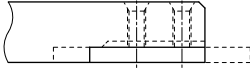
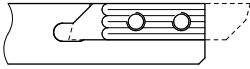

R

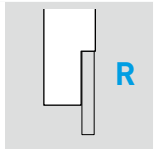
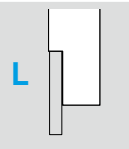
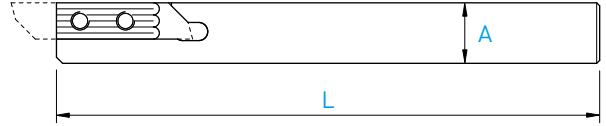

A x B	L	Serrage Spannsystem Clamping	Art. N°	Art. N°
7 x 7	115	A	<b>730-7</b>	<b>740-7</b>
8 x 8	115	A + B	<b>730-8</b>	<b>740-8</b>
8 x 8	140	A + B	<b>730-8-140</b>	-
10 x 10	115	A + B	<b>730-10</b>	<b>740-10</b>
12 x 12	130	A + B	<b>730-12</b>	<b>740-12</b>
12 x 12	90	A + B	<b>730-12-90</b>	<b>740-12-90</b>



Chaque support est livré avec vis et clé.  
Jeder Halter wird mit Spannschraube(n) und Schlüssel geliefert.  
Screw(s) and key are included with each tool holder.

Porte-outils

Halter

Holder

R

740-SF

L

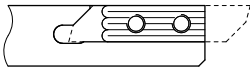

R

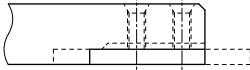
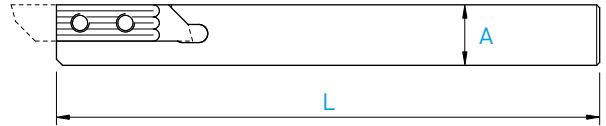

Super finition des 4 faces  
4 seitig feinstgeschliffen  
4 sides superfinish

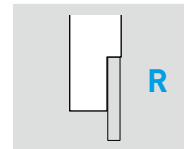
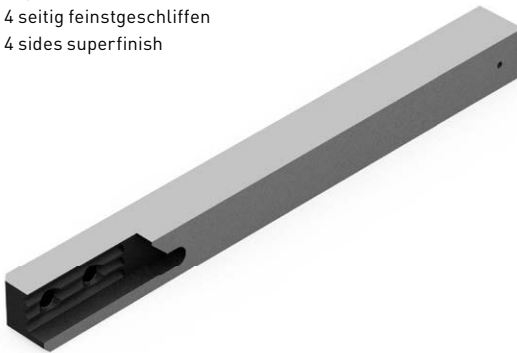

A x B	L	Serrage Spannsystem Clamping	Art. N°
7 x 7	90	A	740-7-90-SF
8 x 8	115	A + B	740-8-SF
8 x 8	90	A + B	740-8-90-SF
10 x 10	115	A + B	740-10-SF
10 x 10	90	A + B	740-10-90-SF
12 x 12	130	A + B	740-12-SF
12 x 12	90	A + B	740-12-90-SF

Porte-outils en métal lourd anti-vibratoire

Schwingungsdämpfender Schwermetallhalter

Low vibration heavy metal holders

L / R 730 / 740-NOVIBRA

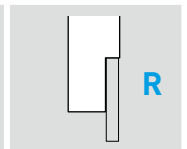
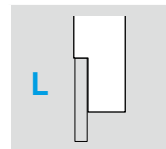

A x B	L	Serrage Spannsystem Clamping	Art. N°	Art. N°
7 x 7	115	A	730-7-NOVIBRA	740-7-NOVIBRA
8 x 8	115	A + B	730-8-NOVIBRA	740-8-NOVIBRA
10 x 10	115	A + B	-	740-10-NOVIBRA
12 x 12	130	A + B	-	740-12-NOVIBRA

Chaque support est livré avec vis et clé.  
Jeder Halter wird mit Spannschraube(n) und Schlüssel geliefert.  
Screw(s) and key are included with each tool holder.

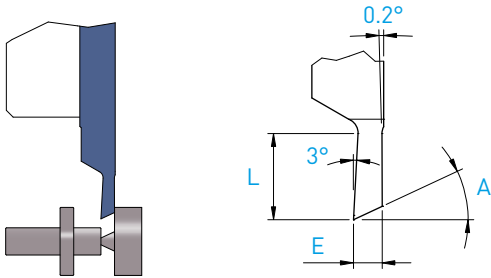

Tronçonnage  
Abstechen  
Parting off

E	L	A	Art. N°	HTC	HTC-RE	HTAF	HTIN	HN (µK10)	XN (µK01)
0.8	3.0	25°	741SF-0.8-25°	■	□	■	□	■	□
1.0	3.0	25°	741SF-1.0-25°	■	□	■	□	■	□
1.2	6.0	22°	741SF-1.2-22°	■	□	■	□	■	□

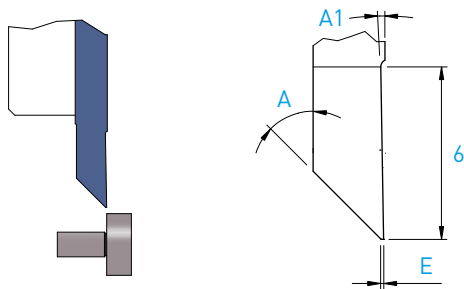

Tournage avant ébauche / finition  
Vorwärts drehen schruppen / schlichten  
Front turning for roughing / finishing

E	A	A1	Art. N°	HTC	HTC-RE	HTAF	HTIN	HN (µK10)	XN (µK01)
0.03	45°	3°	742SF-3/3-45°	■	■	■	□	■	□
0.08	45°	1°	742SF-8/8-45°	■	□	■	□	■	□

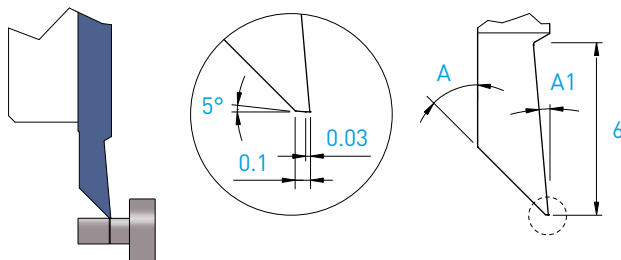

Tournage avant finition (pivotage)  
Vorwärts drehen schlichten  
Front turning for finishing

A	A1	Art. N°	HTC	HTC-RE	HTAF	HTIN	HN (µK10)	XN (µK01)
45°	5°	742SF-10/3	■	■	■	□	■	□

7XX-XX-B



Sur demande pour serrage type B, voir page 1.03  
Wahlweise für B-Spannsystem, siehe Seite 1.03  
On request for B clamping system, see page 1.03

Plaquettes d'horlogerie pour machines CNC

Uhrenindustrie-WSP für CNC-Maschinen

Watch industry inserts for CNC machines

R

743SF

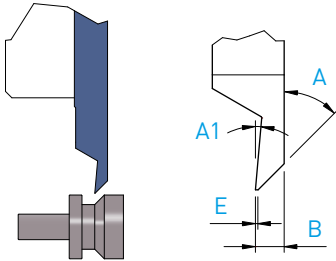

Tournage arrière ébauche/finition  
Rückwärts drehen schrappen/schlichten  
Back turning for roughing/finishing

E	B	A	A1	Art. N°	HTC	HTC-RE	HTAF	HTIN	HN (µK10)	XN (µK01)
0.03	1.0	45°	5°	743SF-3/3-45°-1.0	■	■	■	□	■	□
0.03	1.2	45°	5°	743SF-3/3-45°-1.2	■	■	■	□	■	□
0.1	1.0	45°	5°	743SF-10/10-45°-1.0	■	□	□	□	■	□

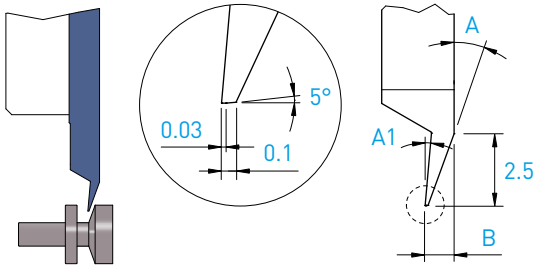

Tournage arrière finition  
Rückwärts drehen schlichten  
Back turning for finishing

B	A	A1	Art. N°	HTC	HTC-RE	HTAF	HTIN	HN (µK10)	XN (µK01)
1.0	20°	5°	743SF-10/3	■	■	■	□	■	□

Plaquette ébauche

WSP-Rohling

Blank insert

R

741-ESF

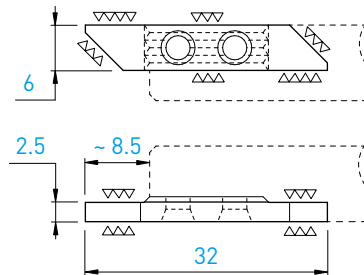
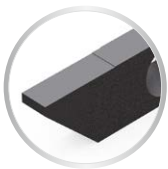

Art. N°	HTC	HTAF	HN (µK10)	XN (µK01)
741-ESF	■	■	■	□

7XX-XX-B



Sur demande pour serrage type B, voir page 1.03  
Wahlweise für B-Spannsystem, siehe Seite 1.03  
On request for B clamping system, see page 1.03

# TOP-Watch

Plaquettes piqûre avant

Frontestich WSP

Front grooving inserts

R

748SF

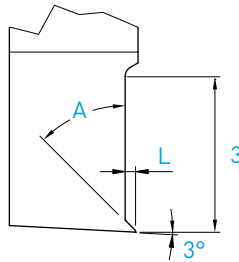
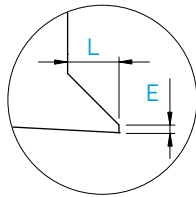
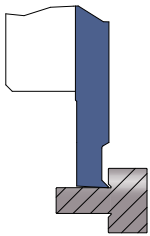

E 0/-0.01	A	L	Art. N°	HTC	HTC-RE	HTAF	HTIN	HN (µK10)
0.03	45°	0.2	748SF-E03-A45°-L20	■	□	■	□	■
0.05	45°	0.3	748SF-E05-A45°-L30	■	□	■	□	■
0.08	45°	0.5	748SF-E08-A45°-L50	■	□	■	□	■

Plaquettes piqûre arrière

Rückestich WSP

Back grooving inserts

R

749SF

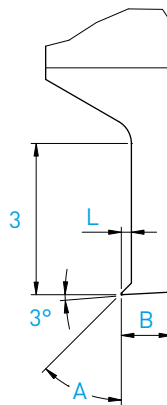
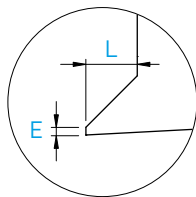
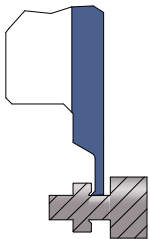

E 0/-0.01	A	L	B	Art. N°	HTC	HTC-RE	HTAF	HTIN	HN (µK10)
0.03	45°	0.2	1.0	749SF-E03-A45°-L20-B100	■	□	■	□	■
0.05	45°	0.3	1.0	749SF-E05-A45°-L30-B100	■	□	■	□	■
0.08	45°	0.5	1.2	749SF-E08-A45°-L50-B120	■	□	■	□	■

7XX-XX-B



Sur demande pour serrage type B, voir page 1.03  
Wahlweise für B-Spannsystem, siehe Seite 1.03  
On request for B clamping system, see page 1.03



Tronçonnage  
Abstechen  
Parting off

Coupe déportée  
Versetztes Schneiden  
Cut off line

## 731RSF

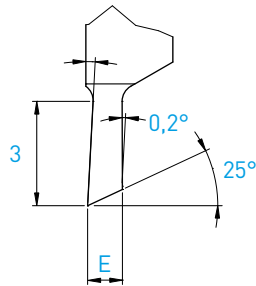
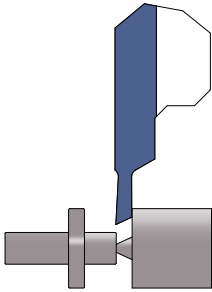

**L (R)**  
Coupe à droite déportée  
Versetztes Rechtsschneiden  
Right cut off line

E	Art. N°	HTC	HTC-RE	HTAF	HTIN	HN (µkt10)	XN (µkt10)
1.0	731RSF-1.0-25°			■	■	■	

Tronçonnage  
Abstechen  
Parting off

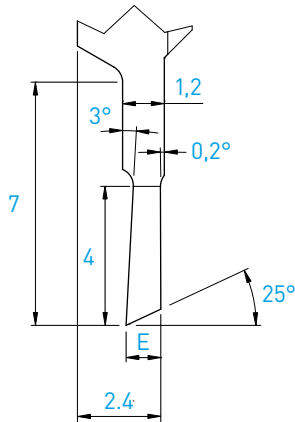
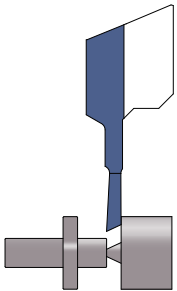

Coupe déportée  
Versetztes Schneiden  
Cut off line

## 731RDSF

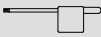

**L (R)**  
Coupe à droite déportée  
Versetztes Rechtsschneiden  
Right cut off line

E	Art. N°	HTC	HTC-RE	HTAF	HTIN	HN (µkt10)	XN (µkt10)
1.0	731RDSF-1.0-25°			■	□	■	



	Porte-outils Halter Holders	Serrage standard (A) Standard Spannsystem (A) Standard clamping system (A)		Serrage type B Spannsystem Typ B Clamping system type B	
					
<b>300</b>	311	V-M2.5X6.5-T8	C-T8	-	-
	312 - 316	V-M2.5X7.8-T8	C-T8	-	-
	322 - 326	V-M2.5X7.8-T8	C-T8	-	-
	332 - 336	V-M2.5X7.8-T8	C-T8	-	-
	342 - 346	V-M2.5X7.8-T8	C-T8	-	-
<b>710</b>	710-6	V-M2.5X5.8-T8	C-T8	-	-
	710-7	V-M2.5X6.5-T8	C-T8	-	-
	710-8 - 710-12	V-M2.5X7.8-T8	C-T8	-	-
<b>720</b>	720-7	V-M2.5X6.5-T8	C-T8	-	-
	720-8 - 720-12	V-M2.5X7.8-T8	C-T8	-	-
<b>730</b>	730-7	V-M3X7-T8	C-T8	-	-
	730-8 - 730-20	V-M3X7-T8	C-T8	V-M2.5X7.8-T8	C-T8
	730-DECO10	V-M3X7-T8	C-T8	-	-
	730R-DECO10	V-M3X7-T8	C-T8	-	-
	730RC	V-M3X5.5-T8	C-T8	-	-
<b>740</b>	740-7	V-M3X7-T8	C-T8	-	-
	740-8 - 740-20	V-M3X7-T8	C-T8	V-M2.5X7.8-T8	C-T8
	740/730-D	V-M3X7-T8	C-T8	-	-
	740-C	V-M3X5.5-T8	C-T8	-	-
	740-DECO10	V-M3X7-T8	C-T8	-	-
	740L-DECO10	V-M3X7-T8	C-T8	-	-
	740-Z	V-M3X9-T8	C-T8	-	-
<b>750</b>	750-10	V-M4X9-T15	C-T15	-	-
	750-10-AB	V-M4X9-T15	C-T15	V-M3X10-BN21	C-6P-2.0
	750-12	V-M4X9-T15	C-T15	-	-
	750-12-AB	V-M4X9-T15	C-T15	V-M3X8-BN11	C-6P-2.5
	750-12.7	V-M4X9-T15	C-T15	V-M3X10-BN11	C-6P-2.5
	750-14	V-M4X9-T15	C-T15	V-M3X10-BN11	C-6P-2.5
	750-16	V-M4X9-T15	C-T15	V-M3X12-BN11	C-6P-2.5
	750-20	V-M4X9-T15	C-T15	V-M3X16-BN11	C-6P-2.5
	750RAS	V-M4X7.3-T15	C-T15	-	-
	750RC	V-M4X7.3-T15	C-T15	-	-
	750R-DECO10	V-M4X5.6-T15	C-T15	-	-
<b>760</b>	760-10	V-M4X9-T15	C-T15	-	-
	760-10-AB	V-M4X9-T15	C-T15	V-M3X10-BN21	C-6P-2.0
	760-12	V-M4X9-T15	C-T15	-	-
	760-12-AB	V-M4X9-T15	C-T15	V-M3X8-BN11	C-6P-2.5
	760-12.7	V-M4X9-T15	C-T15	V-M3X10-BN11	C-6P-2.5
	760-14	V-M4X9-T15	C-T15	V-M3X10-BN11	C-6P-2.5
	760-16	V-M4X9-T15	C-T15	V-M3X12-BN11	C-6P-2.5
	760-20	V-M4X9-T15	C-T15	V-M3X16-BN11	C-6P-2.5
	760/750-25	V-M4X9-T15	C-T15	-	-
	760/750-D	V-M4X9-T15	C-T15	-	-
	760LC	V-M4X7.3-T15	C-T15	-	-
	760L-DECO10	V-M4X5.6-T15	C-T15	-	-
	760-Z	V-M4X12-T15	C-T15	-	-

## Vis et clés de rechange

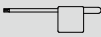

## Ersatzschrauben und Schlüssel

## Spare screws and keys

## TOP-Line

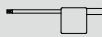
	Porte-outils Halter Holders	Serrage standard (A) Standard Spannsystem (A) Standard clamping system (A)		Serrage type B Spannsystem Typ B Clamping system type B	
					
<b>770</b>	770-12 - 770-25	<b>V-M4X9-T15</b>	<b>C-T15</b>	-	-
	770R-DECO13	<b>V-M4X7.3-T15</b>	<b>C-T15</b>	-	-
	770R-DECO20	<b>V-M4X7.3-T15</b>	<b>C-T15</b>	-	-
<b>780</b>	780-12 - 780-25	<b>V-M4X9-T15</b>	<b>C-T15</b>	-	-
<b>7050</b>	7050-16 - 7050-25	<b>V-M4X9-T15</b>	<b>C-T15</b>	-	-
<b>7060</b>	7060-16 - 7060-25	<b>V-M4X9-T15</b>	<b>C-T15</b>	-	-
<b>W</b>	W750	<b>V-M4X11.5-T15</b>	<b>C-T15</b>	-	-
	W760	<b>V-M4X11.5-T15</b>	<b>C-T15</b>	-	-

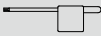
	Porte-outils Halter Holders	Raccord Kühlmittel- anschluss Connector	Bouchon Stopsel Plug	Serrage standard (A) Standard Spannsystem (A) Standard clamping system (A)		Buse Düse Nozzle
						
<b>JET</b>	340-JET	<b>J-M8X1-D6</b>	<b>JB-M8X1</b>	<b>V-M2.5X7.8-T8</b>	<b>C-T8</b>	-
	730-JET	<b>J-M8X1-D6</b>	<b>JB-M8X1</b>	<b>V-M3X7-T8</b>	<b>C-T8</b>	<b>JJ-M3X6-D1.5</b>
	740-JET	<b>J-M8X1-D6</b>	<b>JB-M8X1</b>	<b>V-M3X7-T8</b>	<b>C-T8</b>	<b>JJ-M3X6-D1.5</b>
	750-JET	<b>J-M8X1-D6</b>	<b>JB-M8X1</b>	<b>V-M4X9-T15</b>	<b>C-T15</b>	<b>JJ-M3X6-D1.5</b>
	760-JET	<b>J-M8X1-D6</b>	<b>JB-M8X1</b>	<b>V-M4X9-T15</b>	<b>C-T15</b>	<b>JJ-M3X6-D1.5</b>
	W750-JET	<b>J-M8X1-D6</b>	<b>JB-M8X1</b>	<b>V-M4X11.5-T15</b>	<b>C-T15</b>	<b>JJ-M3X6-D1.5</b>
	W760-JET	<b>J-M8X1-D6</b>	<b>JB-M8X1</b>	<b>V-M4X11.5-T15</b>	<b>C-T15</b>	<b>JJ-M3X6-D1.5</b>

	Porte-outils Halter Holders	Serrage standard (A) Standard Spannsystem (A) Standard clamping system (A)		Serrage type B Spannsystem Typ B Clamping system type B	
					
<b>NOVIBRA</b>	710-6-NOVIBRA	<b>V-M2.5X5.8-T8</b>	<b>C-T8</b>	-	-
	710-7-NOVIBRA	<b>V-M2.5X6.5-T8</b>	<b>C-T8</b>	-	-
	710-8-NOVIBRA	<b>V-M2.5X7.8-T8</b>	<b>C-T8</b>	-	-
	730-7-NOVIBRA	<b>V-M3X7-T8</b>	<b>C-T8</b>	-	-
	730-8-NOVIBRA	<b>V-M3X7-T8</b>	<b>C-T8</b>	<b>V-M2.5X7.8-T8</b>	<b>C-T8</b>
	740-7-NOVIBRA	<b>V-M3X7-T8</b>	<b>C-T8</b>	-	-
	740-8-NOVIBRA - 740-12-NOVIBRA	<b>V-M3X7-T8</b>	<b>C-T8</b>	<b>V-M2.5X7.8-T8</b>	<b>C-T8</b>
	760-NOVIBRA	<b>V-M4X9-T15</b>	<b>C-T15</b>	-	-
<b>SF</b>	710-7-140-SF	<b>V-M2.5X6.5-T8</b>	<b>C-T8</b>	-	-
	710-8-140-SF	<b>V-M2.5X7.8-T8</b>	<b>C-T8</b>	-	-
	740-7-SF	<b>V-M3X7-T8</b>	<b>C-T8</b>	-	-
	740-8-SF - 740-12-SF	<b>V-M3X7-T8</b>	<b>C-T8</b>	<b>V-M2.5X7.8-T8</b>	<b>C-T8</b>

TRIO-Line

APPLITEC

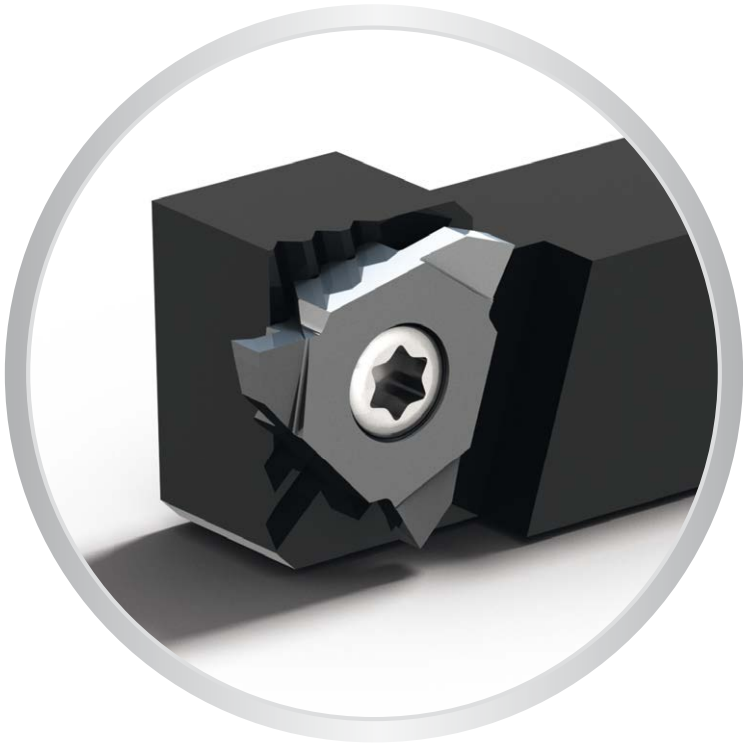

PERFORMANCE | PRECISION | RIGIDITY

Conseils d'utilisation - Accessoires  
 Anwendungsempfehlungen - Zubehör  
 Application recommendations - Accessories



> **2.03**

Porte-outils  
 Halter  
 Holders

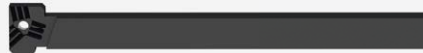

> **2.04**

**GX**

Gorge de précision  
 Präzisionseinstechen  
 High precision grooving

DIN6799  
 & DIN471



> **2.05**

**FT**

Tournage finition  
 Schlicht drehen  
 Fine turning



> **2.06**

**GT**

Foncer tourner  
 Einstechen und drehen  
 Grooving and turning



> **2.07**

**GTX**

Foncer tourner avec coupe positive  
 Einstechen und drehen mit positivem Spanwinkel  
 Grooving and turning with positive cut

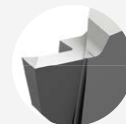

> **2.08**

**EP**

Plaquette ébauche  
 WSP-Rohling  
 Blank insert



> **2.09**

*Rigid clamping system with the famous  
Applitec teeth clamping*

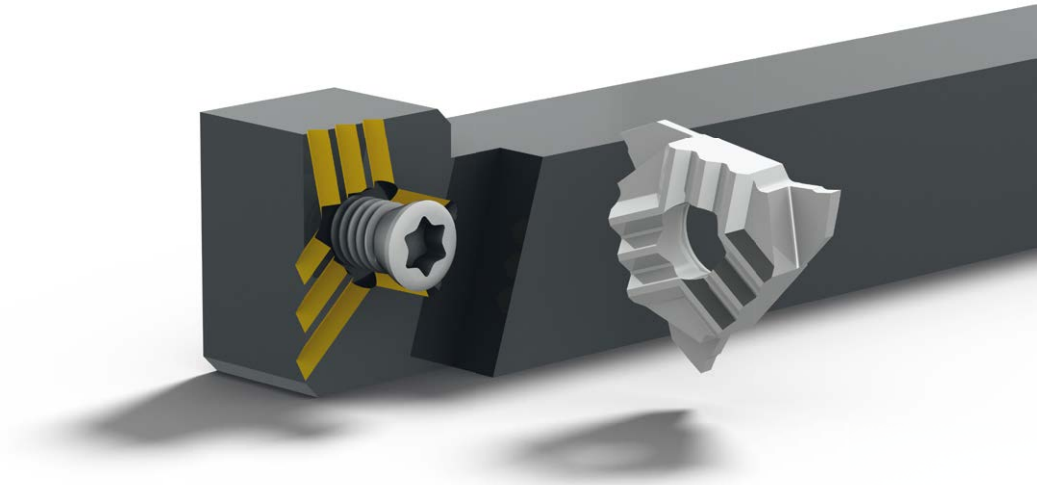

**Nuance micro-grain à dureté élevée**

**Verschleissfeste Feinkornsorten**

**Wear resistant micro-grain grades**

## HTA

$\mu$ K10 + revêtement PVD  
 $\mu$ K10 + PVD Beschichtung  
 $\mu$ K10 + PVD coating

- nuance très résistante à l'usure
- pour l'usinage en finition dans des conditions favorables des aciers, aciers inoxydables et alliages de titane

- sehr verschleissfeste Sorte
- für die Feinbearbeitung von Stahl, rostfreiem Stahl und Titanlegierungen bei guten Bearbeitungsbedingungen

- very wear resistant grade
- for light machining of steel, stainless steel and titanium alloys under favourable machining conditions

## HN ( $\mu$ K10)

non revêtu  
unbeschichtet  
uncoated

- nuance micro-grain très résistante à l'usure
- recommandé pour l'usinage du laiton, de l'aluminium et du titane faiblement allié

- sehr verschleissfeste Feinkornsorte
- empfehlenswert für die Bearbeitung von Messing und niedrig legiertem Aluminium und Titan

- very wear resistant micro-grain grade
- suitable for the machining of brass and low alloyed aluminium and titanium

## Paramètres de coupe indicatifs

## Empfohlene Schnittwerte

## Standard machining data

Matière Werkstoff Material	Tournage Drehen Turning		Foncer Einstechen Grooving	
	VC (m/min)	F (mm/U)	VC (m/min)	F (mm/U)
Acier de décolletage Automatenstahl Free-cutting steel	120 - 200	0.01 - 0.20	80 - 150	0.01 - 0.15
Acier Stahl Steel < 600 N/mm <sup>2</sup>	80 - 160	0.01 - 0.18	70 - 120	0.01 - 0.12
Acier Stahl Steel < 800 N/mm <sup>2</sup>	60 - 120	0.01 - 0.15	60 - 100	0.01 - 0.10
Acier Stahl Steel > 800 N/mm <sup>2</sup>	50 - 100	0.01 - 0.12	40 - 80	0.01 - 0.08
Acier inoxydable Rostfreistahl Stainless steel	60 - 120	0.01 - 0.15	60 - 100	0.01 - 0.08
Aluminium	180 - 800	0.01 - 0.30	150 - 300	0.01 - 0.20
Titane Titan Titanium	30 - 70	0.01 - 0.12	30 - 50	0.01 - 0.06
Cuivre, laiton, bronze Kupfer, Messing, Bronze Copper, brass, bronze	100 - 500	0.01 - 0.30	100 - 300	0.01 - 0.20

## Accessoires

## Zubehöre

## Accessories

Porte-outils Halter Holders			Option Art. N°
T216-H...	V-M4X9-T15	T15	SET-NM-TX15

Recommandation de serrage  
Drehmoment Empfehlung  
Clamping recommendation

3.0 Nm



SET-NM-TX15

# TRIO-Line

Porte-outils

Halter

Holder

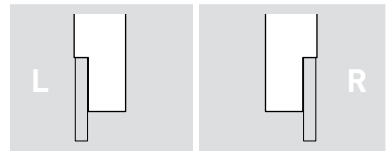
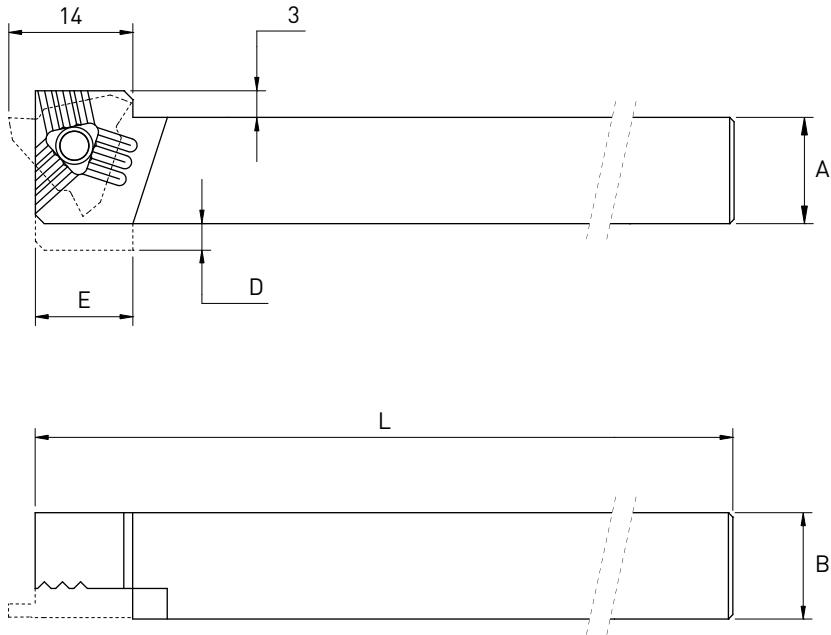

Chaque support est livré avec vis et clé.  
 Jeder Halter wird mit Spannschraube(n)  
 und Schlüssel geliefert.  
 Screw(s) and key are included with each  
 tool holder.

A	B	D	E	L	Art. N°	Art. N°
8	10	4	11	115	T216-H0810L	T216-H0810R
10	10	2	8	130	T216-H1010L	T216-H1010R
12	12	-	-	130	T216-H1212L	T216-H1212R
12	12	-	-	90	T216-H1212L-90	T216-H1212R-90
16	16	-	-	120	T216-H1616L	T216-H1616R
20	20	-	-	130	T216-H2020L	T216-H2020R



Plaquettes de gorge pour circlips

Einstechwendeplatte für Seegerring

Grooving inserts for retaining ring

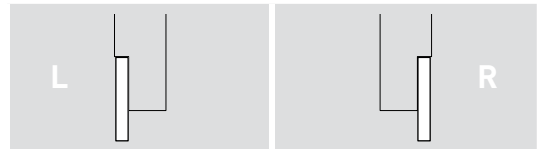
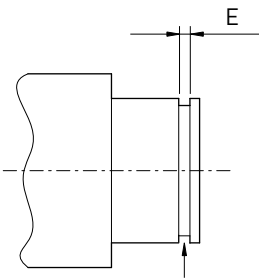
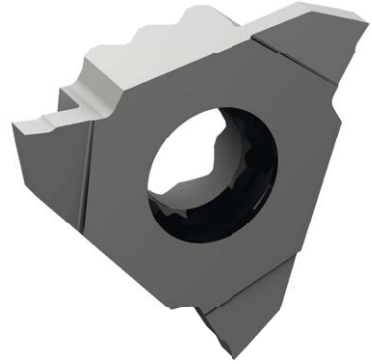
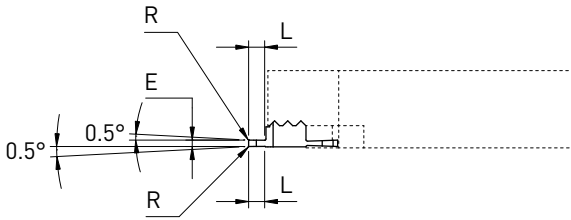
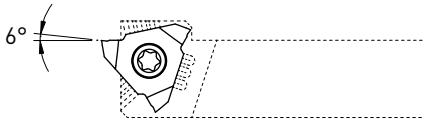

Selon DIN6799 et DIN471  
Gemäss DIN6799 und DIN471  
According to DIN6799 and DIN471



E ±0,01	L	R	L		R	
			Art. N°	HTA HN	Art. N°	HTA HN
0.26	0.8	0.03	T216L-GX026	■ ■	T216R-GX026	■ ■
0.36	0.8	0.03	T216L-GX036	■ ■	T216R-GX036	■ ■
0.46	0.8	0.03	T216L-GX046	■ ■	T216R-GX046	■ ■
0.50	1.5	0.03	T216L-GX050	■ ■	T216R-GX050	■ ■
0.57	1.5	0.03	T216L-GX057	■ ■	T216R-GX057	■ ■
0.67	1.5	0.03	T216L-GX067	■ ■	T216R-GX067	■ ■
0.77	2.0	0.03	T216L-GX077	■ ■	T216R-GX077	■ ■
0.87	2.0	0.03	T216L-GX087	■ ■	T216R-GX087	■ ■
0.97	2.5	0.03	T216L-GX097	■ ■	T216R-GX097	■ ■
1.00	2.5	0.03	T216L-GX100	■ ■	T216R-GX100	■ ■
1.10	2.5	0.03	T216L-GX110	■ ■	T216R-GX110	■ ■
1.20	2.5	0.03	T216L-GX120	■ ■	T216R-GX120	■ ■
1.30	2.5	0.03	T216L-GX130	■ ■	T216R-GX130	■ ■
1.50	2.5	0.03	T216L-GX150	■ ■	T216R-GX150	■ ■
1.60	2.5	0.03	T216L-GX160	■ ■	T216R-GX160	■ ■
1.85	2.5	0.03	T216L-GX185	■ ■	T216R-GX185	■ ■
2.00	2.5	0.03	T216L-GX200	■ ■	T216R-GX200	■ ■
2.50	2.5	0.03	T216L-GX250	■ ■	T216R-GX250	■ ■

# TRIO-Line

Tournage avant  
Vorwärts drehen  
Front turning

FT

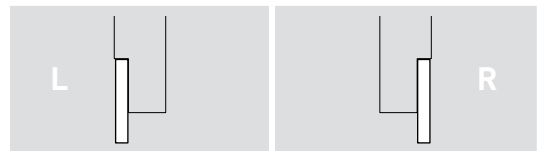
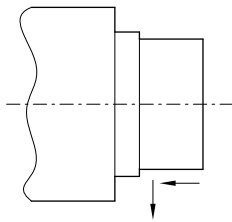
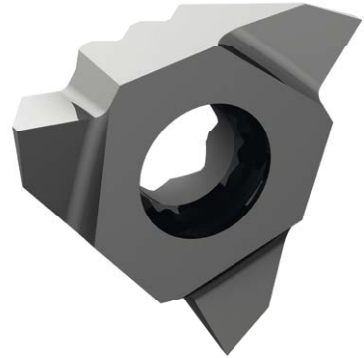
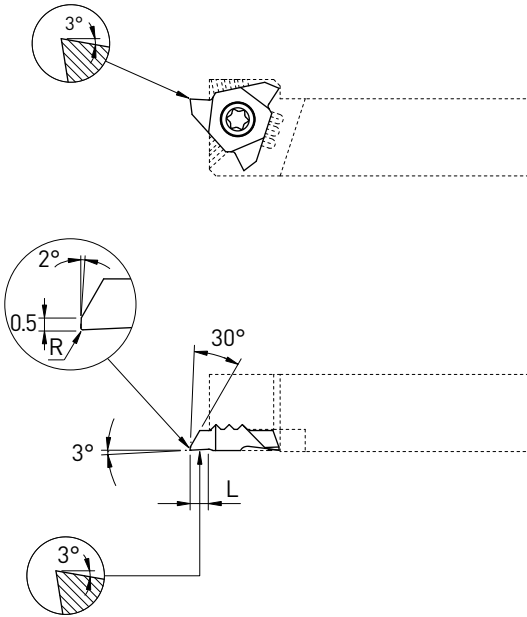

L	R	Art. N°	L		R		
			HTA	HN	HTA	HN	
3.0	0.03	T216L-FT	■	■	T216R-FT	■	■
3.0	0.08	T216L-FT-R08	■	■	T216R-FT-R08	■	■

Foncer-tourner

Einstecken und drehen

Grooving and turning

GT

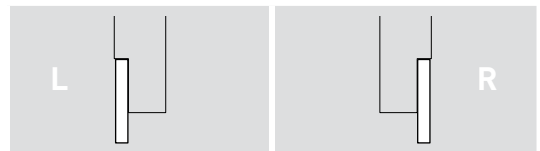
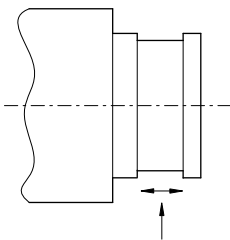
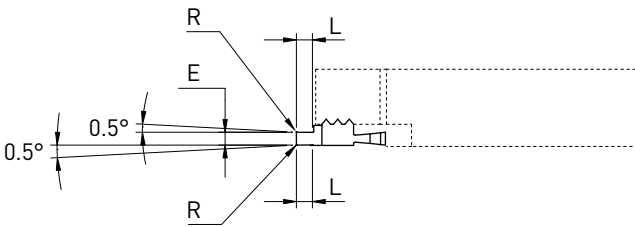
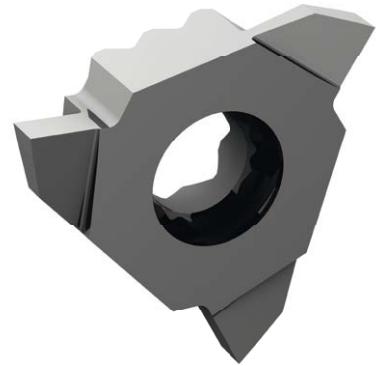
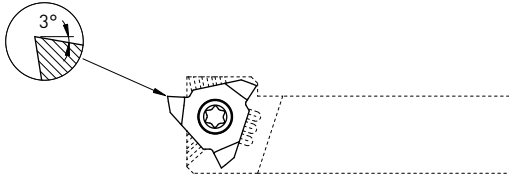

E	L	R	Art. N°	HTA		Art. N°	HTA	
				HN	HN		HN	HN
0.5	1.5	0.03	T216L-GT050	■	■	T216R-GT050	■	■
1.0	2.5	0.03	T216L-GT100	■	■	T216R-GT100	■	■
1.0	2.5	0.08	T216L-GT100-R08	■	■	T216R-GT100-R08	■	■
1.5	2.5	0.03	T216L-GT150	■	■	T216R-GT150	■	■
1.5	2.5	0.08	T216L-GT150-R08	■	■	T216R-GT150-R08	■	■
1.5	2.5	0.15	T216L-GT150-R15	■	■	T216R-GT150-R15	■	■
2.0	2.5	0.03	T216L-GT200	■	■	T216R-GT200	■	■
2.0	2.5	0.08	T216L-GT200-R08	■	■	T216R-GT200-R08	■	■
2.0	2.5	0.15	T216L-GT200-R15	■	■	T216R-GT200-R15	■	■
2.5	2.5	0.15	T216L-GT250-R15	■	■	T216R-GT250-R15	■	■

# TRIO-Line

Foncer-tourner

Einstecken und drehen

Grooving and turning

GTX

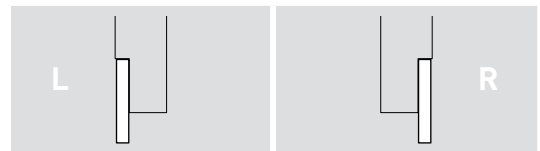
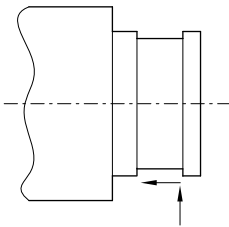
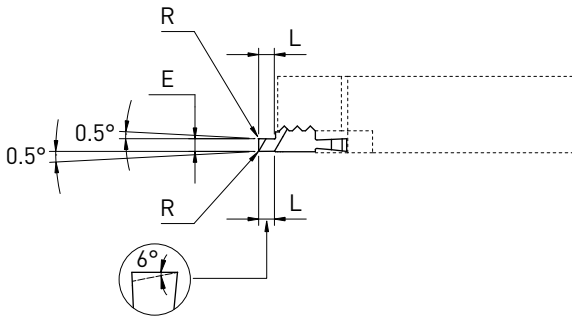
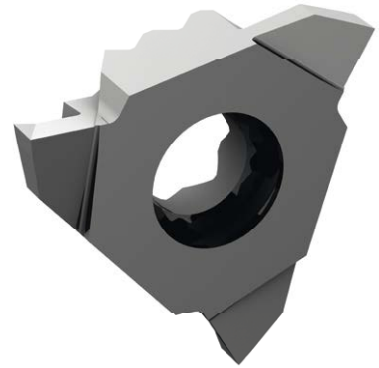
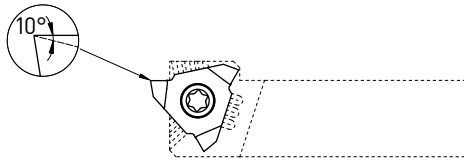

E	L	R	Art. N°	HTA		Art. N°	HN	
				HTA	HN		HTA	HN
1.0	2.5	0.03	T216L-GTX100	■	■	T216R-GTX100	■	■
1.0	2.5	0.08	T216L-GTX100-R08	■	■	T216R-GTX100-R08	■	■
1.5	2.5	0.03	T216L-GTX150	■	■	T216R-GTX150	■	■
1.5	2.5	0.08	T216L-GTX150-R08	■	■	T216R-GTX150-R08	■	■
1.5	2.5	0.15	T216L-GTX150-R15	■	■	T216R-GTX150-R15	■	■
2.0	2.5	0.03	T216L-GTX200	■	■	T216R-GTX200	■	■
2.0	2.5	0.08	T216L-GTX200-R08	■	■	T216R-GTX200-R08	■	■
2.0	2.5	0.15	T216L-GTX200-R15	■	■	T216R-GTX200-R15	■	■
2.5	2.5	0.15	T216L-GTX250-R15	■	■	T216R-GTX250-R15	■	■

Plaquette ébauche

WSP-Rohling

Blank insert

EP

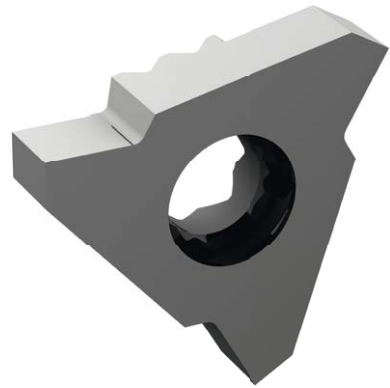
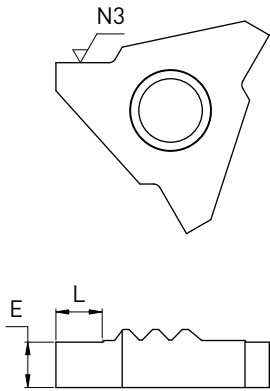

		L		R	
E	L	Art. N°	HTA HN	Art. N°	HTA HN
-3	3	T216L-EP	■	T216R-EP	■



261

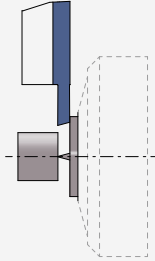

251R

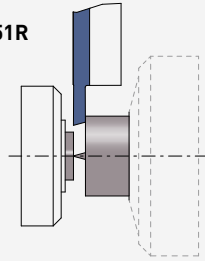

262

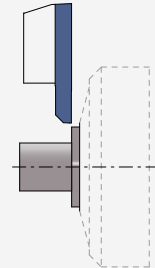

263

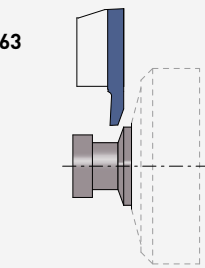

264

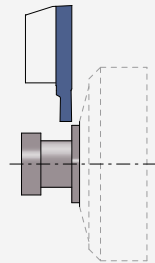

266

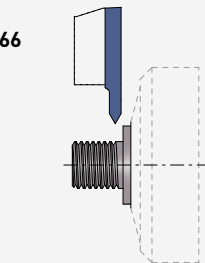

Nuances  
Sorten  
Grades > **3.02**

Paramètres de coupe indicatifs      Accessoires  
Empfohlene Schnittwerte              Zubehör  
Standard machining data              Accessories > **3.03**

Porte-outils  
Halter  
Holders > **3.04**



Tronçonnage  
Abstechen  
Parting off **Type 251 / 261**  > **3.08**

Tourneur avant  
Vorwärts drehen  
Front turning **Type 252 / 262**  > **3.10**

Tourneur arrière  
Rückwärts drehen  
Back turning **Type 253 / 263**  > **3.11**

Foncer-tourner  
Einstechen und drehen  
Grooving and turning **Type 254 / 264**  > **3.14**

Fileter  
Gewinde drehen  
Threading **Type 256 / 266**  > **3.16**

Plaquette ébauche  
WSP-Rohling  
Blank insert **Type 251E / 261E**  > **3.17**

# ECO-Line

Nuances

Sorten

Grades

**NEW**

## AP302

μK20 + revêtement PVD  
μK20 + PVD Beschichtung  
μK20 + PVD coating

- excellente nuance universelle
- 1<sup>er</sup> choix pour l'usinage des aciers, aciers inoxydables et alliages de titane
- très bonne résistance à la température

- beste Universalsorte
- für die Bearbeitung von Stahl, rostfreiem Stahl und Titanlegierungen bestens geeignet
- sehr gute Warmfestigkeit

- best universal grade
- first choice for steel, stainless steel and titanium alloys machining
- very good heat resistance

## AP202

μK20 + revêtement PVD  
μK20 + PVD Beschichtung  
μK20 + PVD coating

- nuance particulièrement adaptée aux faibles vitesses de coupe

- besonders geeignete Sorte für niedrige Schnittgeschwindigkeiten

- grade particularly suitable for low cutting speeds

## N (μK20)

non revêtu  
unbeschichtet  
uncoated

- nuance micro-grain tenace
- supporte les coupes interrompues et autres conditions d'usinage défavorables

- zähe Feinkornsorte
- für unterbrochene Schnitte und andere ungünstige Bearbeitungsbedingungen geeignet

- tough micro-grain grade
- suitable for interrupted cut and other unfavourable machining conditions

**NEW**

## AH302

μK10 + revêtement PVD  
μK10 + PVD Beschichtung  
μK10 + PVD coating

- nuance très résistante à l'usure
- pour l'usinage en finition dans des conditions favorables des aciers, aciers inoxydables et alliages de titane

- sehr verschleißfeste Sorte
- für die Feinbearbeitung von Stahl, rostfreiem Stahl und Titanlegierungen bei guten Bearbeitungsbedingungen

- very wear resistant grade
- for light machining of steel, stainless steel and titanium alloys under favourable machining conditions

**NEW**

## HN (μK10)

non revêtu  
unbeschichtet  
uncoated

- nuance micro-grain très résistante à l'usure
- recommandé pour l'usinage du titane faiblement allié
- déconseillé en cas de coupe interrompue et autres conditions d'usinage défavorables

- verschleißfeste Feinkornsorte
- empfehlenswert für die Bearbeitung von niedrig legiertem Titan
- für unterbrochene Schnitte und andere ungünstige Bearbeitungsbedingungen nicht geeignet

- wear resistant micro-grain grade
- suitable for the machining of low alloyed titanium
- not suitable for interrupted cut and other unfavourable machining conditions

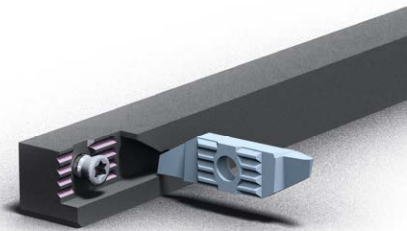

*Patented rigid  
clamping system*



## Paramètres de coupe indicatifs

## Empfohlene Schnittwerte



## Standard machining data

Matière Werkstoff Material	Tournage Drehen Turning		Tronçonnage Abstechen Parting off	
	VC (m/min)	F (mm/U)	VC (m/min)	F (mm/U)
Acier de décolletage Automatenstahl Free-cutting steel	120 - 200	0.01 - 0.20	80 - 150	0.01 - 0.15
Acier Stahl Steel < 600 N/mm <sup>2</sup>	80 - 160	0.01 - 0.18	70 - 120	0.01 - 0.12
Acier Stahl Steel < 800 N/mm <sup>2</sup>	60 - 120	0.01 - 0.15	60 - 100	0.01 - 0.10
Acier Stahl Steel > 800 N/mm <sup>2</sup>	50 - 100	0.01 - 0.12	40 - 80	0.01 - 0.08
Acier inoxydable Rostfreistahl Stainless steel	60 - 120	0.01 - 0.15	60 - 100	0.01 - 0.08
Aluminium	180 - 800	0.01 - 0.30	150 - 300	0.01 - 0.20
Titane Titan Titanium	30 - 70	0.01 - 0.12	30 - 50	0.01 - 0.06
Cuivre, laiton, bronze Kupfer, Messing, Bronze Copper, brass, bronze	100 - 500	0.01 - 0.30	100 - 300	0.01 - 0.20

## Accessoires

## Zubehöre

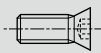
## Accessories

Porte-outils Halter Holder			Option Art. N°
250-... / 260-...	<b>V-M4X9-T15</b>	<b>C-T15</b>	<b>SET-NM-TX15</b>
250-8 / 260-8	<b>V-M3.5X7-T15</b>		
250RC / 260-C	<b>V-M4X7.3-T15</b>		

Recommandation de serrage  
Drehmoment Empfehlung  
Clamping recommendation

3.0 Nm



SET-NM-TX15

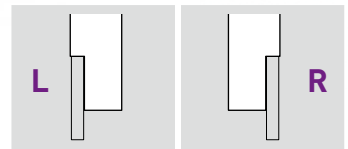
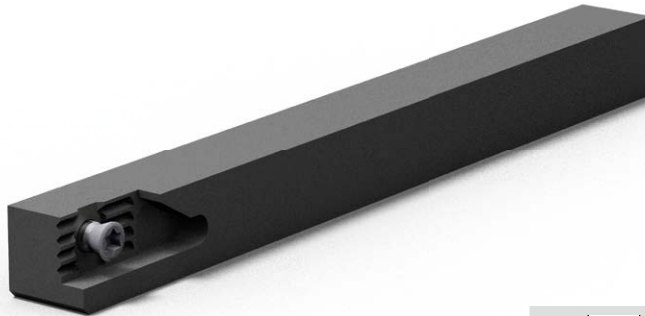
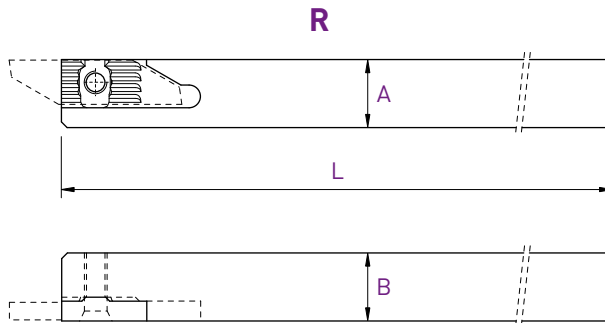

A x B	L	Art. N°	Art. N°
8 x 8	115	<b>250-8</b>	<b>260-8</b>
10 x 10	115	<b>250-10</b>	<b>260-10</b>
12 x 12	130	<b>250-12</b>	<b>260-12</b>
12 x 12	90	<b>250-12-90</b>	<b>260-12-90</b>
12.7 x 12.7	130	<b>250-12.7</b>	<b>260-12.7</b>
16 x 16	130	<b>250-16</b>	<b>260-16</b>
16 x 16	75	<b>250-16-75</b>	<b>260-16-75</b>
20 x 20	120	<b>250-20</b>	<b>260-20</b>

Chaque support est livré avec vis et clé.

Jeder Halter wird mit Spannschraube(n) und Schlüssel geliefert.

Screw(s) and key are included with each tool holder.

Porte-outils

Halter

Holder

260-C

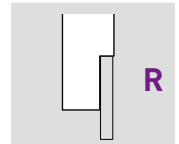
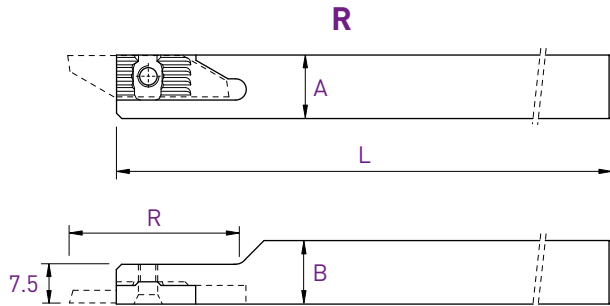
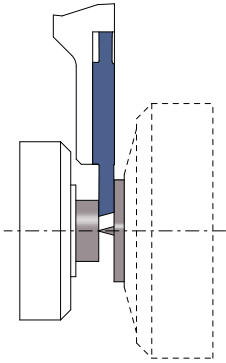

A x B	L	R	Art. N°
12 x 12	130	30	260-C-12

Porte-outils

Halter

Holder

Coupe à droite déportée

Versetztes Rechtsschneiden

Right cut off line

250RC

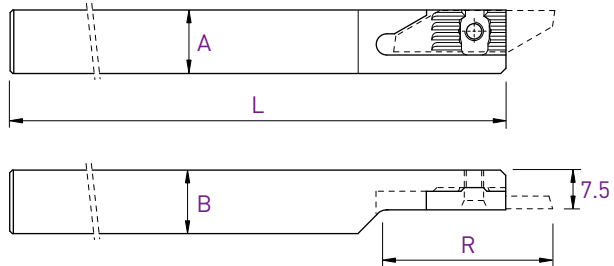
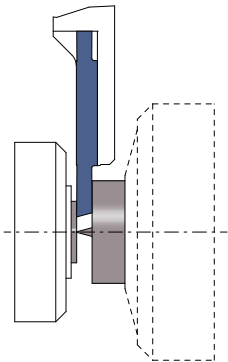

Utiliser des plaquettes type 251R  
WSP Typ 251R verwenden  
Use inserts type 251R

L (R)			Art. N°
A x B	L	R	
12 x 12	130	30	250RC-12
16 x 16	130	40	250RC-16

Chaque support est livré avec vis et clé.  
Jeder Halter wird mit Spannschraube(n) und Schlüssel geliefert.  
Screw(s) and key are included with each tool holder.

# ECO-Line

Porte-outils avec arrosage intégré



Halter mit integriertem Kühlmittelzufuhr

Holder with integrated coolant supply

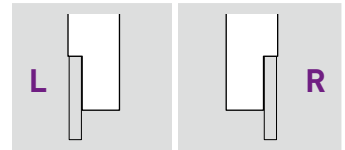
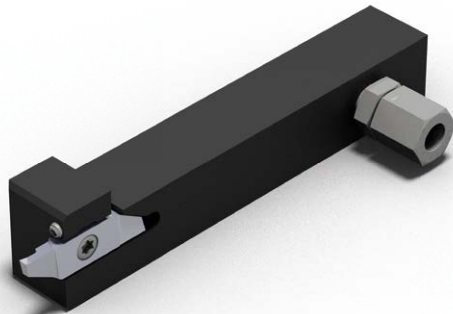
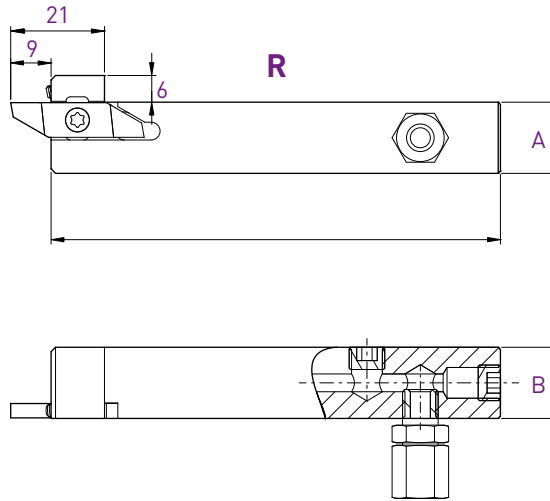
250JET / 260JET



A x B	L	Art. N°	Art. N°
10 x 12	100	250-1012-JET	260-1012-JET
12 x 12	100	250-12-JET	260-12-JET
16 x 16	100	250-16-JET	260-16-JET
20 x 20	100	250-20-JET	260-20-JET

Pièces de rechange Ersatzteile Spare parts			Buse Düse Nozzle 
	Art. N°	Art. N°	Art. N°
250-JET / 260-JET	J-M8X1-D6	JB-M8X1	JJ-M3X6-D1.5

Chaque support est livré avec vis et clé.

Jeder Halter wird mit Spannschraube(n) und Schlüssel geliefert.

Screw(s) and key are included with each tool holder.

Porte-outils

Halter

Holder

## 260/250F

L/R

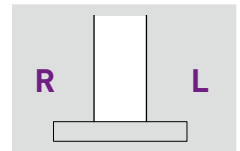
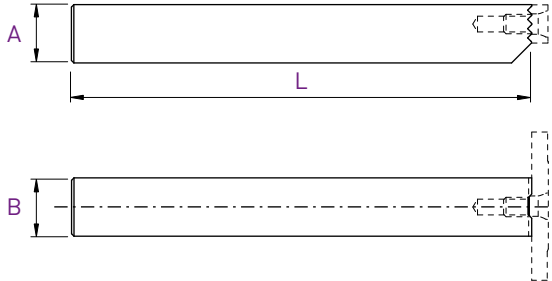

A x B	L	Art. N°
10 x 12	120	260/250F-1012
12 x 12	120	260/250F-1212

Porte-outils

Halter

Holder

## 260/250-D

L/R

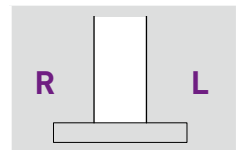
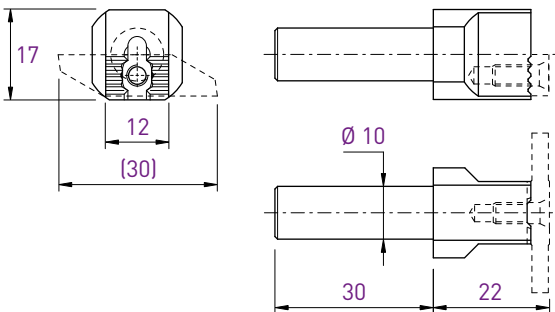

Art. N°
260/250-D10

Chaque support est livré avec vis et clé.  
 Jeder Halter wird mit Spannschraube(n) und Schlüssel geliefert.  
 Screw(s) and key are included with each tool holder.

# ECO-Line

Tronçonnage

Abstechen

Parting off

251 / 261

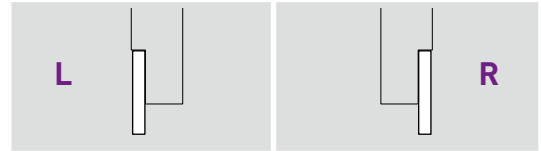
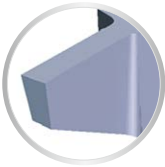
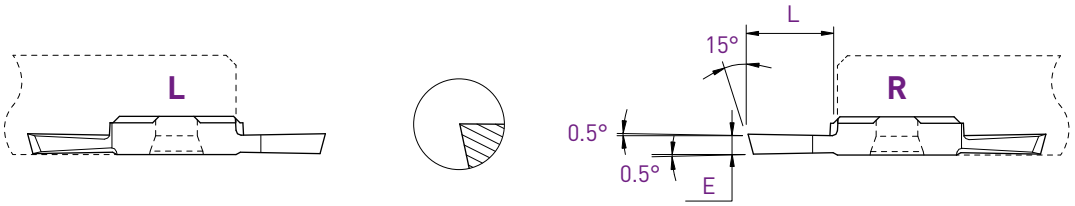

E	L	Art. N°	AP302	AP202	Z	Art. N°	AP302	AP202	Z
0.8	4	251-0.8	■	□	■	261-0.8	■	□	■
1.0	5	251-1.0	■	□	■	261-1.0	■	□	■
1.2	5	251-1.2	■	□	■	261-1.2	■	□	■
1.5	7	251-1.5	■	□	■	261-1.5	■	□	■
2.0	8.5	251-2.0	■	□	■	261-2.0	■	□	■
2.5	8.5	251-2.5	■	□	■	261-2.5	■	□	■

Tronçonnage

Abstechen

Parting off

Coupe déportée

Versetztes Schneiden

Cut off line

261L / 251R

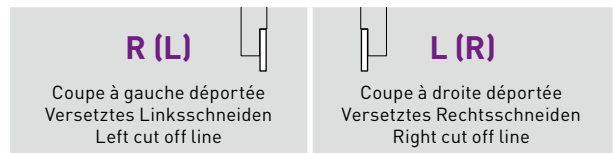
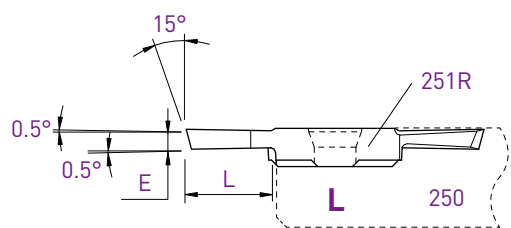
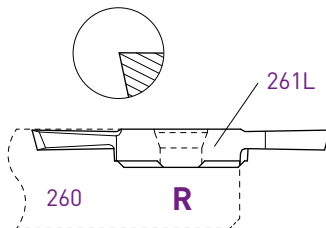
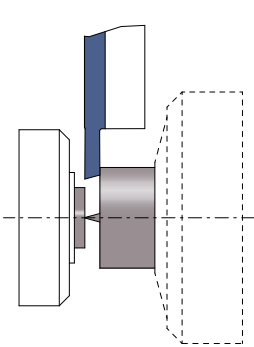

Coupe à gauche déportée  
Versetztes Linksschneiden  
Left cut off line

Coupe à droite déportée  
Versetztes Rechtsschneiden  
Right cut off line

E	L	Art. N°	AP302	AP202	Z	Art. N°	AP302	AP202	Z
1.0	5	-	■	□	■	251R-1.0	■	□	■
1.5	7	-	■	□	■	251R-1.5	■	□	■
2.0	8.5	261L-2.0	■	□	■	251R-2.0	■	□	■



Tronçonnage

Abstechen

Parting off

## 251XF / 261XF

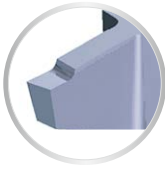
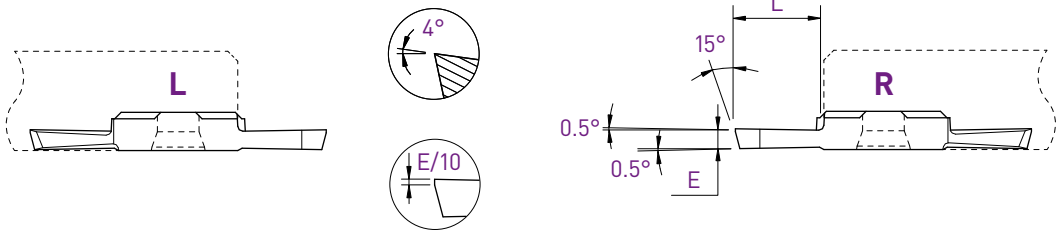

E	L	Art. N°	L			R			
			AP302	AP202	Z	AP302	AP202	Z	
1.5	7	251XF-1.5	■	□	■	261XF-1.5	■	□	■
2.0	8.5	251XF-2.0	■	□	■	261XF-2.0	■	□	■

Tronçonnage

Abstechen

Parting off

Coupe déportée

Versetztes Schneiden

Cut off line

## 251RXF

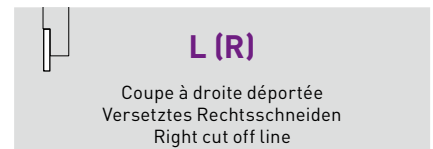
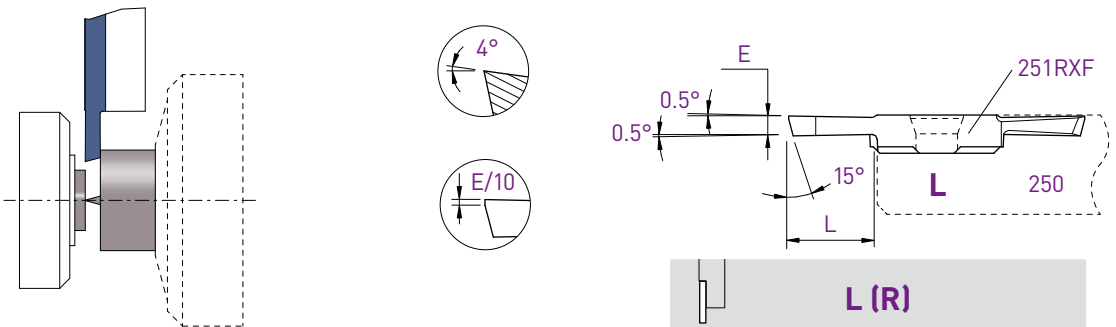

E	L	Art. N°	L (R)		
			AP302	AP202	Z
1.5	7	251RXF-1.5	■	□	■
2.0	8.5	251RXF-2.0	■	□	■

# ECO-Line

Tourneur avant  
Vorwärts drehen  
Front turning

252 / 262



A	Art. N°	AP302	AP202	Z	Art. N°	AP302	AP202	Z
0°	252	■	□	■	262	■	□	■
2°	252-2°	■	□	■	262-2°	■	□	■

Tourneur avant  
Vorwärts drehen  
Front turning

252X / 262X

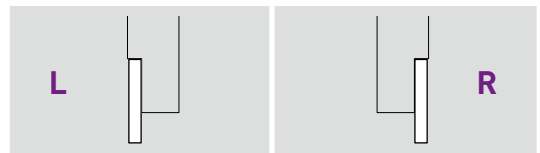
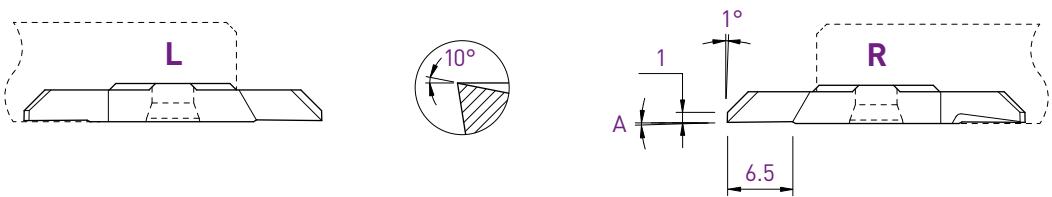

A	Art. N°	AP302	AP202	Z	Art. N°	AP302	AP202	Z
0°	252X	■	□	■	262X	■	□	■
2°	252X-2°	■	□	■	262X-2°	■	□	■



Tourneur avant  
Vorwärts drehen  
Front turning

## 252S / 262S

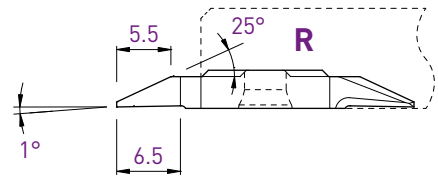
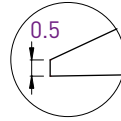
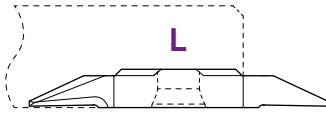

**NEW**

L				R			
Art. N°	AP302	AP202	Z	Art. N°	AP302	AP202	Z
252S05	■	□	■	262S05	■	□	■

Tourneur arrière  
Rückwärts drehen  
Back turning

## 253S / 263S

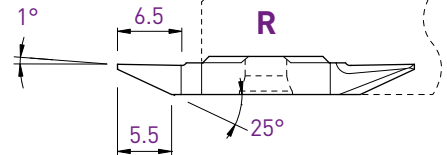
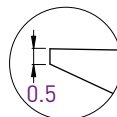
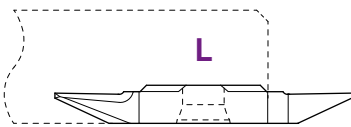

**NEW**

L				R			
Art. N°	AP302	AP202	Z	Art. N°	AP302	AP202	Z
253S05	■	□	■	263S05	■	□	■

# ECO-Line

Tourneur arrière  
Rückwärts drehen  
Back turning

253 / 263

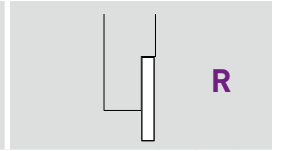
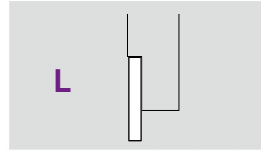
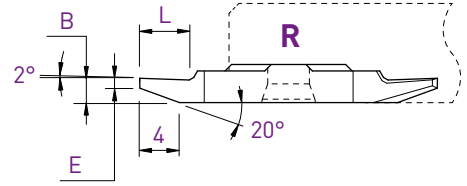
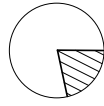
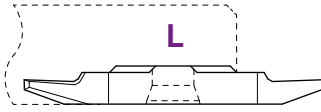

B	E	L	Art. N°	AP302	AP202	Z	Art. N°	AP302	AP202	Z
2.0	0.5	4	253-0.5	■	□	■	263-0.5	■	□	■
2.5	1.0	5	253-1.0	■	□	■	263-1.0	■	□	■

Tourneur arrière  
Rückwärts drehen  
Back turning

253X / 263X

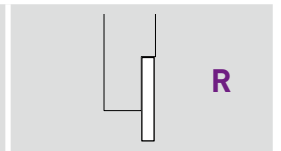
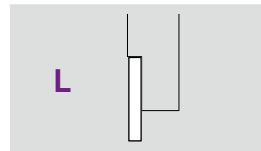
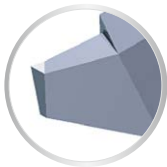
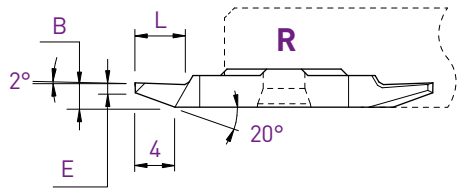
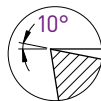
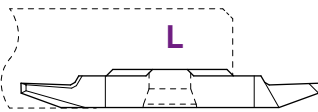

B	E	L	Art. N°	AP302	AP202	Z	Art. N°	AP302	AP202	Z
2.0	0.5	5	253X-0.5	■	□	■	263X-0.5	■	□	■
2.5	1.0	5	253X-1.0	■	□	■	263X-1.0	■	□	■

Tourneur arrière  
Rückwärts drehen  
Back turning

## 253VX-8° / 263VX-8°

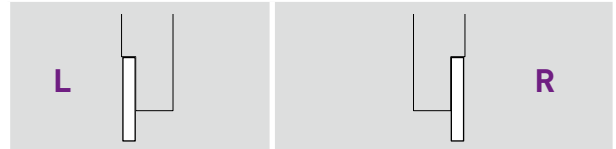
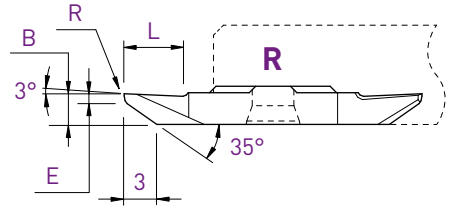
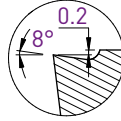
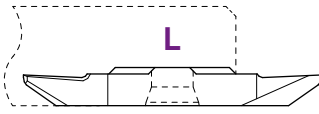

B	E	L	R	Art. N°	AP302	AP202	Z	Art. N°	AP302	AP202	Z	AH302	HN
3.1	1.0	6	0	253VX-8°	■	□	■	263VX-8°	■	□	■		
3.1	1.0	6	0.08	-				263VX-8°-R08	■	□	■	■	■
3.1	1.0	6	0.2	-				263VX-8°-R20	■	□	■	■	■

Tourneur arrière  
Rückwärts drehen  
Back turning

## 253VX-805 / 263VX-805

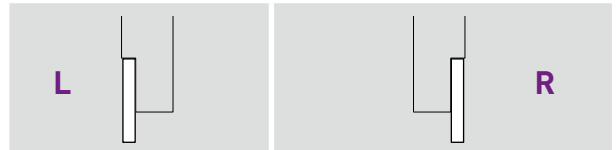
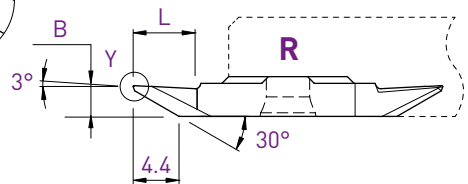
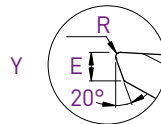
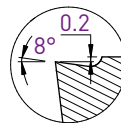
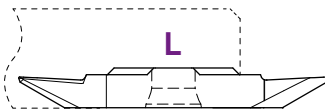

B	E	L	R	Art. N°	AP302	AP202	Z	Art. N°	AP302	AP202	Z	AH302	HN
3.0	0.5	6	0.08	253VX-805-R08	■	□	■	263VX-805-R08	■	□	■	■	■

# ECO-Line

Foncer-tourner

Einstecken und drehen

Grooving and turning

254 / 264

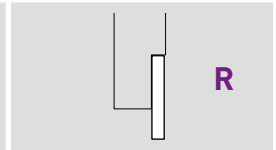
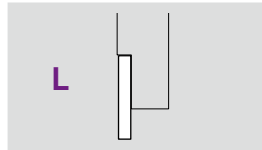
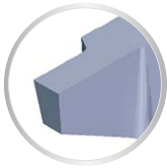
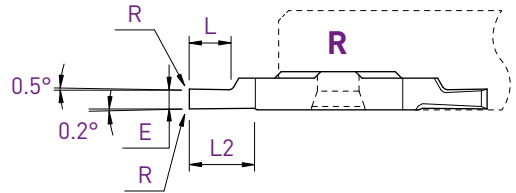
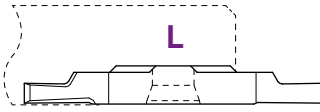

E	L	L2	R	Art. N°	AP302	AP202	Z	Art. N°	AP302	AP202	Z
0.8	2	4	0	254-0.8	■	□	■	264-0.8	■	□	■
1.0	2.5	4	0	254-1.0	■	□	■	264-1.0	■	□	■
1.2	3	4	0	254-1.2	■	□	■	264-1.2	■	□	■
1.5	3	4	0	254-1.5	■	□	■	264-1.5	■	□	■
1.8	4	6.5	0	-				264-1.8	■	□	■
2.0	4	6.5	0	254-2.0	■	□	■	264-2.0	■	□	■
2.5	6	6.5	0	254-2.5	■	□	■	264-2.5	■	□	■
3.0	6.5	6.5	0	254-3.0	■	□	■	264-3.0	■	□	■

Foncer-tourner

Einstecken und drehen

Grooving and turning

## 254X / 264X

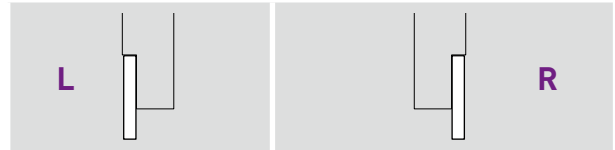
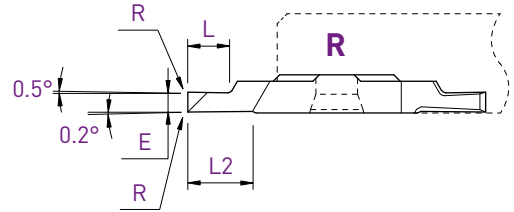
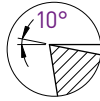
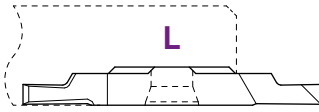

E	L	L2	R	Art. N°	AP302	AP202	Z	Art. N°	AP302	AP202	Z	AH302	HN
0.8	2	4	0	254X-0.8	■	□	■	264X-0.8	■	□	■		
1.0	2.5	4	0	254X-1.0	■	□	■	264X-1.0	■	□	■		
1.0	2.5	4	0.08	-				264X-1.0-R08	■	□	■	■	■
1.2	3	4	0	254X-1.2	■	□	■	264X-1.2	■	□	■		
1.5	3	4	0	254X-1.5	■	□	■	264X-1.5	■	□	■		
1.5	3	4	0.08	-				264X-1.5-R08	■	□	■	■	■
1.5	3	4	0.2	-				264X-1.5-R20	■	□	■	■	■
2.0	4	6.5	0	254X-2.0	■	□	■	264X-2.0	■	□	■		
2.0	4	6.5	0.08	-				264X-2.0-R08	■	□	■	■	■
2.0	4	6.5	0.2	-				264X-2.0-R20	■	□	■	■	■
2.5	6	6.5	0	254X-2.5	■	□	■	264X-2.5	■	□	■		
2.5	6.5	6.5	0.08	-				264X-2.5-R08	■	□	■	■	■
2.5	6.5	6.5	0.2	-				264X-2.5-R20	■	□	■	■	■
3.0	6.5	6.5	0	254X-3.0	■	□	■	264X-3.0	■	□	■		
3.0	6.5	6.5	0.08	-				264X-3.0-R08	■	□	■	■	■
3.0	6.5	6.5	0.2	-				264X-3.0-R20	■	□	■	■	■

# ECO-Line

Fileter

Gewinde drehen

Threading

Partial profile 60°

256-60 / 266-60

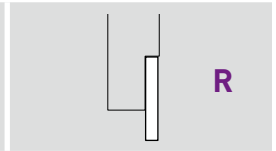
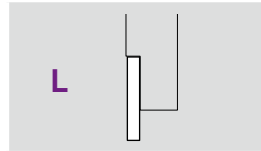
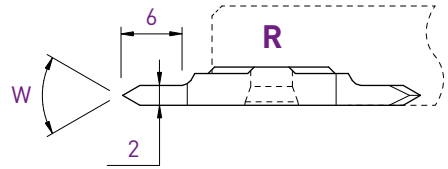
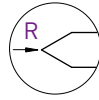
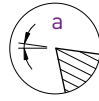
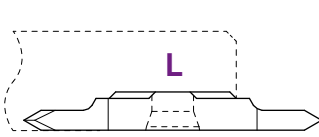

W	R	a	Art. N°	AP302	AP202	Z	Art. N°	AP302	AP202	Z
60°	0	0°	256-60-2	■	□	■	266-60-2	■	□	■
60°	0.06	3°	256-AG60	■	□	■	266-AG60	■	□	■

Fileter

Gewinde drehen

Threading

Partial profile 55°

256-55 / 266-55

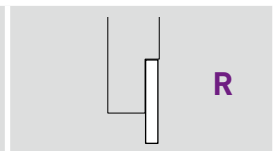
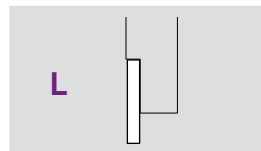
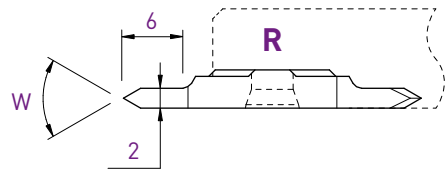
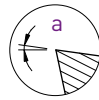
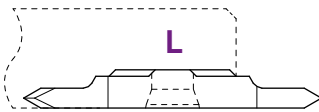

W	R	a	Art. N°	AP302	AP202	Z	Art. N°	AP302	AP202	Z
55°	0	0°	256-55-2	■	□	■	266-55-2	■	□	■
55°	0.06	3°	256-AG55	■	□	■	266-AG55	■	□	■

Plaquette ébauche

WSP-Rohling

Blank insert

251-E / 261-E

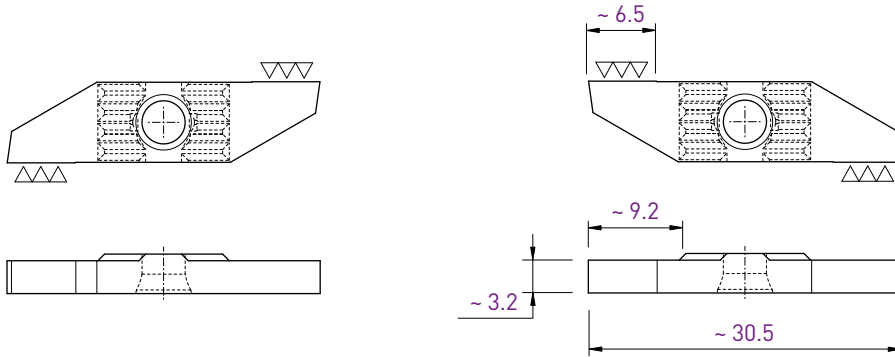

L					R						
Art. N°	AP302	AP202	N	AH302	HN	Art. N°	AP302	AP202	N	AH302	HN
251-E	■	□	■	■	■	261-E	■	□	■	■	■

**ISO-Line**

APPLITEC





Nuances  
Sorten  
Grades

> 4.02

Géométries de coupe  
Spanformgeometrien  
Cutting geometries



> 4.05

Porte-outils et plaquettes 80°  
Halter und WSP 80°  
Holders and inserts 80°



SCA



SCL



SCM

80° > 4.12

Porte-outils et plaquettes 55°  
Halter und WSP 55°  
Holders and inserts 55°



SDA



SDJ



SDN



SDH

55° > 4.18

Porte-outils et plaquettes 35°  
Halter und WSP 35°  
Holders and inserts 35°



SVA



SVJ



SVV



SVX



SV-CL/R

35° > 4.26

Accessoires  
Zubehöre  
Accessories



> 4.36

<p style="text-align: center;"><b>TiALN</b></p> <p style="text-align: center;">revêtement PVD PVD Beschichtung PVD coating</p>	<p style="text-align: center;"><b>TiN</b></p> <p style="text-align: center;">revêtement PVD PVD Beschichtung PVD coating</p>	<p style="text-align: center;"><b>K20</b></p> <p style="text-align: center;">non revêtu unbeschichtet uncoated</p>
<ul style="list-style-type: none"> <li>• nuance universelle</li> <li>• bonne résistance à la température</li> <li>• 1<sup>er</sup> choix pour l'usinage finition des aciers, aciers inoxydables et alliages de titane</li> </ul>	<ul style="list-style-type: none"> <li>• nuance universelle pour travaux légers</li> <li>• très faible coefficient de frottement</li> <li>• 1<sup>er</sup> choix pour l'usinage des matières peu résistantes qui créent des arêtes rapportées</li> <li>• à éviter pour l'usinage du titane</li> </ul>	<ul style="list-style-type: none"> <li>• nuance micro-grain tenace</li> <li>• 1<sup>er</sup> choix comme base pour un revêtement</li> <li>• supporte les coupes interrompues</li> </ul>
<ul style="list-style-type: none"> <li>• Universal-Sorte</li> <li>• sehr gute Warmfestigkeit</li> <li>• für die Bearbeitung von Stahl, rostfreiem Stahl und Titanlegierungen bestens geeignet</li> </ul>	<ul style="list-style-type: none"> <li>• Universal-Sorte für leichte Bearbeitung</li> <li>• sehr geringer Reibwert</li> <li>• für die Bearbeitung von weichen Werkstoffen mit Tendenz zur Bildung von Aufbauschneiden bestens geeignet</li> <li>• für die Bearbeitung von Titan nicht geeignet</li> </ul>	<ul style="list-style-type: none"> <li>• zähe Feinkornsorte</li> <li>• beste Basis für eine Beschichtung</li> <li>• für unterbrochene Schnitte geeignet</li> </ul>
<ul style="list-style-type: none"> <li>• universal grade</li> <li>• good heat resistance</li> <li>• first choice for steel, stainless steel and titanium alloys machining</li> </ul>	<ul style="list-style-type: none"> <li>• universal grade for light machining</li> <li>• very low friction ratio</li> <li>• first choice for low resistance materials which causes edge build-up</li> <li>• not suitable for titanium machining</li> </ul>	<ul style="list-style-type: none"> <li>• tough micro-grain grade</li> <li>• first choice as base for coating</li> <li>• suitable for interrupted cut</li> </ul>
<p style="text-align: center;"><b>HTA</b></p> <p style="text-align: center;">revêtement PVD PVD Beschichtung PVD coating</p>	<p style="text-align: center;"><b>HTiN</b></p> <p style="text-align: center;">revêtement PVD PVD Beschichtung PVD coating</p>	<p style="text-align: center;"><b>K10</b></p> <p style="text-align: center;">non revêtu unbeschichtet uncoated</p>
<ul style="list-style-type: none"> <li>• nuance très résistante à l'usure</li> <li>• très bonne résistance à la température</li> <li>• déconseillé en cas de coupe interrompue et autres conditions d'usinage défavorables</li> </ul>	<ul style="list-style-type: none"> <li>• nuance pour l'usinage den finition des matières peu résistantes qui créent des arêtes rapportées</li> <li>• à éviter pour l'usinage du titane</li> </ul>	<ul style="list-style-type: none"> <li>• nuance micro-grain très résistante à l'usure</li> <li>• recommandé pour l'usinage du titane</li> <li>• déconseillé en cas de coupe interrompue</li> </ul>
<ul style="list-style-type: none"> <li>• sehr verschleißfeste Sorte</li> <li>• sehr gute Warmfestigkeit</li> <li>• für unterbrochene Schnitte und andere ungünstige Bearbeitungsbedingungen nicht geeignet</li> </ul>	<ul style="list-style-type: none"> <li>• Sorte für die Feinbearbeitung von weichen Werkstoffen mit Tendenz zur Bildung von Aufbauschneiden</li> <li>• für die Bearbeitung von Titan nicht geeignet</li> </ul>	<ul style="list-style-type: none"> <li>• verschleißfeste Feinkorn-Sorte</li> <li>• empfehlenswert für Titanbearbeitung</li> <li>• für unterbrochene Schnitte nicht geeignet</li> </ul>
<ul style="list-style-type: none"> <li>• very wear resistant grade</li> <li>• very good heat resistance</li> <li>• not suitable for interrupted cut and other unfavourable machining conditions</li> </ul>	<ul style="list-style-type: none"> <li>• grade for light machining of low resistance materials which causes edge build-up</li> <li>• not suitable for titanium machining</li> </ul>	<ul style="list-style-type: none"> <li>• wear resistant micro-grain grade</li> <li>• suitable for titanium machining</li> <li>• not suitable for interrupted cut</li> </ul>

**Nuances**

**Sorten**

**Grades**

## Tmax

revêtement PVD  
PVD Beschichtung  
PVD coating

- nuance pour l'usinage ébauche et semi-finition des aciers inoxydables
- très faible coefficient de frottement
- résiste aux températures d'usinage élevées

- Sorte für die Bearbeitung von mittlere bis hohe Belastung in rostfreiem Stahl
- sehr geringer Reibwert
- hohe Bearbeitungswarmfestigkeit

- grade for medium to heavy machining of stainless steel
- very low friction ratio
- high machining heat resistance

**NEW**

## TAC

revêtement PVD  
PVD Beschichtung  
PVD coating

- nuance résistante à l'usure pour finition et semi-finition
- 1<sup>er</sup> choix pour les aciers inoxydables et superalliages
- supporte les coupes interrompues

- verschleißfeste Sorte für mittlere bis Schlichtbearbeitung
- für rostfreier Stahl und Superlegierungen bestens geeignet
- für unterbrochene Schnitte geeignet

- wear resistant for finishing and semi-finishing
- first choice for stainless steel and superalloy
- suitable for interrupted cut

**NEW**

## HTAC

revêtement PVD  
PVD Beschichtung  
PVD coating

- nuance très résistante à l'usure pour finition et semi-finition
- 1<sup>er</sup> choix pour les aciers inoxydables et superalliages
- déconseillé en cas de coupe interrompue défavorable

- sehr verschleißfeste Sorte für mittlere bis Schlichtbearbeitung
- für rostfreier Stahl und Superlegierungen bestens geeignet
- für unterbrochene Schnitte nicht geeignet

- very wear resistant for finishing and semi-finishing
- first choice for stainless steel and superalloy
- not suitable for interrupted cut

**NEW**

## Ti4

revêtement CVD  
CVD Beschichtung  
CVD coating

- nuance tenace très polyvalente pour usinage moyen à lourd des aciers et aciers alliés
- résiste aux températures d'usinage élevées

- zähe und vielseitige Sorte für mittlere bis hohe Belastung in Stahl und Stahlegierung
- hohe Bearbeitungswarmfestigkeit

- strong and very versatile grade for medium to heavy machining of steel and alloyed steel
- high machining heat resistance

## Paramètres de coupe indicatifs

## Empfohlene Schnittwerte

## Standard machining data

VC (m/min)	Nuances / Sorten / Grades						
Matière Werkstoff Material	PVD				CVD	Non revêtu Unbeschichtet Uncoated	
	TiALN HTA	TiN HTiN	Tmax	TAC HTAC	Ti4	K10	K20
Acier de décolletage Automatenstahl Free-cutting steel	120 - 200	120 - 180	120 - 220	120 - 200	120 - 250		
Acier Stahl Steel < 600 N/mm <sup>2</sup>	80 - 170	80 - 150	80 - 200	80 - 180	100 - 220		
Acier Stahl Steel < 800 N/mm <sup>2</sup>	60 - 150	60 - 120	60 - 180	60 - 150	100 - 200		
Acier Stahl Steel > 800 N/mm <sup>2</sup>	50 - 120		60 - 150	50 - 120	80 - 180		
Acier inoxydable Rostfreistahl Stainless steel	60 - 140	80 - 120	80 - 160	60 - 150	100 - 200		
Aluminium Si < 12%		250 - 2000				250 - 2000	250 - 1500
Aluminium Si > 12%		250 - 1500		150 - 400		200 - 1500	200 - 1000
Titane Titan Titanium	30 - 80			30 - 70		30 - 70	30 - 60
Cuivre, laiton, bronze Kupfer, Messing, Bronze Copper, brass, bronze		100 - 500		100 - 300		100 - 500	100 - 300

## Conseils d'utilisation

## Anwendungsempfehlungen

## Application recommendations

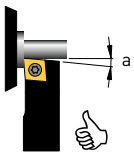

- pour un meilleur état de surface et une meilleure stabilité d'usinage, choisir une géométrie d'outil permettant un angle "a" le plus petit possible

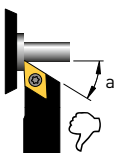

- für bessere Oberflächegüte und Bearbeitungsstabilität, muss die Werkzeuggeometrie mit kleinstmöglichem Winkel "a" ausgewählt werden

- for a better surface finish and better machining stability, choose a tool geometry with angle "a" as small as possible

rapport hauteur de passe / rayon d'outil  
Verhältnis zwischen Spantiefe und Werkzeugradius  
machining depth / tool radius ratio

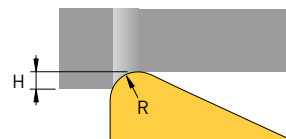

$$H_{\min} = 0.7 \times R$$

$$R_{\max} = 1.4 \times H$$

## Géométries de coupe

## Spanformgeometrien

## Cutting geometries

# FN-X8° / ENP-X8°

### FN-X8°

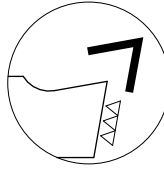
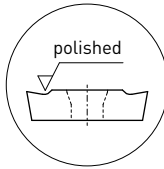

Arête de coupe vive  
Scharfe Schneidkante  
Sharp edge

f [mm/U]

0.01 - 0.15

0.01 - 0.15

0.01 - 0.12

0.01 - 0.18

#### Descriptif

- plaquette polie et rectifiée
- arête de coupe vive
- coupe positive 8° avec maîtrise des copeaux
- nuances micro-grain avec revêtements PVD

#### Beschreibung

- polierte und geschliffene Wendeplatte
- scharfe Schneidkante
- 8° positiver Schnitt mit kontrolliertem Spanbruch
- Feinkornsorten mit PVD-Beschichtungen

#### Description

- polished and ground insert
- sharp cutting edge
- 8° positive cut with controlled chip-breaking
- micrograin grades with PVD coatings

#### Application

- finition
- géométrie universelle pour l'usinage de toutes matières

#### Anwendung

- Schlichtbearbeitung
- allgemeine Geometrie für die Bearbeitung aller Werkstoffe

#### Application

- finishing
- general purpose geometry for the machining of all materials

### ENP-X8°

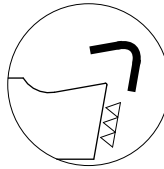
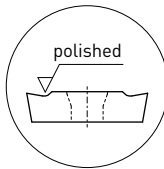

Arête de coupe honée  
Gehonte Schneidkante  
Honed edge

f [mm/U]

0.03 - 0.18

0.03 - 0.18

-

0.03 - 0.20

#### Descriptif

- plaquette polie et rectifiée
- arête de coupe renforcée par polissage
- coupe positive 8° avec maîtrise des copeaux
- nuances micro-grain avec revêtements PVD

#### Beschreibung

- polierte und geschliffene Wendeplatte
- verstärkte und polierte Schneidkante
- 8° positiver Schnitt mit kontrolliertem Spanbruch
- Feinkornsorten mit PVD-Beschichtungen

#### Description

- polished and ground insert
- reinforced and polished cutting edge
- 8° positive cut with controlled chip-breaking
- micrograin grades with PVD coatings

#### Application

- finition et semi-finition
- usinage des aciers et aciers inoxydables

#### Anwendung

- mittlere bis Schlichtbearbeitung
- für die Bearbeitung von Stahl und rostfreiem Stahl

#### Application

- finishing and semi-finishing
- steel and stainless steel machining

### FN-X17°

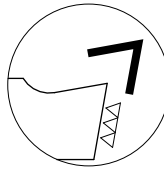
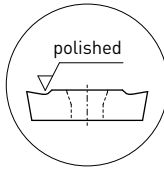

Arête de coupe vive  
Scharfe Schneidkante  
Sharp edge

f [mm/U]

-

0.015 - 0.18

0.015 - 0.15

0.015 - 0.20

#### Descriptif

- plaquette polie et rectifiée
- arête de coupe vive
- coupe positive 17° avec maîtrise des copeaux
- nuances micro-grain avec revêtements PVD

#### Beschreibung

- polierte und geschliffene Wendeplatte
- scharfe Schneidkante
- 17° positiver Schnitt mit kontrolliertem Spanbruch
- Feinkornsorten mit PVD-Beschichtungen

#### Description

- polished and ground insert
- sharp cutting edge
- 17° positive cut with controlled chip-breaking
- micrograin grades with PVD coatings

#### Application

- finition
- usinage des alliages d'aluminium et de titane, des matières non-ferreuses, ainsi que des aciers inoxydables

#### Anwendung

- Schlichtbearbeitung
- Bearbeitung von Aluminium und Titan, Nichteisenmetalle und rostfreiem Stahl

#### Application

- finishing
- machining of aluminium alloys, non-ferrous materials and stainless steel

### ENP-X17°

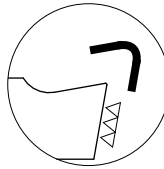
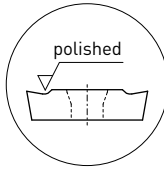

Arête de coupe honée  
Gehonte Schneidkante  
Honed edge

f [mm/U]

0.03 - 0.20

0.03 - 0.20

0.03 - 0.15

0.03 - 0.25

#### Descriptif

- plaquette polie et rectifiée
- arête de coupe renforcée par polissage
- coupe positive 17° avec maîtrise des copeaux
- nuances micro-grain avec revêtements PVD

#### Beschreibung

- polierte und geschliffene Wendeplatte
- verstärkte und polierte Schneidkante
- 17° positiver Schnitt mit kontrolliertem Spanbruch
- Feinkornsorten mit PVD-Beschichtungen

#### Description

- polished and ground insert
- reinforced and polished cutting edge
- 17° positive cut with controlled chip-breaking
- micrograin grades with PVD coatings

#### Application

- finition et semi-finition
- usinage des aciers et aciers inoxydables

#### Anwendung

- mittlere bis Schlichtbearbeitung
- für die Bearbeitung von Stahl und rostfreiem Stahl

#### Application

- finishing and semi-finishing
- steel and stainless steel machining

## Géométries de coupe

## Spanformgeometrien

## Cutting geometries

# FN-X25° / ENP-X25°

### FN-X25°

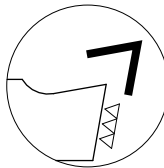
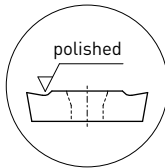

Arête de coupe vive  
Scharfe Schneidkante  
Sharp edge

f [mm/U]

-

0.015 - 0.15

0.015 - 0.15

0.015 - 0.30

#### Descriptif

- plaquette polie et rectifiée
- arête de coupe vive
- coupe positive 25° avec maîtrise des copeaux
- nuances micro-grain avec revêtements PVD

#### Beschreibung

- polierte und geschliffene Wendeplatte
- scharfe Schneidkante
- 25° positiver Schnitt mit kontrolliertem Spanbruch
- Feinkornsorten mit PVD-Beschichtungen

#### Description

- polished and ground insert
- sharp cutting edge
- 25° positive cut with controlled chip-breaking
- micrograin grades with PVD coatings

#### Application

- finition
- usinage des alliages d'aluminium et des matières non-ferreuses, ainsi que des aciers inoxydables

#### Anwendung

- Schlichtbearbeitung
- Bearbeitung von Aluminiumlegierungen, Nichteisenmetalle und rostfreiem Stahl

#### Application

- finishing
- machining of aluminium alloys, non-ferrous materials and stainless steel

### ENP-X25°

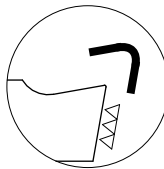
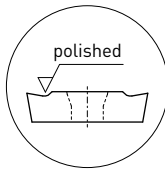

Arête de coupe honée  
Gehonte Schneidkante  
Honed edge

f [mm/U]

-

0.03 - 0.15

0.03 - 0.15

0.03 - 0.30

#### Descriptif

- plaquette polie et rectifiée
- arête de coupe renforcée par polissage
- coupe positive 25° avec maîtrise des copeaux
- nuances micro-grain avec revêtements PVD

#### Beschreibung

- polierte und geschliffene Wendeplatte
- verstärkte und polierte Schneidkante
- 25° positiver Schnitt mit kontrollierte Spanbruch
- Feinkornsorten mit PVD-Beschichtungen

#### Description

- polished and ground insert
- reinforced and polished cutting edge
- 25° positive cut with controlled chip-breaking
- micrograin grades with PVD coatings

#### Application

- finition et semi-finition
- usinage des aciers et aciers inoxydables

#### Anwendung

- mittlere bis Schlichtbearbeitung
- für die Bearbeitung von Stahl und rostfreiem Stahl

#### Application

- finishing and semi-finishing
- steel and stainless steel machining

### FL/FR-X10°

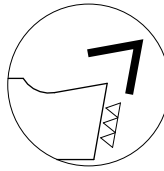
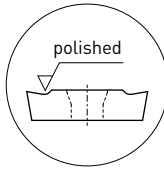

Arête de coupe vive  
Scharfe Schneidkante  
Sharp edge

*disponible uniquement en version 35° type VCGT-1103...  
nur in 35°-Ausführung Typ VCGT-1103... erhältlich  
available only in 35° execution type VCGT-1103*

f [mm/U]

0.015 - 0.12

0.015 - 0.12

0.015 - 0.10

0.015 - 0.15

#### Descriptif

- plaquette polie et rectifiée
- arête de coupe vive
- coupe positive 10° avec maîtrise des copeaux
- nuances micro-grain avec revêtements PVD

#### Beschreibung

- polierte und geschliffene Wendeplatte
- scharfe Schneidkante
- 10° positiver Schnitt mit kontrolliertem Spanbruch
- Feinkornsorten mit PVD - Beschichtungen

#### Description

- polished and ground insert
- sharp cutting edge
- 10° positive cut with controlled chip-breaking
- micrograin grades with PVD coatings

#### Application

- finition
- géométrie universelle pour l'usinage de toutes matières

#### Anwendung

- Schlichtbearbeitung
- allgemeine Geometrie für die Bearbeitung aller Werkstoffe

#### Application

- finishing
- general purpose geometry for the machining of all materials

### ELP/ERP-X10°

**NEW**

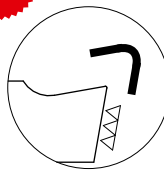
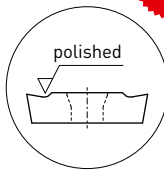

Arête de coupe honée  
Gehonte Schneidkante  
Honed edge

*disponible uniquement en version 35° type VCGT-1103...  
nur in 35°-Ausführung Typ VCGT-1103... erhältlich  
available only in 35° execution type VCGT-1103*

f [mm/U]

0.015 - 0.12

0.015 - 0.12

0.015 - 0.10

0.015 - 0.15

#### Descriptif

- plaquette polie et rectifiée
- arête de coupe renforcée par polissage
- coupe positive 10° avec maîtrise des copeaux
- nuances micro-grain avec revêtements PVD

#### Beschreibung

- polierte und geschliffene Wendeplatte
- verstärkte und polierte Schneidkante
- 10° positiver Schnitt mit kontrolliertem Spanbruch
- Feinkornsorten mit PVD-Beschichtungen

#### Description

- polished and ground insert
- reinforced and polished cutting edge
- 10° positive cut with controlled chip-breaking
- micrograin grades with PVD coatings

#### Application

- finition et semi-finition
- usinage des aciers et aciers inoxydables

#### Anwendung

- mittlere bis Schlichtbearbeitung
- für die Bearbeitung von Stahl und rostfreiem Stahl

#### Application

- finishing and semi-finishing
- steel and stainless steel machining



## Géométries de coupe

## Spanformgeometrien

## Cutting geometries

# FN-K18° / FN-0°

### FN-K18°

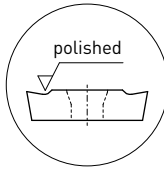
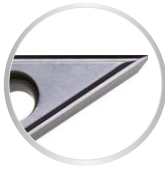

Arête de coupe vive  
Scharfe Schneidkante  
Sharp edge

*disponible uniquement en version 35° type VCGT-1103...  
nur in 35°-Ausführung Typ VCGT-1103... erhältlich  
available only in 35° execution type VCGT-1103*

f [mm/U]

0.01 - 0.10

0.01 - 0.10

0.01 - 0.08

0.01 - 0.15

#### Descriptif

- plaquette polie et rectifiée
- arête de coupe vive
- coupe positive 18° avec maîtrise des copeaux
- nuances micro-grain avec revêtements PVD

#### Beschreibung

- polierte und geschliffene Wendeplatte
- scharfe Schneidkante
- 18° positiver Schnitt mit kontrolliertem Spanbruch
- Feinkornsorten mit PVD-Beschichtungen

#### Description

- polished and ground insert
- sharp cutting edge
- 18° positive cut with controlled chip-breaking
- micrograin grades with PVD coatings

#### Application

- finition
- géométrie universelle pour l'usinage de toutes matières
- avance F = 0.01-0.10 mm / U

#### Anwendung

- Schlichtbearbeitung
- allgemeine Geometrie für die Bearbeitung aller Werkstoffe
- Vorschub F = 0.01-0.10 mm / U

#### Application

- finishing
- general purpose geometry for the machining of all materials
- feed rat F = 0.01-0.10 mm / U

### FN-0°

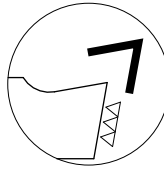
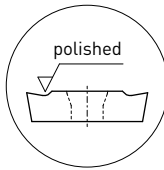

Arête de coupe vive  
Scharfe Schneidkante  
Sharp edge

*disponible uniquement en version 35° type VCGW-1103...  
nur in 35°-Ausführung Typ VCGW-1103... erhältlich  
available only in 35° execution type VCGW-1103*

f [mm/U]

0.01 - 0.10

-

-

0.01 - 0.18

#### Descriptif

- plaquette polie et rectifiée
- arête de coupe vive
- coupe neutre 0°
- nuances micro-grain avec revêtements PVD

#### Beschreibung

- polierte und geschliffene Wendeplatte
- scharfe Schneidkante
- 0° neutraler Schnitt
- Feinkornsorten mit PVD-Beschichtungen

#### Description

- polished and ground insert
- sharp cutting edge
- neutral cut 0°
- micrograin grades with PVD coating

#### Application

- finition
- usinage du laiton

#### Anwendung

- mittlere bis Schlichtbearbeitung
- Messingbearbeitung

#### Application

- finishing and semi-finishing
- brass machining

### EN-XF2

**NEW**

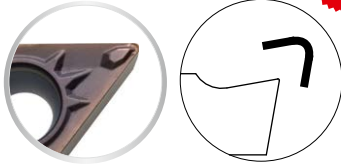

Arête de coupe honée  
Gehonte Schneidkante  
Honed edge

f [mm/U]

0.03 - 0.15

0.03 - 0.15

0.03 - 0.18

0.03 - 0.18

#### Descriptif

- plaquette non rectifiée
- coupe positive avec maîtrise des copeaux
- traitement spécial des arêtes de coupe
- revêtements PVD

#### Application

- finition et semi-finition
- usinage des aciers et acier inoxydables
- très bonne maîtrise du copeau avec des avances faibles et peu de profondeur de passe

#### Beschreibung

- ungeschliffene Wendeplatte
- positiver Schnitt mit kontrolliertem Spanbruch
- Schneidkantenabrundung durch Sonderbehandlungsprozess
- PVD Beschichtungen

#### Anwendung

- mittlere bis Schlichtbearbeitung
- für die Bearbeitung von Stahl und rostfreiem Stahl
- sehr gute Spankontrolle

#### Description

- unground insert
- positive cut with controlled chip-breaking
- special treatment for cutting edge rounding
- PVD coatings

#### Application

- finishing and semi-finishing
- steel and stainless steel machining
- very efficient chip control with low feed rate and small cutting depth

### EN-MF

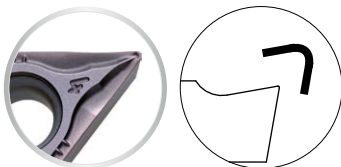

Arête de coupe honée  
Gehonte Schneidkante  
Honed edge

f [mm/U]

0.05 - 0.30

0.05 - 0.25

-

-

#### Descriptif

- plaquette non rectifiée
- coupe positive avec maîtrise des copeaux
- traitement spécial des arêtes de coupe
- revêtements PVD et CVD

#### Application

- travaux moyens
- usinage des aciers et aciers inoxydables

#### Beschreibung

- ungeschliffene Wendeplatte
- positiver Schnitt mit kontrolliertem Spanbruch
- Schneidkantenabrundung durch Sonderbehandlungsprozess
- PVD und CVD Beschichtungen

#### Anwendung

- mittlere Bearbeitung
- für die Bearbeitung von Stahl und rostfreiem Stahl

#### Description

- unground insert
- positive cut with controlled chip-breaking
- special treatment for cutting edge rounding
- PVD and CVD coatings

#### Application

- medium turning
- steel and stainless steel machining

## EN-HF

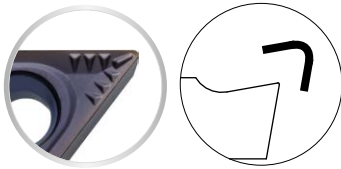

Arête de coupe honée  
Gehonete Schneidkante  
Honed edge

f [mm/U]

0.1 - 0.35

0.1 - 0.30

-

-

**Descriptif**

- plaquette non rectifiée
- coupe positive avec maîtrise des copeaux
- traitement spécial des arêtes de coupe
- revêtement PVD et CVD

**Application**

- semi-finition et finition
- usinage des aciers et acier inoxydables
- excellente finition des aciers au carbone

**Beschreibung**

- ungeschliffene Wendeplatte
- positiver Schnitt mit kontrolliertem Spanbruch
- Schneidkantenabrundung durch Sonderbehandlungsprozess
- PVD und CVD Beschichtung

**Anwendung**

- mittlere bis Schlichtbearbeitung
- für die Bearbeitung von Stahl und rostfreiem Stahl
- sehr effizient für die Oberflächengüte im Kohlenstoffstahl

**Description**

- unground insert
- positive cut with controlled chip-breaking
- special treatment for cutting edge rounding
- PVD and CVD coating

**Application**

- medium turning to semi-finishing
- steel and stainless steel machining
- very efficient surface finish in carbon steel

# ISO-Line

Outils de tournage 80°

80°-Drehwerkzeug

Turning tools 80°

80°



SCA



SCL



SCM

Porte-outils

Halter

Holder

80°

SCA

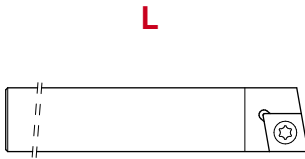

L

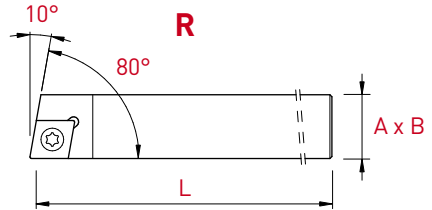

R

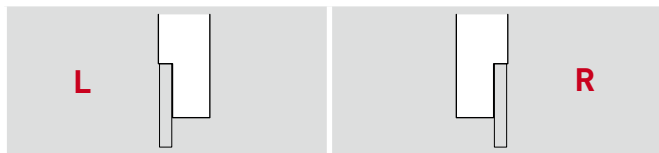

L

R

Plaquette WSP Insert	A x B x L	Old ref.	Art. N°	Old ref.	Art. N°
CC...-0602..	8 x 8 x 115	ISO-2112	<b>SCACL-0808X-06</b>	ISO-2122	<b>SCACR-0808X-06</b>
	10 x 10 x 115	ISO-2113	<b>SCACL-1010X-06</b>	ISO-2123	<b>SCACR-1010X-06</b>
	12 x 12 x 130	ISO-2114	<b>SCACL-1212X-06</b>	ISO-2124	<b>SCACR-1212X-06</b>
	12 x 12 x 90	ISO-2114-90	<b>SCACL-1212G-06</b>	ISO-2124-90	<b>SCACR-1212G-06</b>
	16 x 16 x 130	ISO-2115	<b>SCACL-1616X-06</b>	ISO-2125	<b>SCACR-1616X-06</b>
	16 x 16 x 75	ISO-2115-75	<b>SCACL-1616F-06</b>	ISO-2125-75	<b>SCACR-1616F-06</b>
CC...-09T3..	12 x 12 x 130	ISO-2214	<b>SCACL-1212X-09</b>	ISO-2224	<b>SCACR-1212X-09</b>
	12 x 12 x 90	ISO-2214-90	<b>SCACL-1212G-09</b>	ISO-2224-90	<b>SCACR-1212G-09</b>
	16 x 16 x 130	ISO-2215	<b>SCACL-1616X-09</b>	ISO-2225	<b>SCACR-1616X-09</b>
	16 x 16 x 75	ISO-2215-75	<b>SCACL-1616F-09</b>	ISO-2225-75	<b>SCACR-1616F-09</b>
	20 x 20 x 120	ISO-2216	<b>SCACL-2020X-09</b>	ISO-2226	<b>SCACR-2020X-09</b>

Porte-outils

Halter

Holder

80°

SCL

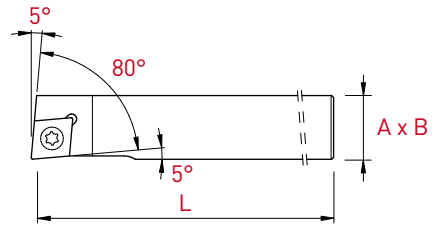
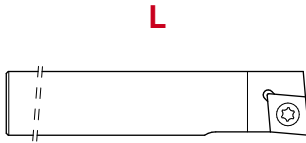

L

R

Plaquette WSP Insert	A x B x L	Old ref.	Art. N°	Old ref.	Art. N°
CC...-0602..	8 x 8 x 115	ISO-2132	<b>SCLCL-0808X-06</b>	ISO-2142	<b>SCLCR-0808X-06</b>
	10 x 10 x 115	ISO-2133	<b>SCLCL-1010X-06</b>	ISO-2143	<b>SCLCR-1010X-06</b>
	12 x 12 x 130	ISO-2134	<b>SCLCL-1212X-06</b>	ISO-2144	<b>SCLCR-1212X-06</b>
	12 x 12 x 90	ISO-2134-90	<b>SCLCL-1212G-06</b>	ISO-2144-90	<b>SCLCR-1212G-06</b>
	16 x 16 x 130	ISO-2135	<b>SCLCL-1616X-06</b>	ISO-2145	<b>SCLCR-1616X-06</b>
	16 x 16 x 75	ISO-2135-75	<b>SCLCL-1616F-06</b>	ISO-2145-75	<b>SCLCR-1616F-06</b>
CC...-09T3..	12 x 12 x 130	ISO-2234	<b>SCLCL-1212X-09</b>	ISO-2244	<b>SCLCR-1212X-09</b>
	12 x 12 x 90	ISO-2234-90	<b>SCLCL-1212G-09</b>	ISO-2244-90	<b>SCLCR-1212G-09</b>
	16 x 16 x 130	ISO-2235	<b>SCLCL-1616X-09</b>	ISO-2245	<b>SCLCR-1616X-09</b>
	16 x 16 x 75	ISO-2235-75	<b>SCLCL-1616F-09</b>	ISO-2245-75	<b>SCLCR-1616F-09</b>
	20 x 20 x 120	ISO-2236	<b>SCLCL-2020X-09</b>	ISO-2246	<b>SCLCR-2020X-09</b>

Porte-outils

Halter

Holder

80°

SCM

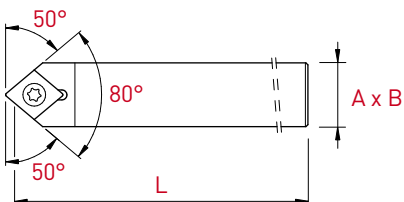

Plaquette WSP Insert	A x B x L	Old ref.	Art. N°
CC...-0602..	8 x 8 x 115	ISO-2102	<b>SCMCN-0808X-06</b>
	10 x 10 x 115	ISO-2103	<b>SCMCN-1010X-06</b>
	12 x 12 x 130	ISO-2104	<b>SCMCN-1212X-06</b>
	12 x 12 x 90	ISO-2104-90	<b>SCMCN-1212G-06</b>
	16 x 16 x 130	ISO-2105	<b>SCMCN-1616X-06</b>
	16 x 16 x 75	ISO-2105-75	<b>SCMCN-1616F-06</b>
CC...-09T3..	12 x 12 x 130	ISO-2204	<b>SCMCN-1212X-09</b>
	12 x 12 x 90	ISO-2204-90	<b>SCMCN-1212G-09</b>
	16 x 16 x 130	ISO-2205	<b>SCMCN-1616X-09</b>
	16 x 16 x 75	ISO-2205-75	<b>SCMCN-1616F-09</b>
	20 x 20 x 120	ISO-2206	<b>SCMCN-2020X-09</b>

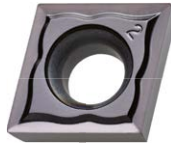

**CCGT  
FN-X8°**

R	Old ref.	Art. N°	PVD		Non revêtu Unbeschichtet Uncoated	PVD		Non revêtu Unbeschichtet Uncoated
			TiAlN	TiN	K20	HTA	K10	
0.05	ISO-1130	<b>CCGT-0602005-FN-X8</b>	■	■	■	■	■	■
0.1	ISO-1131	<b>CCGT-060201-FN-X8</b>	■	■	■	■	■	■
0.2	ISO-1132	<b>CCGT-060202-FN-X8</b>	■	■	■	■	■	■
0.4	ISO-1134	<b>CCGT-060204-FN-X8</b>	■	■	■	■	■	■
0.05	ISO-1230	<b>CCGT-09T3005-FN-X8</b>	■	■	■	■	■	■
0.1	ISO-1231	<b>CCGT-09T301-FN-X8</b>	■	■	■	■	■	■
0.2	ISO-1232	<b>CCGT-09T302-FN-X8</b>	■	■	■	■	■	■
0.4	ISO-1234	<b>CCGT-09T304-FN-X8</b>	■	■	■	■	■	■

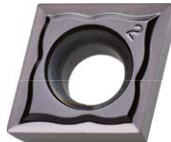

**CCGT  
ENP-X8°**

R	Old ref.	Art. N°	PVD		Non revêtu Unbeschichtet Uncoated	PVD		Non revêtu Unbeschichtet Uncoated
			TiAlN	TiN	K20	HTA	K10	
0.05	ISO-1130-P	<b>CCGT-0602005-ENP-X8</b>	■	■	■			
0.1	ISO-1131-P	<b>CCGT-060201-ENP-X8</b>	■	■	■			
0.2	ISO-1132-P	<b>CCGT-060202-ENP-X8</b>	■	■	■			
0.4	ISO-1134-P	<b>CCGT-060204-ENP-X8</b>	■	■	■			
0.05	ISO-1230-P	<b>CCGT-09T3005-ENP-X8</b>	■	■	■			
0.1	ISO-1231-P	<b>CCGT-09T301-ENP-X8</b>	■	■	■			
0.2	ISO-1232-P	<b>CCGT-09T302-ENP-X8</b>	■	■	■			
0.4	ISO-1234-P	<b>CCGT-09T304-ENP-X8</b>	■	■	■			



Plaquettes en métal dur

VHM-Wendeplatten

Solid carbide inserts

80°

CCGT-X17°



**CCGT  
FN-X17°**

R	Old ref.	Art. N°	PVD		Non revêtu Unbeschichtet Uncoated	PVD		Non revêtu Unbeschichtet Uncoated
			TiAlN	TiN	K20	HTA	K10	
0.05	ISO-1140	CCGT-0602005-FN-X17	■	■	■	■	■	■
0.1	ISO-1141	CCGT-060201-FN-X17	■	■	■	■	■	■
0.2	ISO-1142	CCGT-060202-FN-X17	■	■	■	■	■	■
0.4	ISO-1144	CCGT-060204-FN-X17	■	■	■	■	■	■
0.05	ISO-1240	CCGT-09T3005-FN-X17	■	■	■	■	■	■
0.1	ISO-1241	CCGT-09T301-FN-X17	■	■	■	■	■	■
0.2	ISO-1242	CCGT-09T302-FN-X17	■	■	■	■	■	■
0.4	ISO-1244	CCGT-09T304-FN-X17	■	■	■	■	■	■
0.5	ISO-1248	CCGT-09T308-FN-X17	■	■	■	■	■	■

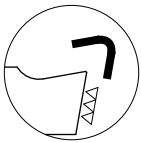

**CCGT  
ENP-X17°**

R	Old ref.	Art. N°	PVD		Non revêtu Unbeschichtet Uncoated	PVD		Non revêtu Unbeschichtet Uncoated
			TiAlN	TiN	K20	HTA	K10	
0.05	ISO-1140-P	CCGT-0602005-ENP-X17	■	■	■			
0.1	ISO-1141-P	CCGT-060201-ENP-X17	■	■	■			
0.2	ISO-1142-P	CCGT-060202-ENP-X17	■	■	■			
0.4	ISO-1144-P	CCGT-060204-ENP-X17	■	■	■			
0.05	ISO-1240-P	CCGT-09T3005-ENP-X17	■	■	■			
0.1	ISO-1241-P	CCGT-09T301-ENP-X17	■	■	■			
0.2	ISO-1242-P	CCGT-09T302-ENP-X17	■	■	■			
0.4	ISO-1244-P	CCGT-09T304-ENP-X17	■	■	■			
0.8	ISO-1248-P	CCGT-09T308-ENP-X17	■	■	■			



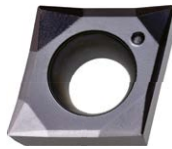

**CCGT  
FN-X25°**

R	Old ref.	Art. N°	PVD		Non revêtu Unbeschichtet Uncoated	PVD		Non revêtu Unbeschichtet Uncoated
			TiAlN	TiN	K20	HTA	K10	
0.05	ISO-1150	CCGT-0602005-FN-X25	■	■	■	■	■	■
0.1	ISO-1151	CCGT-060201-FN-X25	■	■	■	■	■	■
0.2	ISO-1152	CCGT-060202-FN-X25	■	■	■	■	■	■
0.4	ISO-1154	CCGT-060204-FN-X25	■	■	■	■	■	■
0.05	ISO-1250	CCGT-09T3005-FN-X25	■	■	■	■	■	■
0.1	ISO-1251	CCGT-09T301-FN-X25	■	■	■	■	■	■
0.2	ISO-1252	CCGT-09T302-FN-X25	■	■	■	■	■	■
0.4	ISO-1254	CCGT-09T304-FN-X25	■	■	■	■	■	■
0.8	ISO-1258	CCGT-09T308-FN-X25	■	■	■	■	■	■

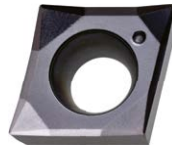

**CCGT  
ENP-X25°**

R	Old ref.	Art. N°	PVD		Non revêtu Unbeschichtet Uncoated	PVD		Non revêtu Unbeschichtet Uncoated
			TiAlN	TiN	K20	HTA	K10	
0.05	ISO-1150-P	CCGT-0602005-ENP-X25	■	■	■			
0.1	ISO-1151-P	CCGT-060201-ENP-X25	■	■	■			
0.2	ISO-1152-P	CCGT-060202-ENP-X25	■	■	■			
0.4	ISO-1154-P	CCGT-060204-ENP-X25	■	■	■			
0.05	ISO-1250-P	CCGT-09T3005-ENP-X25	■	■	■			
0.1	ISO-1251-P	CCGT-09T301-ENP-X25	■	■	■			
0.2	ISO-1252-P	CCGT-09T302-ENP-X25	■	■	■			
0.4	ISO-1254-P	CCGT-09T304-ENP-X25	■	■	■			
0.8	ISO-1258-P	CCGT-09T308-ENP-X25	■	■	■			





Plaquettes en métal dur

VHM-Wendeplatten

Solid carbide inserts

80°

CCMT



**NEW**



**CCMT  
EN-XF2**

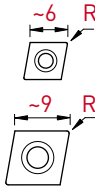

R	Old ref.	Art. N°	PVD		CVD
			Tmax	TAC	HTAC
0.2		CCMT-060202-EN-XF2	■	■	
0.4		CCMT-060204-EN-XF2	■	■	
0.2		CCMT-09T302-EN-XF2	■	■	
0.4		CCMT-09T304-EN-XF2	■	■	



**CCMT  
EN-MF**



R	Old ref.	Art. N°	PVD		CVD
			Tmax	TAC	HTAC
0.2	ISO-1122	CCMT-060202-EN-MF	■		■
0.4	ISO-1124	CCMT-060204-EN-MF	■		■
0.2	ISO-1222	CCMT-09T302-EN-MF	■		■
0.4	ISO-1224	CCMT-09T304-EN-MF	■		■



**CCMT  
EN-HF**

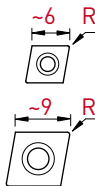

R	Old ref.	Art. N°	PVD		CVD
			Tmax	TAC	HTAC
0.4	ISO-1194	CCMT-060204-EN-HF	■		■
0.8	ISO-1198	CCMT-060208-EN-HF	■		■
0.4	ISO-1294	CCMT-09T304-EN-HF	■		■
0.8	ISO-1298	CCMT-09T308-EN-HF	■		■

# ISO-Line

Outils de tournage 55°

55°-Drehwerkzeuge

Turning tools 55°

55°



SDA



SDJ



SDN

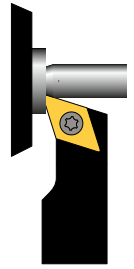

SDH

Porte-outils

Halter

Holder

55°

SDA



L

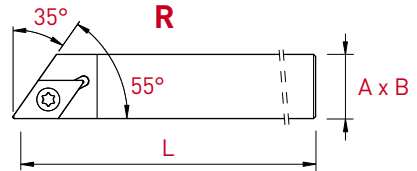

R

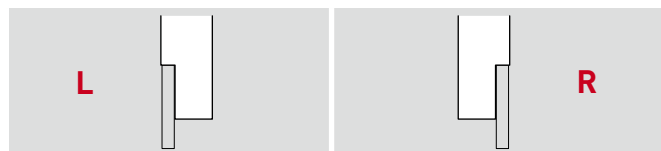

L

R

Plaquette WSP Insert	A x B x L	Old ref.	Art. N°	Old ref.	Art. N°
DC..-0702..	8 x 8 x 115	ISO-2312	<b>SDACL-0808X-07</b>	ISO-2322	<b>SDACR-0808X-07</b>
	10 x 10 x 115	ISO-2313	<b>SDACL-1010X-07</b>	ISO-2323	<b>SDACR-1010X-07</b>
	12 x 12 x 130	ISO-2314	<b>SDACL-1212X-07</b>	ISO-2324	<b>SDACR-1212X-07</b>
	12 x 12 x 90	ISO-2314-90	<b>SDACL-1212G-07</b>	ISO-2324-90	<b>SDACR-1212G-07</b>
	16 x 16 x 130	ISO-2315	<b>SDACL-1616X-07</b>	ISO-2325	<b>SDACR-1616X-07</b>
	16 x 16 x 75	ISO-2315-75	<b>SDACL-1616F-07</b>	ISO-2325-75	<b>SDACR-1616F-07</b>
DC..-11T3..	12 x 12 x 130	ISO-2414	<b>SDACL-1212X-11</b>	ISO-2424	<b>SDACR-1212X-11</b>
	12 x 12 x 90	ISO-2414-90	<b>SDACL-1212G-11</b>	ISO-2424-90	<b>SDACR-1212G-11</b>
	16 x 16 x 130	ISO-2415	<b>SDACL-1616X-11</b>	ISO-2425	<b>SDACR-1616X-11</b>
	16 x 16 x 75	ISO-2415-75	<b>SDACL-1616F-11</b>	ISO-2425-75	<b>SDACR-1616F-11</b>
	20 x 20 x 120	ISO-2416	<b>SDACL-2020X-11</b>	ISO-2426	<b>SDACR-2020X-11</b>

Porte-outils

Halter

Holder's

55°

SDJ

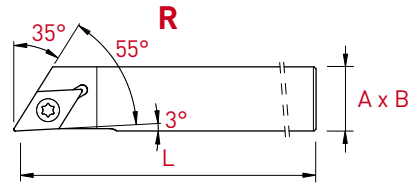

L

R

Plaquette WSP Insert	A x B x L	Old ref.	Art. N°	Old ref.	Art. N°
DC...-0702..	8 x 8 x 115	ISO-2332	<b>SDJCL-0808X-07</b>	ISO-2342	<b>SDJCR-0808X-07</b>
	10 x 10 x 115	ISO-2333	<b>SDJCL-1010X-07</b>	ISO-2343	<b>SDJCR-1010X-07</b>
	12 x 12 x 130	ISO-2334	<b>SDJCL-1212X-07</b>	ISO-2344	<b>SDJCR-1212X-07</b>
	12 x 12 x 90	ISO-2334-90	<b>SDJCL-1212G-07</b>	ISO-2344-90	<b>SDJCR-1212G-07</b>
	16 x 16 x 130	ISO-2335	<b>SDJCL-1616X-07</b>	ISO-2345	<b>SDJCR-1616X-07</b>
	16 x 16 x 75	ISO-2335-75	<b>SDJCL-1616F-07</b>	ISO-2345-75	<b>SDJCR-1616F-07</b>
DC...-11T3..	20 x 20 x 120	ISO-2336	<b>SDJCL-2020X-07</b>	ISO-2346	<b>SDJCR-2020X-07</b>
	12 x 12 x 130	ISO-2434	<b>SDJCL-1212X-11</b>	ISO-2444	<b>SDJCR-1212X-11</b>
	12 x 12 x 90	ISO-2434-90	<b>SDJCL-1212G-11</b>	ISO-2444-90	<b>SDJCR-1212G-11</b>
	16 x 16 x 130	ISO-2435	<b>SDJCL-1616X-11</b>	ISO-2445	<b>SDJCR-1616X-11</b>
	16 x 16 x 75	ISO-2435-75	<b>SDJCL-1616F-11</b>	ISO-2445-75	<b>SDJCR-1616F-11</b>
20 x 20 x 120	ISO-2436	<b>SDJCL-2020X-11</b>	ISO-2446	<b>SDJCR-2020X-11</b>	

Porte-outils

Halter

Holder's

55°

SDN

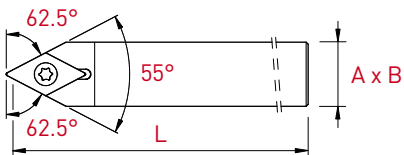

Plaquette WSP Insert	A x B x L	Old ref.	Art. N°
DC...-0702..	8 x 8 x 115	ISO-2302	<b>SDNCN-0808X-07</b>
	10 x 10 x 115	ISO-2303	<b>SDNCN-1010X-07</b>
	12 x 12 x 130	ISO-2304	<b>SDNCN-1212X-07</b>
	12 x 12 x 90	ISO-2304-90	<b>SDNCN-1212G-07</b>
	16 x 16 x 130	ISO-2305	<b>SDNCN-1616X-07</b>
	16 x 16 x 75	ISO-2305-75	<b>SDNCN-1616F-07</b>
DC...-11T3..	12 x 12 x 130	ISO-2404	<b>SDNCN-1212X-11</b>
	12 x 12 x 90	ISO-2404-90	<b>SDNCN-1212G-11</b>
	16 x 16 x 130	ISO-2405	<b>SDNCN-1616X-11</b>
	16 x 16 x 75	ISO-2405-75	<b>SDNCN-1616F-11</b>
	20 x 20 x 120	ISO-2406	<b>SDNCN-2020X-11</b>

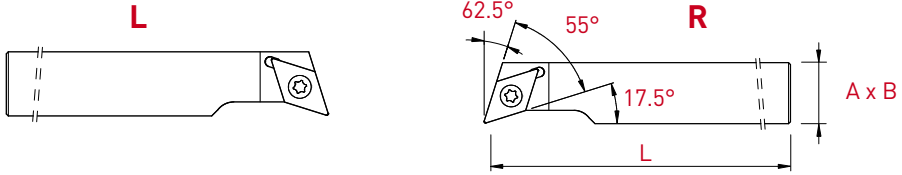

Plaquette WSP Insert	A x B x L	Old ref.	L		R	
			Art. N°	Old ref.	Art. N°	Old ref.
DC...-0702..	10 x 10 x 115	ISO-2353	<b>SDHCL-1010X-07</b>	ISO-2363	<b>SDHCR-1010X-07</b>	
	12 x 12 x 130	ISO-2354	<b>SDHCL-1212X-07</b>	ISO-2364	<b>SDHCR-1212X-07</b>	
	12 x 12 x 90	ISO-2354-90	<b>SDHCL-1212G-07</b>	ISO-2364-90	<b>SDHCR-1212G-07</b>	
	16 x 16 x 130	ISO-2355	<b>SDHCL-1616X-07</b>	ISO-2365	<b>SDHCR-1616X-07</b>	
	16 x 16 x 75	ISO-2355-75	<b>SDHCL-1616F-07</b>	ISO-2365-75	<b>SDHCR-1616F-07</b>	
DC...-11T3..	16 x 16 x 130	ISO-2455	<b>SDHCL-1616X-11</b>	ISO-2465	<b>SDHCR-1616X-11</b>	
	16 x 16 x 75	ISO-2455-75	<b>SDHCL-1616F-11</b>	ISO-2465-75	<b>SDHCR-1616F-11</b>	
	20 x 20 x 120	ISO-2456	<b>SDHCL-2020X-11</b>	ISO-2466	<b>SDHCR-2020X-11</b>	

Porte-outils

Halter

Holder

55°

SDU

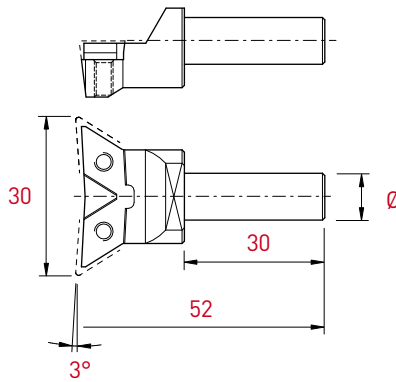

Plaquette WSP Insert	Ø	Old ref.	Art. N°
DC..-11T3..	10	ISO-2400-D10	<b>SDUC-D10X-11</b>

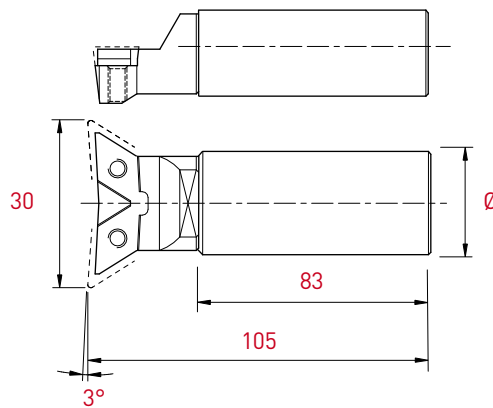

Plaquette WSP Insert	Ø	Old ref.	Art. N°
DC..-11T3..	20	ISO-2400-D20-S	<b>SDUC-D20X-11</b>
	25.4	ISO-2400-D25.4-S	<b>SDUC-D25.4X-11</b>



**DCGT FN-X8°**

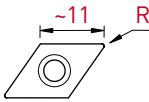
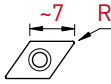

R	Old ref.	Art. N°	PVD		K20	HTA	K10
			TiAlN	TiN			
0.05	ISO-1330	DCGT-0702005-FN-X8	■	■	■	■	■
0.1	ISO-1331	DCGT-070201-FN-X8	■	■	■	■	■
0.2	ISO-1332	DCGT-070202-FN-X8	■	■	■	■	■
0.4	ISO-1334	DCGT-070204-FN-X8	■	■	■	■	■
0.05	ISO-1430	DCGT-11T3005-FN-X8	■	■	■	■	■
0.1	ISO-1431	DCGT-11T301-FN-X8	■	■	■	■	■
0.2	ISO-1432	DCGT-11T302-FN-X8	■	■	■	■	■
0.4	ISO-1434	DCGT-11T304-FN-X8	■	■	■	■	■



**DCGT ENP-X8°**

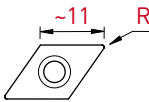
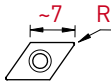

R	Old ref.	Art. N°	PVD		K20	HTA	K10
			TiAlN	TiN			
0.05	ISO-1330-P	DCGT-0702005-ENP-X8	■	■	■		
0.1	ISO-1331-P	DCGT-070201-ENP-X8	■	■	■		
0.2	ISO-1332-P	DCGT-070202-ENP-X8	■	■	■		
0.4	ISO-1334-P	DCGT-070204-ENP-X8	■	■	■		
0.05	ISO-1430-P	DCGT-11T3005-ENP-X8	■	■	■		
0.1	ISO-1431-P	DCGT-11T301-ENP-X8	■	■	■		
0.2	ISO-1432-P	DCGT-11T302-ENP-X8	■	■	■		
0.4	ISO-1434-P	DCGT-11T304-ENP-X8	■	■	■		

Plaquettes en métal dur

VHM-Wendeplatten

Solid carbide inserts

55°

DCGT-X17°



**DCGT  
FN-X17°**

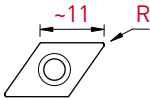
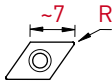

R	Old ref.	Art. N°	PVD		Non revêtu Unbeschichtet Uncoated	PVD		Non revêtu Unbeschichtet Uncoated
			TiALN	TiN	K20	HTA	K10	
0.05	ISO-1340	DCGT-0702005-FN-X17	■	■	■	■	■	■
0.1	ISO-1341	DCGT-070201-FN-X17	■	■	■	■	■	■
0.2	ISO-1342	DCGT-070202-FN-X17	■	■	■	■	■	■
0.4	ISO-1344	DCGT-070204-FN-X17	■	■	■	■	■	■
0.05	ISO-1440	DCGT-11T3005-FN-X17	■	■	■	■	■	■
0.1	ISO-1441	DCGT-11T301-FN-X17	■	■	■	■	■	■
0.2	ISO-1442	DCGT-11T302-FN-X17	■	■	■	■	■	■
0.4	ISO-1444	DCGT-11T304-FN-X17	■	■	■	■	■	■
0.8	ISO-1448	DCGT-11T308-FN-X17	■	■	■	■	■	■



**DCGT  
ENP-X17°**

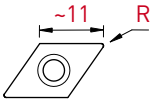
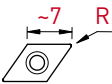

R	Old ref.	Art. N°	PVD		Non revêtu Unbeschichtet Uncoated	PVD		Non revêtu Unbeschichtet Uncoated
			TiALN	TiN	K20	HTA	K10	
0.05	ISO-1340-P	DCGT-0702005-ENP-X17	■	■	■			
0.1	ISO-1341-P	DCGT-070201-ENP-X17	■	■	■			
0.2	ISO-1342-P	DCGT-070202-ENP-X17	■	■	■			
0.4	ISO-1344-P	DCGT-070204-ENP-X17	■	■	■			
0.05	ISO-1440-P	DCGT-11T3005-ENP-X17	■	■	■			
0.1	ISO-1441-P	DCGT-11T301-ENP-X17	■	■	■			
0.2	ISO-1442-P	DCGT-11T302-ENP-X17	■	■	■			
0.4	ISO-1444-P	DCGT-11T304-ENP-X17	■	■	■			
0.8	ISO-1448-P	DCGT-11T308-ENP-X17	■	■	■			

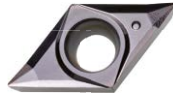

**DCGT  
FN-X25°**

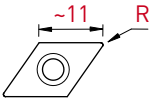
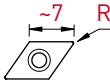

R	Old ref.	Art. N°	PVD		K20	HTA	K10
			TiAlN	TiN			
					Non revêtu Unbeschichtet Uncoated		Non revêtu Unbeschichtet Uncoated
0.05	ISO-1350	DCGT-0702005-FN-X25	■	■	■	■	■
0.1	ISO-1351	DCGT-070201-FN-X25	■	■	■	■	■
0.2	ISO-1352	DCGT-070202-FN-X25	■	■	■	■	■
0.4	ISO-1354	DCGT-070204-FN-X25	■	■	■	■	■
0.05	ISO-1450	DCGT-11T3005-FN-X25	■	■	■	■	■
0.1	ISO-1451	DCGT-11T301-FN-X25	■	■	■	■	■
0.2	ISO-1452	DCGT-11T302-FN-X25	■	■	■	■	■
0.4	ISO-1454	DCGT-11T304-FN-X25	■	■	■	■	■
0.8	ISO-1458	DCGT-11T308-FN-X25	■	■	■	■	■



**DCGT  
ENP-X25°**

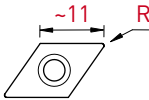
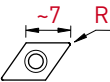

R	Old ref.	Art. N°	PVD		K20	HTA	K10
			TiAlN	TiN			
					Non revêtu Unbeschichtet Uncoated		Non revêtu Unbeschichtet Uncoated
0.05	ISO-1350-P	DCGT-0702005-ENP-X25	■	■	■		
0.1	ISO-1351-P	DCGT-070201-ENP-X25	■	■	■		
0.2	ISO-1352-P	DCGT-070202-ENP-X25	■	■	■		
0.4	ISO-1354-P	DCGT-070204-ENP-X25	■	■	■		
0.05	ISO-1450-P	DCGT-11T3005-ENP-X25	■	■	■		
0.1	ISO-1451-P	DCGT-11T301-ENP-X25	■	■	■		
0.2	ISO-1452-P	DCGT-11T302-ENP-X25	■	■	■		
0.4	ISO-1454-P	DCGT-11T304-ENP-X25	■	■	■		
0.8	ISO-1458-P	DCGT-11T308-ENP-X25	■	■	■		



Plaquettes en métal dur

VHM-Wendeplatten

Solid carbide inserts

55°

DCMT



**NEW**

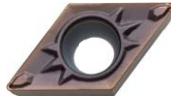

**DCMT  
EN-XF2**

R	Old ref.	Art. N°	PVD			CVD
			Tmax	TAC	HTAC	Ti4
0.2		DCMT-070202-EN-XF2	■	■		
0.4		DCMT-070204-EN-XF2	■	■		
0.2		DCMT-11T302-EN-XF2		■	■	
0.4		DCMT-11T304-EN-XF2		■	■	

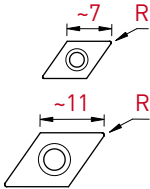

**DCMT  
EN-MF**

R	Old ref.	Art. N°	PVD			CVD
			Tmax	TAC	HTAC	Ti4
0.2	ISO-1322	DCMT-070202-EN-MF	■			■
0.4	ISO-1324	DCMT-070204-EN-MF	■			■
0.2	ISO-1422	DCMT-11T302-EN-MF		■	■	■
0.4	ISO-1424	DCMT-11T304-EN-MF		■	■	■

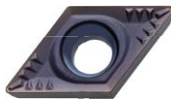
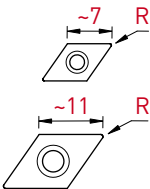

**DCMT  
EN-HF**

R	Old ref.	Art. N°	PVD			CVD
			Tmax	TAC	HTAC	Ti4
0.4	ISO-1394	DCMT-070204-EN-HF	■			■
0.8	ISO-1398	DCMT-070208-EN-HF	■			■
0.4	ISO-1494	DCMT-11T304-EN-HF		■	■	■
0.8	ISO-1498	DCMT-11T308-EN-HF		■	■	■

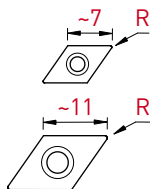

# ISO-Line

Outils de tournage 35°

35°-Drehwerkzeuge

Turning tools 35°

35°

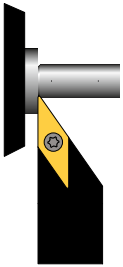

SVA



SVJ



SWV



SVX

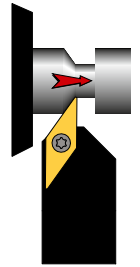

SV-CL/R

Porte-outils

Halter

Holder

35°

SVA

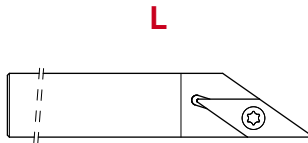

L

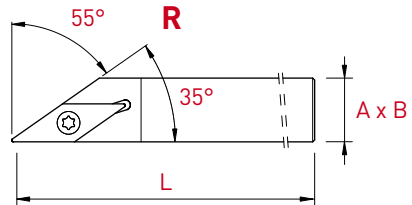

R

A x B

L

L

R

Plaquette WSP Insert	A x B x L	Old ref.	Art. N°	Old ref.	Art. N°
VC...-1103..	8 x 8 x 115	ISO-2612	<b>SVACL-0808X-11</b>	ISO-2622	<b>SVACR-0808X-11</b>
	10 x 10 x 115	ISO-2613	<b>SVACL-1010X-11</b>	ISO-2623	<b>SVACR-1010X-11</b>
	12 x 12 x 130	ISO-2614	<b>SVACL-1212X-11</b>	ISO-2624	<b>SVACR-1212X-11</b>
	12 x 12 x 90	ISO-2614-90	<b>SVACL-1212G-11</b>	ISO-2624-90	<b>SVACR-1212G-11</b>
	16 x 16 x 130	ISO-2615	<b>SVACL-1616X-11</b>	ISO-2625	<b>SVACR-1616X-11</b>
	16 x 16 x 75	ISO-2615-75	<b>SVACL-1616F-11</b>	ISO-2625-75	<b>SVACR-1616F-11</b>
VC...-1604..	20 x 20 x 120	ISO-2616	<b>SVACL-2020X-11</b>	ISO-2626	<b>SVACR-2020X-11</b>
	12 x 12 x 130	ISO-2714	<b>SVACL-1212X-16</b>	ISO-2724	<b>SVACR-1212X-16</b>
	12 x 12 x 90	ISO-2714-90	<b>SVACL-1212G-16</b>	ISO-2724-90	<b>SVACR-1212G-16</b>
	16 x 16 x 130	ISO-2715	<b>SVACL-1616X-16</b>	ISO-2725	<b>SVACR-1616X-16</b>
	16 x 16 x 75	ISO-2715-75	<b>SVACL-1616F-16</b>	ISO-2725-75	<b>SVACR-1616F-16</b>
20 x 20 x 120	ISO-2716	<b>SVACL-2020X-16</b>	ISO-2726	<b>SVACR-2020X-16</b>	

Porte-outils

Halter

Holder's

35°

SVJ

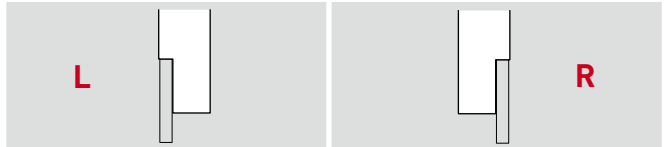
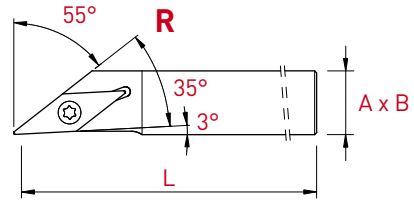
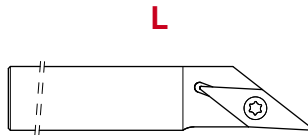

Plaquette WSP Insert	A x B x L	Old ref.	Art. N°	Old ref.	Art. N°
VC...1103..	8 x 8 x 115	ISO-2632	<b>SVJCL-0808X-11</b>	ISO-2642	<b>SVJCR-0808X-11</b>
	10 x 10 x 115	ISO-2633	<b>SVJCL-1010X-11</b>	ISO-2643	<b>SVJCR-1010X-11</b>
	12 x 12 x 130	ISO-2634	<b>SVJCL-1212X-11</b>	ISO-2644	<b>SVJCR-1212X-11</b>
	12 x 12 x 90	ISO-2634-90	<b>SVJCL-1212G-11</b>	ISO-2644-90	<b>SVJCR-1212G-11</b>
	16 x 16 x 130	ISO-2635	<b>SVJCL-1616X-11</b>	ISO-2645	<b>SVJCR-1616X-11</b>
	16 x 16 x 75	ISO-2635-75	<b>SVJCL-1616F-11</b>	ISO-2645-75	<b>SVJCR-1616F-11</b>
VC...1604..	20 x 20 x 120	ISO-2636	<b>SVJCL-2020X-11</b>	ISO-2646	<b>SVJCR-2020X-11</b>
	12 x 12 x 130	ISO-2734	<b>SVJCL-1212X-16</b>	ISO-2744	<b>SVJCR-1212X-16</b>
	12 x 12 x 90	ISO-2734-90	<b>SVJCL-1212G-16</b>	ISO-2744-90	<b>SVJCR-1212G-16</b>
	16 x 16 x 130	ISO-2735	<b>SVJCL-1616X-16</b>	ISO-2745	<b>SVJCR-1616X-16</b>
	16 x 16 x 75	ISO-2735-75	<b>SVJCL-1616F-16</b>	ISO-2745-75	<b>SVJCR-1616F-16</b>
20 x 20 x 120	ISO-2736	<b>SVJCL-2020X-16</b>	ISO-2746	<b>SVJCR-2020X-16</b>	

Porte-outils

Halter

Holder's

35°

SVV

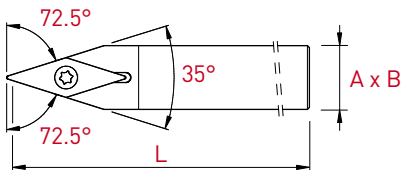

Plaquette WSP Insert	A x B x L	Old ref.	Art. N°
VC...1103..	8 x 8 x 115	ISO-2602	<b>SVVCN-0808X-11</b>
	10 x 10 x 115	ISO-2603	<b>SVVCN-1010X-11</b>
	12 x 12 x 130	ISO-2604	<b>SVVCN-1212X-11</b>
	12 x 12 x 90	ISO-2604-90	<b>SVVCN-1212G-11</b>
	16 x 16 x 130	ISO-2605	<b>SVVCN-1616X-11</b>
	16 x 16 x 75	ISO-2605-75	<b>SVVCN-1616F-11</b>
VC...1604..	20 x 20 x 120	ISO-2606	<b>SVVCN-2020X-11</b>
	12 x 12 x 130	ISO-2704	<b>SVVCN-1212X-16</b>
	12 x 12 x 90	ISO-2704-90	<b>SVVCN-1212G-16</b>
	16 x 16 x 130	ISO-2705	<b>SVVCN-1616X-16</b>
	16 x 16 x 75	ISO-2705-75	<b>SVVCN-1616F-16</b>
20 x 20 x 120	ISO-2706	<b>SVVCN-2020X-16</b>	

# ISO-Line

Porte-outils

Halter

Holder's

35°

SVX

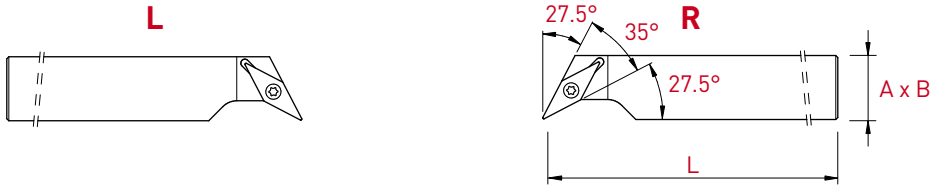

Plaquette WSP Insert	A x B x L	Old ref.	Art. N°	Old ref.	Art. N°
	16 x 16 x 130	ISO-2655	<b>SVXCL-1616X-11</b>	ISO-2665	<b>SVXCR-1616X-11</b>
VC..-1103..	16 x 16 x 75	ISO-2655-75	<b>SVXCL-1616F-11</b>	ISO-2665-75	<b>SVXCR-1616F-11</b>
	20 x 20 x 120	ISO-2656	<b>SVXCL-2020X-11</b>	ISO-2666	<b>SVXCR-2020X-11</b>

Porte-outils

Halter

Holder's

35°

SV-CL/R

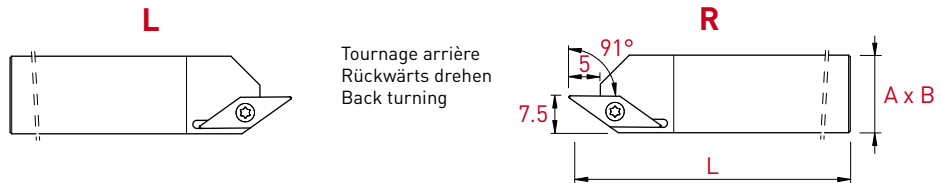

Plaquette WSP Insert	A x B x L	Old ref.	Art. N°	Old ref.	Art. N°
	12 x 12 x 130	ISO-2674	<b>SV-CL-1212X-11</b>	ISO-2684	<b>SV-CR-1212X-11</b>
	12 x 12 x 90	ISO-2674-90	<b>SV-CL-1212G-11</b>	ISO-2684-90	<b>SV-CR-1212G-11</b>
VC..-1103..	16 x 16 x 130	ISO-2675	<b>SV-CL-1616X-11</b>	ISO-2685	<b>SV-CR-1616X-11</b>
	16 x 16 x 75	ISO-2675-75	<b>SV-CL-1616F-11</b>	ISO-2685-75	<b>SV-CR-1616F-11</b>
	20 x 20 x 120	ISO-2676	<b>SV-CL-2020X-11</b>	ISO-2686	<b>SV-CR-2020X-11</b>

Porte-outils compatibles avec plaquettes VCGT FL/FR-X10°

Passende Halter zu den Wendepplatten VCGT FL/FR-X10°

Holder compatible with inserts VCGT FL/FR-X10°

35°

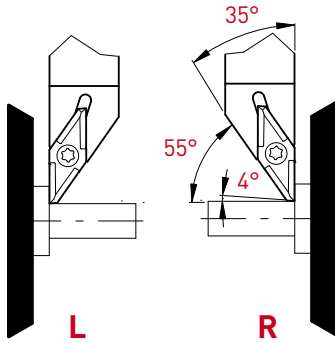

	Old ref.	Art. N°
<b>R</b>	ISO-262x	<b>SVACR-...-11</b>
<b>L</b>	ISO-261x	<b>SVACL-...-11</b>

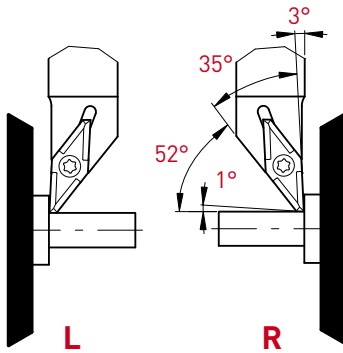

	Old ref.	Art. N°
<b>R</b>	ISO-264x	<b>SVJCR-...-11</b>
<b>L</b>	ISO-263x	<b>SVJCL-...-11</b>

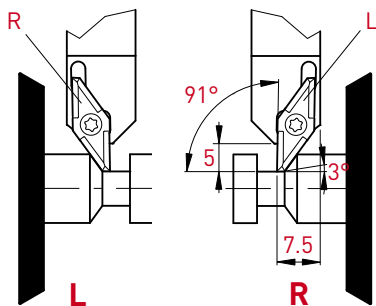

	Old ref.	Art. N°
<b>R</b>	ISO-268x	<b>SV-CR-...-11</b>
<b>L</b>	ISO-267x	<b>SV-CL-...-11</b>

# ISO-Line

Plaquettes en métal dur

VHM-Wendeplatten

Solid carbide inserts

35°

VCGT-FL / FR-X10°



**VCGT  
FL / FR-X10°**

R	Old ref.	Art. N°	PVD		Non revêtu Unbeschichtet Uncoated	PVD		Non revêtu Unbeschichtet Uncoated
			TiAlN	TiN	K20	HTA	K10	
0.03	ISO-1690-R	<b>VCGT-1103003-FR-X10</b>	■	■	■	■	■	■
0.08	ISO-16908-R	<b>VCGT-1103008-FR-X10</b>	■	■	■	■	■	■
0.1	ISO-1691-R	<b>VCGT-110301-FR-X10</b>	■	■	■	■	■	■
0.2	ISO-1692-R	<b>VCGT-110302-FR-X10</b>	■	■	■	■	■	■
0.03	ISO-1690-L	<b>VCGT-1103003-FL-X10</b>	■	■	■	■	■	■
0.08	ISO-16908-L	<b>VCGT-1103008-FL-X10</b>	■	■	■	■	■	■
0.1	ISO-1691-L	<b>VCGT-110301-FL-X10</b>	■	■	■	■	■	■
0.2	ISO-1692-L	<b>VCGT-110302-FL-X10</b>	■	■	■	■	■	■

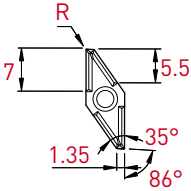

**R**



**L**

Plaquettes en métal dur

VHM-Wendeplatten

Solid carbide inserts

35°

VCGT-ELP / ERP-X10°



**NEW**



**VCGT  
ELP/ERP-X10°**

R	Old ref.	Art. N°	PVD		Non revêtu Unbeschichtet Uncoated	PVD		Non revêtu Unbeschichtet Uncoated
			TiAlN	TiN	K20	HTA	K10	
0.03		<b>VCGT-1103003-ERP-X10</b>	■	■	■	■	■	■
0.08		<b>VCGT-1103008-ERP-X10</b>	■	■	■	■	■	■
0.1		<b>VCGT-110301-ERP-X10</b>	■	■	■	■	■	■
0.2		<b>VCGT-110302-ERP-X10</b>	■	■	■	■	■	■
0.03		<b>VCGT-1103003-ELP-X10</b>	■	■	■	■	■	■
0.08		<b>VCGT-1103008-ELP-X10</b>	■	■	■	■	■	■
0.1		<b>VCGT-110301-ELP-X10</b>	■	■	■	■	■	■
0.2		<b>VCGT-110302-ELP-X10</b>	■	■	■	■	■	■

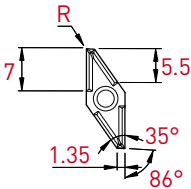

**R**



**L**

Plaquettes en métal dur

VHM-Wendeplatten

Solid carbide inserts

35°

VCGT



**VCGT  
FN-K18°**

PVD

Non revêtu  
Unbeschichtet  
Uncoated

R	Old ref.	Art. N°	HTA	HTIN	K10
0.05	ISO-1680	VCGT-1103005-FN-K18	■	■	■
0.1	ISO-1681	VCGT-110301-FN-K18	■	■	■
0.2	ISO-1682	VCGT-110302-FN-K18	■	■	■
0.4	ISO-1684	VCGT-110304-FN-K18	■	■	■

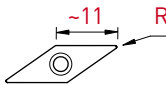

**VCGW-0°**

PVD

Non revêtu  
Unbeschichtet  
Uncoated

R	Old ref.	Art. N°	HTA	HTIN	K10
0.05	ISO-1670	VCGW-1103005-FN-0	■	■	■
0.1	ISO-1671	VCGW-110301-FN-0	■	■	■
0.2	ISO-1672	VCGW-110302-FN-0	■	■	■
0.4	ISO-1674	VCGW-110304-FN-0	■	■	■

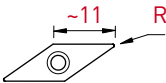

# ISO-Line

Plaquettes en métal dur

VHM-Wendeplatten

Solid carbide inserts

35°

VCGT-X8°



**VCGT  
FN-X8°**

R	Old ref.	Art. N°	PVD		K20	PVD	
			TiALN	TiN		HTA	K10
						Non revêtu Unbeschichtet	Non revêtu Unbeschichtet
0.05	ISO-1630	<b>VCGT-1103005-FN-X8</b>	■	■	■	■	■
0.1	ISO-1631	<b>VCGT-110301-FN-X8</b>	■	■	■	■	■
0.2	ISO-1632	<b>VCGT-110302-FN-X8</b>	■	■	■	■	■
0.4	ISO-1634	<b>VCGT-110304-FN-X8</b>	■	■	■	■	■
0.05	ISO-1730	<b>VCGT-1604005-FN-X8</b>	■	■	■	■	■
0.1	ISO-1731	<b>VCGT-160401-FN-X8</b>	■	■	■	■	■
0.2	ISO-1732	<b>VCGT-160402-FN-X8</b>	■	■	■	■	■
0.4	ISO-1734	<b>VCGT-160404-FN-X8</b>	■	■	■	■	■

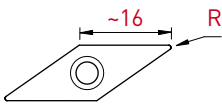
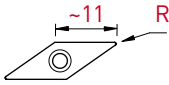

**VCGT  
ENP-X8°**

R	Old ref.	Art. N°	PVD		K20	PVD	
			TiALN	TiN		HTA	K10
						Non revêtu Unbeschichtet	Non revêtu Unbeschichtet
0.05	ISO-1630-P	<b>VCGT-1103005-ENP-X8</b>	■	■	■		
0.1	ISO-1631-P	<b>VCGT-110301-ENP-X8</b>	■	■	■		
0.2	ISO-1632-P	<b>VCGT-110302-ENP-X8</b>	■	■	■		
0.4	ISO-1634-P	<b>VCGT-110304-ENP-X8</b>	■	■	■		
0.05	ISO-1730-P	<b>VCGT-1604005-ENP-X8</b>	■	■	■		
0.1	ISO-1731-P	<b>VCGT-160401-ENP-X8</b>	■	■	■		
0.2	ISO-1732-P	<b>VCGT-160402-ENP-X8</b>	■	■	■		
0.4	ISO-1734-P	<b>VCGT-160404-ENP-X8</b>	■	■	■		

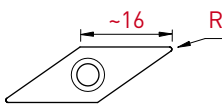
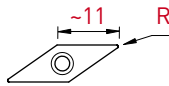



Plaquettes en métal dur

VHM-Wendeplatten

Solid carbide inserts

35°

VCGT-X17°



**VCGT  
FN-X17°**

R	Old ref.	Art. N°	PVD		Non revêtu Unbeschichtet Uncoated	PVD		Non revêtu Unbeschichtet Uncoated
			TiAlN	TiN	K20	HTA	K10	
0.05	ISO-1640	VCGT-1103005-FN-X17	■	■	■	■	■	■
0.1	ISO-1641	VCGT-110301-FN-X17	■	■	■	■	■	■
0.2	ISO-1642	VCGT-110302-FN-X17	■	■	■	■	■	■
0.4	ISO-1644	VCGT-110304-FN-X17	■	■	■	■	■	■
0.05	ISO-1740	VCGT-1604005-FN-X17	■	■	■	■	■	■
0.1	ISO-1741	VCGT-160401-FN-X17	■	■	■	■	■	■
0.2	ISO-1742	VCGT-160402-FN-X17	■	■	■	■	■	■
0.4	ISO-1744	VCGT-160404-FN-X17	■	■	■	■	■	■
0.8	ISO-1748	VCGT-160408-FN-X17	■	■	■	■	■	■

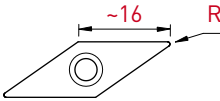
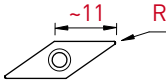

**VCGT  
ENP-X17°**

R	Old ref.	Art. N°	PVD		Non revêtu Unbeschichtet Uncoated	PVD		Non revêtu Unbeschichtet Uncoated
			TiAlN	TiN	K20	HTA	K10	
0.05	ISO-1640-P	VCGT-1103005-ENP-X17	■	■	■			
0.1	ISO-1641-P	VCGT-110301-ENP-X17	■	■	■			
0.2	ISO-1642-P	VCGT-110302-ENP-X17	■	■	■			
0.4	ISO-1644-P	VCGT-110304-ENP-X17	■	■	■			
0.05	ISO-1740-P	VCGT-1604005-ENP-X17	■	■	■			
0.1	ISO-1741-P	VCGT-160401-ENP-X17	■	■	■			
0.2	ISO-1742-P	VCGT-160402-ENP-X17	■	■	■			
0.4	ISO-1744-P	VCGT-160404-ENP-X17	■	■	■			
0.8	ISO-1748-P	VCGT-160408-ENP-X17	■	■	■			

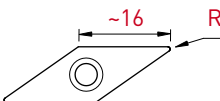
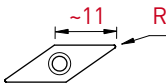



R	Old ref.	Art. N°	PVD		Non revêtu Unbeschichtet Uncoated	PVD		Non revêtu Unbeschichtet Uncoated
			TiALN	TiN	K20	HTA	K10	
0.05	ISO-1650	VCGT-1103005-FN-X25	■	■	■	■	■	■
0.1	ISO-1651	VCGT-110301-FN-X25	■	■	■	■	■	■
0.2	ISO-1652	VCGT-110302-FN-X25	■	■	■	■	■	■
0.4	ISO-1654	VCGT-110304-FN-X25	■	■	■	■	■	■
0.05	ISO-1750	VCGT-1604005-FN-X25	■	■	■	■	■	■
0.1	ISO-1751	VCGT-160401-FN-X25	■	■	■	■	■	■
0.2	ISO-1752	VCGT-160402-FN-X25	■	■	■	■	■	■
0.4	ISO-1754	VCGT-160404-FN-X25	■	■	■	■	■	■
0.8	ISO-1758	VCGT-160408-FN-X25	■	■	■	■	■	■

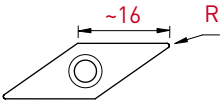
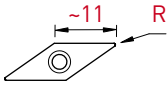

R	Old ref.	Art. N°	PVD		Non revêtu Unbeschichtet Uncoated	PVD		Non revêtu Unbeschichtet Uncoated
			TiALN	TiN	K20	HTA	K10	
0.05	ISO-1650-P	VCGT-1103005-ENP-X25	■	■	■			
0.1	ISO-1651-P	VCGT-110301-ENP-X25	■	■	■			
0.2	ISO-1652-P	VCGT-110302-ENP-X25	■	■	■			
0.4	ISO-1654-P	VCGT-110304-ENP-X25	■	■	■			
0.05	ISO-1750-P	VCGT-1604005-ENP-X25	■	■	■			
0.1	ISO-1751-P	VCGT-160401-ENP-X25	■	■	■			
0.2	ISO-1752-P	VCGT-160402-ENP-X25	■	■	■			
0.4	ISO-1754-P	VCGT-160404-ENP-X25	■	■	■			
0.8	ISO-1758-P	VCGT-160408-ENP-X25	■	■	■			

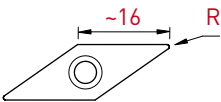
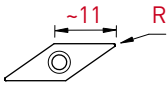

Plaquettes en métal dur

VHM-Wendeplatten

Solid carbide inserts

35°

VCMT

**NEW**



**VCMT  
EN-XF2**

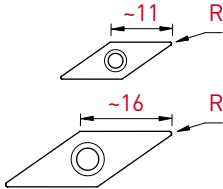

R	Old ref.	Art. N°	PVD			CVD
			Tmax	TAC	HTAC	Ti4
0.2		VCMT-110302-EN-XF2	■	■		
0.4		VCMT-110304-EN-XF2	■	■		
0.4		VCMT-160404-EN-XF2	■	■		



**VCMT  
EN-MF**

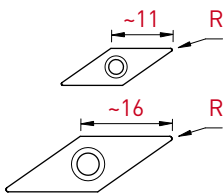

R	Old ref.	Art. N°	PVD			CVD
			Tmax	TAC	HTAC	Ti4
0.2	ISO-1622	VCMT-110302-EN-MF	■			■
0.4	ISO-1624	VCMT-110304-EN-MF	■			■
0.4	ISO-1724	VCMT-160404-EN-MF	■			■



**VCMT  
EN-HF**

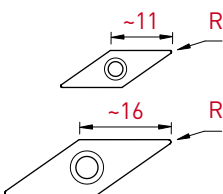





R	Old ref.	Art. N°	PVD			CVD
			Tmax	TAC	HTAC	Ti4
0.4	ISO-1694	VCMT-110304-EN-HF	■			■
0.8	ISO-1698	VCMT-110308-EN-HF	■			■
0.4	ISO-1794	VCMT-160404-EN-HF	■			■
0.8	ISO-1798	VCMT-160408-EN-HF	■			■

# ISO-Line

Accessoires

Zubehöre

Accessories

	Porte-outils Halter Holders	Vis Schrauben Screw	Clé Schlüssel Key	Option Art. N°	Recommandation de serrage Drehmoment Empfehlung Clamping recommendation
<b>Vis et clés de rechange</b> <b>Ersatzschrauben und Schlüssel</b> <b>Spare screws and keys</b>	Series SC...-06 Series SD...-07 Series SV...-11	<b>V-M2.5X7.8-T8</b> 	<b>C-T8</b> 	<b>SET-NM-TX8</b>	1.3 Nm
	Series SC...-09 Series SD...-11 Series SV...-16	<b>V-M4X9-T15-ISO</b> 	<b>C-T15</b> 	<b>SET-NM-TX15</b>	3 Nm



**SET-NM-TX8**  
**SET-NM-TX15**

APPLITEC SWISS TOOLING

OUTILS DE HAUTES PERFORMANCES  
POUR LE DÉCOLLETAGE  
ET LA MICROMÉCANIQUE

HOCHLEISTUNGSWERKZEUGE  
FÜR DREHAUTOMATEN  
UND MIKROMECHANIK

HIGH PERFORMANCE TOOLING  
FOR AUTOMATIC LATHES  
AND MICROMECHANICS



[WWW.APPLITEC-TOOLS.COM](http://WWW.APPLITEC-TOOLS.COM)

# CUT-Line

APPLITEC

Porte-outils / Halter / Holders

**H**

Système de serrage à bride - version courte  
Spannbrücke Klemmsystem - kurze Ausführung  
Independent top clamp system - short version

**HX**

Système de serrage à bride - version longue  
Spannbrücke Klemmsystem - lange Ausführung  
Independent top clamp system - long version

**HZ**

Porte-outils de grande capacité  
Klemmhalter für grössere Durchmesser  
High capacity tool holders

*Very rigid clamping system!*

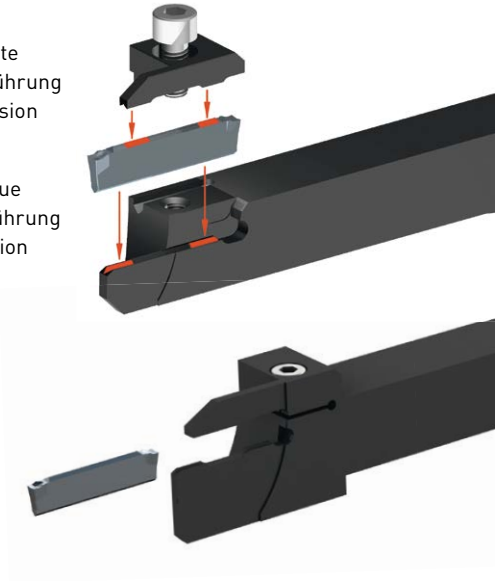

Plaquettes / WSP / Inserts

**CUT 16**

=

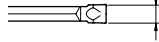

1.6 mm

Ø max 20 mm

**CUT 22**

=

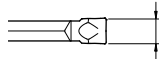

2.2 mm

Ø max 42 mm

**CUT 31**

=

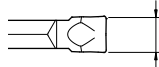

3.1 mm

Ø max 65 mm



**U**



**P**

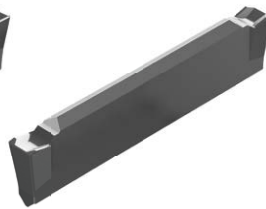

**T**



**G**

Nuances et géométries  
Sorten und Geometrien  
Grades and types of geometries **> 5.02**

**CUT 16** Ø max 20 mm **> 5.04**

Paramètres de coupe indicatifs  
Empfohlene Schnittwerte  
Standard machining data **CUT 22** Ø max 42 mm **> 5.06**

**CUT 31** Ø max 65 mm **> 5.08**

**H Series** **> 5.10**

Porte-outils  
Halter  
Holders **HX Series** **> 5.11**



**HZ Series** **> 5.12**

Porte-outils avec arrosage intégré  
Halter mit integriertem Kühlmittelzufuhr  
Holder with integrated coolant supply **NEW HZ-JET Series** **> 5.13**

**U Series** **> 5.14**

Plaquettes de tronçonnage  
Abstechwendeplatten  
Parting off inserts **NEW P Series** **> 5.16**

**T Series** **> 5.18**

Plaquettes de fonçage, tournage et tronçonnage  
WSP zum Einstecken, Drehen und Abstechen  
Inserts for grooving, turning and parting off **G Series** **> 5.19**

## TiALN

revêtement PVD  
PVD Beschichtung  
PVD coating

- pour l'usinage des aciers, aciers inoxydables et alliages de titane
- 1<sup>er</sup> choix pour les avances faibles à modérées

- für die Bearbeitung von Stahl, rostfreiem Stahl und Titanlegierungen
- beste Wahl für niedrige bis mittlere Vorschübe

- for machining of steel, stainless steel and titanium alloys
- first choice for low to average cutting speed

## Tmax

revêtement PVD  
PVD Beschichtung  
PVD coating

- nuance pour usinage moyen à lourd des aciers, aciers alliés et inoxydables
- bonne résistance aux températures d'usinage élevées
- 1<sup>er</sup> choix pour le tronçonnage des aciers au carbone et des aciers fortement alliés

- Sorte für mittlere bis hohe Belastung in Stahl und legierter Stahlbearbeitung
- gute Bearbeitungswarmfestigkeit
- bestens geeignet für die Bearbeitung von legiertem Kohlenstahl und hoch legiertem Stahl

- grade for medium to heavy machining of steel, stainless steel and alloyed steel
- high machining heat resistance
- first choice for the machining of carbon steel and high alloyed steel



## Zmax

revêtement PVD  
PVD Beschichtung  
PVD coating

- pour l'usinage des aciers, aciers inoxydables et alliages de titane en conditions défavorables
- bonne résistance aux chocs à des vitesses de coupe moyenne à faible
- 1<sup>er</sup> choix pour le tronçonnage en coupe interrompue

- für die Bearbeitung von Stahl, rostfreiem Stahl und Titanlegierungen in schwierige Bearbeitungsfälle
- gute Bruchfestigkeit mit durchschnittliche bis niedrige Schnittgeschwindigkeit
- für die Bearbeitung in unterbrochenen Schnitte bestens geeignet

- for machining of steel, stainless steel and titanium alloys in unfavourable machining conditions
- good impact resistance with average to low cutting speed
- first choice for machining in interrupted cut

## HTA

revêtement PVD  
PVD Beschichtung  
PVD coating

- très bonne résistance à l'usure
- pour le tronçonnage des aciers, aciers inoxydables et alliages de titane
- déconseillé en coupe interrompue

- sehr gute Verschleissfestigkeit
- für die Bearbeitung von Stahl, rostfreiem Stahl und Titanlegierung bestens geeignet
- für unterbrochene Schnitte ungeeignet

- very good wear resistance
- first choice for steel, stainless steel and titanium alloys machining
- not suitable for interrupted cut

## AS

revêtement PVD  
PVD Beschichtung  
PVD coating

- nuance pour métaux non ferreux
- très faible coefficient de frottement
- 1<sup>er</sup> choix pour l'usinage des aluminiums jusqu'à 5% Si, des cuivres et titanes faiblement alliés

- Sorte für Nichteisenmetalle
- sehr geringer Reibwert
- für die Bearbeitung von Aluminium bis 5% Si, Kupfer und niedriglegiertem Titan bestens geeignet

- grade for non-ferrous materials
- very low friction ratio
- first choice for Aluminium up to 5% Si, copper and low alloyed titanium



## Géométries de coupe

## Spanformgeometrie

## Cutting geometries

UN



- Géométrie positive universelle, bonne maîtrise du copeau
- Allgemeine Geometrie, sehr gute Spankontrolle
- All-round insert with efficient chip control

UR  
UL

PN



- Géométrie légèrement positive pour les aciers, aciers au carbone, aciers alliés
- Leicht positive Geometrie für Stahl, Kohlenstoffstahl, legiertem Stahl
- Slightly positive geometry for steel, carbon steel, alloyed steel

PR

TN



- Géométrie négative pour de fortes avances dans des conditions de rigidité favorable
- Negative Geometrie für hohe Vorschübe in guten Stabilitätsfällen
- Negative geometry for high feed rate in case of good stability

GN



- Géométrie universelle pour fonder-tourner, peut également être utilisée en tronçonnage
- Allgemeine Geometrie zum Einstecken-Langdrehen, kann auch zum Abstechen verwendet werden
- All-round insert for grooving and turning, can also be used for parting off

# CUT-Line

Paramètres de coupe indicatifs

Empfohlene Schnittwerte

Standard machining data

## CUT 16

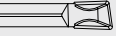
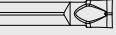
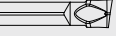
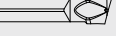
		P Acier Stahl Steel						M Inox Rostfreistahl Stainless steel		
		Acier de décolletage Automatenstahl Free-cutting steel		Acier faiblement allié Leicht legierter Stahl Low alloyed steel		Acier fortement allié Legierter Stahl High alloyed steel		Austénitique et martensitique Austenitisch und martensitisch Austenitic and martensitic		
		VC (m/min)	F (mm/U)	VC (m/min)	F (mm/U)	VC (m/min)	F (mm/U)	VC (m/min)	F (mm/U)	
Avance standard Standard Vorschub Standard feed rate	CUT16-UN-001 	TiALN	90-140	0.03-0.07	60-120	0.03-0.07	50-100	0.04-0.08	50-120	0.03-0.07
		Tmax	100-170	0.03-0.07	70-150	0.03-0.07	60-120	0.04-0.08	60-150	0.03-0.07
		HTA	70-120	0.03-0.05	60-100	0.03-0.05	50-90	0.03-0.05	50-100	0.03-0.06
	AS									
	CUT16-PR-801 	TiALN	90-140	0.03-0.07	60-120	0.03-0.07	50-100	0.03-0.07	50-120	0.03-0.07
		Tmax	100-170	0.03-0.07	70-150	0.03-0.07	60-120	0.03-0.07	60-150	0.03-0.07
Avance modérée Niedriger Vorschub Low feed rate	CUT16-UN-000 	TiALN	80-130	0.02-0.05	50-110	0.02-0.05	50-90	0.02-0.05	50-80	0.02-0.05
		HTA	60-100	0.01-0.04	50-90	0.01-0.04	50-80	0.02-0.05	50-80	0.02-0.05
		AS								
	CUT16-UL/R-800 	TiALN	80-130	0.02-0.05	50-110	0.02-0.05	50-90	0.02-0.05	50-80	0.02-0.05
		HTA	60-100	0.01-0.04	50-90	0.01-0.04	50-80	0.02-0.05	50-80	0.02-0.05
		AS								
	CUT16-UL/R-1500 	TiALN	80-130	0.02-0.05	50-110	0.02-0.05	50-90	0.02-0.05	50-80	0.02-0.05
		HTA	60-100	0.01-0.04	50-90	0.01-0.04	50-80	0.02-0.05	50-80	0.02-0.05
		AS								

\*\* arête de coupe vive

\*\* scharfe Schneidkante

\*\* sharp cutting edge

<b>N</b> Alliages d'aluminium et non ferreux Aluminium- und Nichteisenlegierungen Aluminium and non-ferrous alloys								<b>S</b> Titane Titan Titanium			
Aluminium		Alu silicium max. 5% Aluminiumsilicium max. 5% Aluminium silicon max. 5%		Cuivre Kupfer Copper		Laiton & bronze Messing & Bronze Brass & bronze		Gr. 1 - 3		Gr. 4 - 5	
VC (m/min)	F (mm/U)	VC (m/min)	F (mm/U)	VC (m/min)	F (mm/U)	VC (m/min)	F (mm/U)	VC (m/min)	F (mm/U)	VC (m/min)	F (mm/U)
100-250	0.03-0.10	100-250	0.03-0.10	100-300	0.03-0.10	100-300	0.03-0.10			30-60	0.04-0.08
100-300	0.04-0.10	100-250	0.04-0.10	100-300	0.03-0.08	150-300	0.03-0.08			30-60	0.04-0.08
150-300	0.04-0.15	100-300	0.04-0.10	100-300	0.04-0.10	150-300	0.02-0.08	30-60	0.04-0.08	30-60	0.04-0.08
						150-300	0.03-0.10				
100-300	0.02-0.05	100-250	0.01-0.04	100-250	0.01-0.04	100-300	0.02-0.05			30-60	0.01-0.04
100-300	0.02-0.05	100-250	0.02-0.05	100-250	0.02-0.05	100-300	0.02-0.05			30-60	0.02-0.06
100-300	0.02-0.05	100-250	0.02-0.05	100-250	0.02-0.05	100-300	0.02-0.05	30-60	0.02-0.06	30-60	0.02-0.06
100-300	0.02-0.05	100-250	0.01-0.04	100-250	0.01-0.04	100-300	0.02-0.05			30-60	0.01-0.04
100-300	0.02-0.05	100-250	0.02-0.05	100-250	0.02-0.05	100-300	0.02-0.05			30-60	0.02-0.06
100-300	0.02-0.05	100-250	0.02-0.05	100-250	0.02-0.05	100-300	0.02-0.05	30-60	0.02-0.06	30-60	0.02-0.06
100-300	0.02-0.05	100-250	0.01-0.04	100-250	0.01-0.04	100-300	0.02-0.05			30-60	0.01-0.04
100-300	0.02-0.05	100-250	0.02-0.05	100-250	0.02-0.05	100-300	0.02-0.05			30-60	0.02-0.06
100-300	0.02-0.05	100-250	0.02-0.05	100-250	0.02-0.05	100-300	0.02-0.05	30-60	0.02-0.06	30-60	0.02-0.06

★★★★★

★★★★

★★★







# CUT-Line

Paramètres de coupe indicatifs

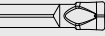
Empfohlene Schnittwerte

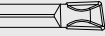
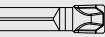
Standard machining data

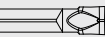
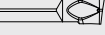
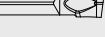
## CUT 22

		P Acier Stahl Steel						M Inox Rostfreistahl Stainless steel		
		Acier de décolletage Automatenstahl Free-cutting steel		Acier faiblement allié Leicht legierter Stahl Low alloyed steel		Acier fortement allié Legierter Stahl High alloyed steel		Austenitique et martensitique Austenitic and martensitic		
		VC (m/min)	F (mm/U)	VC (m/min)	F (mm/U)	VC (m/min)	F (mm/U)	VC (m/min)	F (mm/U)	
Avance standard Standard Vorschub Standard feed rate	 CUT22-UN-002	TiALN	90-140	0.04-0.08	60-120	0.04-0.08	50-100	0.04-0.08	50-120	0.04-0.08
		Tmax	100-170	0.04-0.08	70-150	0.04-0.08	60-120	0.04-0.08	60-150	0.04-0.08
		Zmax	80-130*	0.04-0.10	50-110*	0.04-0.10	50-90*	0.04-0.08	50-120*	0.04-0.10
		HTA	70-120	0.04-0.06	60-100	0.04-0.06	50-90	0.04-0.06	50-100	0.04-0.06
		AS								
	 CUT22-PN-002	TiALN	90-140	0.04-0.10	60-120	0.04-0.08	50-100	0.04-0.08		
		Tmax	100-170	0.04-0.10	70-150	0.04-0.10	60-120	0.04-0.10		
	 CUT22-PR-002	TiALN	90-140	0.04-0.08	60-120	0.04-0.08	50-100	0.04-0.08	50-120	0.04-0.08
		Tmax	100-170	0.04-0.08	70-150	0.04-0.08	60-120	0.04-0.08	60-150	0.04-0.08
	 CUT22-TN-002	TiALN	90-140	0.08-0.18	60-120	0.08-0.18	50-100	0.08-0.15	50-120	0.08-0.20
		Tmax	100-170	0.08-0.18	70-150	0.08-0.18	60-120	0.08-0.15	60-150	0.08-0.20
		Zmax	80-130*	0.08-0.18	50-110*	0.08-0.18	50-90*	0.08-0.15		
	 CUT22-GN-002 ***	TiALN	90-140	0.03-0.12	60-120	0.03-0.12	50-100	0.03-0.10	50-120	0.03-0.08
		Tmax	100-170	0.03-0.12	70-150	0.03-0.12	60-120	0.03-0.10	70-120	0.03-0.08
		AS								
Avance modérée Niedriger Vorschub Low feed rate	 CUT22-UN-000	TiALN	80-130	0.02-0.05	50-110	0.02-0.05	50-90	0.02-0.05	50-80	0.02-0.05
		HTA	60-100	0.01-0.04	50-90	0.01-0.04	50-80	0.02-0.05	50-80	0.02-0.05
		AS								
	 CUT22-UL/R-800	TiALN	80-130	0.02-0.05	50-110	0.02-0.05	50-90	0.02-0.05	50-80	0.02-0.05
		HTA	60-100	0.01-0.04	50-90	0.01-0.04	50-80	0.02-0.05	50-80	0.02-0.05
		AS								
	 CUT22-UL/R-802	TiALN	80-130	0.02-0.05	50-110	0.02-0.05	50-90	0.02-0.05	50-80	0.02-0.05
		HTA	60-100	0.01-0.04	50-90	0.01-0.04	50-80	0.02-0.05	50-80	0.02-0.05
		AS								
	 CUT22-UL/R-1500	TiALN	80-130	0.02-0.05	50-110	0.02-0.05	50-90	0.02-0.05	50-80	0.02-0.05
		HTA	60-100	0.01-0.04	50-90	0.01-0.04	50-80	0.02-0.05	50-80	0.02-0.05
		AS								

\* premier choix en cas de coupe interrompue

\*\* arête de coupe vive

\*\*\* géométrie fonçage-tournage (évent. tronçonnage)

\* beste Basis für unterbrochene Schnitte

\*\* scharfe Schneidkante

\*\*\* Geometrie zum einstechen und drehen (event. abstechen)

\* first choice for interrupted cut

\*\* sharp cutting edge

\*\*\* geometry for grooving and turning (event. parting off)

<span style="border: 1px solid black; padding: 2px;">N</span> Alliajes d'aluminium et non ferreux Aluminium- und Nichteisenlegierungen Aluminium and non-ferrous alloys								<span style="border: 1px solid black; padding: 2px;">S</span> Titane Titan Titanium			
Aluminium		Alu silicium max. 5% Aluminiumsilicium max. 5% Aluminium silicon max. 5%		Cuivre Kupfer Copper		Laiton & bronze Messing & Bronze Brass & bronze		Gr. 1 - 3		Gr. 4 - 5	
VC (m/min)	F (mm/U)	VC (m/min)	F (mm/U)	VC (m/min)	F (mm/U)	VC (m/min)	F (mm/U)	VC (m/min)	F (mm/U)	VC (m/min)	F (mm/U)
100-250	0.03-0.10	100-250	0.03-0.10	100-300	0.03-0.10	100-300	0.03-0.10			30-60	0.04-0.08
100-300	0.04-0.10	100-250	0.04-0.10	100-300	0.03-0.08	150-300	0.03-0.08			30-60	0.04-0.08
150-300	0.04-0.15	100-300	0.04-0.10	100-300	0.04-0.10	150-300	0.02-0.08	30-60	0.04-0.08	30-60	0.04-0.08
						150-300	0.03-0.10				
						150-300	0.03-0.10				
						150-300	0.05-0.2				
100-300	0.03-0.12	100-200	0.03-0.10	100-200	0.03-0.10	100-300	0.03-0.12			30-60	0.04-0.08
						100-300	0.03-0.12				
100-300	0.03-0.12	100-200	0.03-0.10	100-200	0.03-0.10	100-300	0.03-0.12	30-60	0.04-0.08	30-60	0.04-0.08
100-300	0.02-0.05	100-250	0.01-0.04	100-250	0.01-0.04	100-300	0.02-0.05			30-60	0.01-0.04
100-300	0.02-0.05	100-250	0.02-0.05	100-250	0.02-0.05	100-300	0.02-0.05			30-60	0.02-0.06
100-300	0.02-0.05	100-250	0.02-0.05	100-250	0.02-0.05	100-300	0.02-0.05	30-60	0.02-0.06	30-60	0.02-0.06
100-300	0.02-0.05	100-250	0.01-0.04	100-250	0.01-0.04	100-300	0.02-0.05			30-60	0.01-0.04
100-300	0.02-0.05	100-250	0.02-0.05	100-250	0.02-0.05	100-300	0.02-0.05			30-60	0.02-0.06
100-300	0.02-0.05	100-250	0.02-0.05	100-250	0.02-0.05	100-300	0.02-0.05	30-60	0.02-0.06	30-60	0.02-0.06
100-300	0.02-0.05	100-250	0.01-0.04	100-250	0.01-0.04	100-300	0.02-0.05			30-60	0.01-0.04
100-300	0.02-0.05	100-250	0.02-0.05	100-250	0.02-0.05	100-300	0.02-0.05			30-60	0.02-0.06
100-300	0.02-0.05	100-250	0.02-0.05	100-250	0.02-0.05	100-300	0.02-0.05	30-60	0.02-0.06	30-60	0.02-0.06
100-300	0.02-0.05	100-250	0.01-0.04	100-250	0.01-0.04	100-300	0.02-0.05			30-60	0.01-0.04
100-300	0.02-0.05	100-250	0.02-0.05	100-250	0.02-0.05	100-300	0.02-0.05			30-60	0.02-0.06
100-300	0.02-0.05	100-250	0.02-0.05	100-250	0.02-0.05	100-300	0.02-0.05	30-60	0.02-0.06	30-60	0.02-0.06

★★★★★

★★★★

★★★





# CUT-Line

Paramètres de coupe indicatifs

Empfohlene Schnittwerte

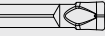
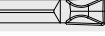
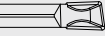
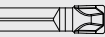
Standard machining data

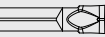
## CUT 31

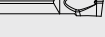
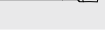
		P Acier Stahl Steel						M Inox Rostfreistahl Stainless steel		
		Acier de décolletage Automatenstahl Free-cutting steel		Acier faiblement allié Leicht legierter Stahl Low alloyed steel		Acier fortement allié Legierter Stahl High alloyed steel		Austenitique et martensitique Austenitic and martensitic		
		VC (m/min)	F (mm/U)	VC (m/min)	F (mm/U)	VC (m/min)	F (mm/U)	VC (m/min)	F (mm/U)	
Avance standard Standard Vorschub Standard feed rate	 CUT31-UN-002	TiALN	90-140	0.04-0.08	60-120	0.04-0.08	50-100	0.04-0.08	50-120	0.04-0.10
		Tmax	100-170	0.04-0.08	70-150	0.04-0.08	60-120	0.04-0.08	60-150	0.04-0.10
		Zmax	80-130*	0.04-0.10	50-110*	0.04-0.10	50-90*	0.04-0.08	50-120*	0.04-0.10
		HTA	70-120	0.04-0.06	60-100	0.04-0.06	50-90	0.04-0.06	50-100	0.04-0.06
		AS								
	 CUT31-PN-002	TiALN	90-140	0.04-0.10	60-120	0.04-0.08	50-100	0.04-0.08		
		Tmax	100-170	0.04-0.10	70-150	0.04-0.10	60-120	0.04-0.10		
	 CUT31-PR-002	TiALN	90-140	0.04-0.08	60-120	0.04-0.08	50-100	0.04-0.08	50-120	0.04-0.08
		Tmax	100-170	0.04-0.08	70-150	0.04-0.08	60-120	0.04-0.08	60-150	0.04-0.08
	 CUT31-TN-002	TiALN	90-140	0.08-0.20	60-120	0.08-0.20	50-100	0.08-0.15	50-120	0.08-0.20
		Tmax	100-170	0.08-0.20	70-150	0.08-0.20	60-120	0.08-0.15	60-150	0.08-0.20
		Zmax	80-130*	0.08-0.20	50-110*	0.08-0.20	50-90*	0.08-0.15		
	 CUT31-GN-002 ***	TiALN	90-140	0.04-0.15	60-120	0.04-0.15	50-100	0.04-0.10	50-120	0.04-0.10
		Tmax	100-170	0.04-0.15	70-150	0.04-0.15	60-120	0.04-0.10	70-120	0.04-0.10
		AS								
Avance modérée Niedriger Vorschub Low feed rate	 CUT31-UN-000	TiALN	80-130	0.02-0.05	50-110	0.02-0.05	50-90	0.02-0.05	50-80	0.02-0.05
		HTA	60-100	0.01-0.04	50-90	0.01-0.04	50-80	0.02-0.05	50-80	0.02-0.05
		AS								
	 CUT31-UL/R-800	TiALN	80-130	0.02-0.05	50-110	0.02-0.05	50-90	0.02-0.05	50-80	0.02-0.05
		HTA	60-100	0.01-0.04	50-90	0.01-0.04	50-80	0.02-0.05	50-80	0.02-0.05
		AS								
	 CUT31-UL/R-802	TiALN	80-130	0.02-0.05	50-110	0.02-0.05	50-90	0.02-0.05	50-80	0.02-0.05
		HTA	60-100	0.01-0.04	50-90	0.01-0.04	50-80	0.02-0.05	50-80	0.02-0.05
		AS								
	 CUT31-UL/R-1500	TiALN	80-130	0.02-0.05	50-110	0.02-0.05	50-90	0.02-0.05	50-80	0.02-0.05
		HTA	60-100	0.01-0.04	50-90	0.01-0.04	50-80	0.02-0.05	50-80	0.02-0.05
		AS								

\* premier choix en cas de coupe interrompue

\*\* arête de coupe vive

\*\*\* géométrie fonçage-tournage (évent. tronçonnage)

\* beste Basis für unterbrochene Schnitte

\*\* scharfe Schneidkante

\*\*\* Geometrie zum einstechen und drehen (event. abstechen)

\* first choice for interrupted cut

\*\* sharp cutting edge

\*\*\* geometry for grooving and turning (event. parting off)

[N] Alliages d'aluminium et non ferreux Aluminium- und Nichteisenlegierungen Aluminium and non-ferrous alloys								[S] Titane Titan Titanium			
Aluminium		Alu silicium max. 5% Aluminiumsilicium max. 5% Aluminium silicon max. 5%		Cuivre Kupfer Copper		Laiton & bronze Messing & Bronze Brass & bronze		Gr. 1 - 3		Gr. 4 - 5	
VC (m/min)	F (mm/U)	VC (m/min)	F (mm/U)	VC (m/min)	F (mm/U)	VC (m/min)	F (mm/U)	VC (m/min)	F (mm/U)	VC (m/min)	F (mm/U)
100-250	0.03-0.10	100-250	0.03-0.10	100-300	0.03-0.10	100-300	0.03-0.10			30-60	0.04-0.08
100-300	0.04-0.10	100-250	0.04-0.10	100-300	0.03-0.08	150-300	0.03-0.08			30-60	0.04-0.08
150-300	0.04-0.15	100-300	0.04-0.10	100-300	0.04-0.10	150-300	0.02-0.08	30-60	0.04-0.08	30-60	0.04-0.08
						150-300	0.03-0.10				
						150-300	0.03-0.10				
						150-300	0.05-0.20				
100-300	0.04-0.15	100-200	0.04-0.10	100-200	0.04-0.10	100-300	0.04-0.15			30-60	0.04-0.08
						100-300	0.04-0.15				
100-300	0.04-0.15	100-200	0.04-0.10	100-200	0.04-0.10	100-300	0.04-0.15	30-60	0.04-0.08	30-60	0.04-0.08
100-300	0.02-0.05	100-250	0.01-0.04	100-250	0.01-0.04	100-300	0.02-0.05			30-60	0.01-0.04
100-300	0.02-0.05	100-250	0.02-0.05	100-250	0.02-0.05	100-300	0.02-0.05			30-60	0.02-0.06
100-300	0.02-0.05	100-250	0.02-0.05	100-250	0.02-0.05	100-300	0.02-0.05	30-60	0.02-0.06	30-60	0.02-0.06
100-300	0.02-0.05	100-250	0.01-0.04	100-250	0.01-0.04	100-300	0.02-0.05			30-60	0.01-0.04
100-300	0.02-0.05	100-250	0.02-0.05	100-250	0.02-0.05	100-300	0.02-0.05			30-60	0.02-0.06
100-300	0.02-0.05	100-250	0.02-0.05	100-250	0.02-0.05	100-300	0.02-0.05	30-60	0.02-0.06	30-60	0.02-0.06
100-300	0.02-0.05	100-250	0.01-0.04	100-250	0.01-0.04	100-300	0.02-0.05			30-60	0.01-0.04
100-300	0.02-0.05	100-250	0.02-0.05	100-250	0.02-0.05	100-300	0.02-0.05			30-60	0.02-0.06
100-300	0.02-0.05	100-250	0.02-0.05	100-250	0.02-0.05	100-300	0.02-0.05	30-60	0.02-0.06	30-60	0.02-0.06
100-300	0.02-0.05	100-250	0.01-0.04	100-250	0.01-0.04	100-300	0.02-0.05			30-60	0.01-0.04
100-300	0.02-0.05	100-250	0.02-0.05	100-250	0.02-0.05	100-300	0.02-0.05			30-60	0.02-0.06
100-300	0.02-0.05	100-250	0.02-0.05	100-250	0.02-0.05	100-300	0.02-0.05	30-60	0.02-0.06	30-60	0.02-0.06

★★★★★

★★★★

★★★

# CUT-Line

Porte-outils

Halter

Holder

∅ max 34 mm

H Series

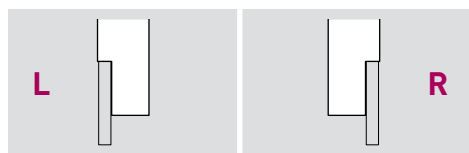
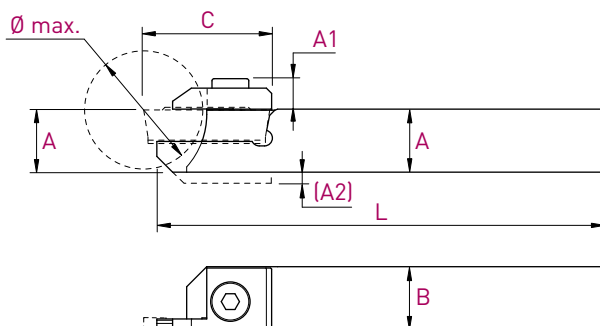

Plaquette WSP Insert	A x B x L	∅ max.	A1	C	Art. N°	Art. N°
<b>W</b> 1.6 mm <b>Type</b> CUT16	8 x 10 x 115 (A2=2)	16	6.2	19.5	CUT16-H0810L	CUT16-H0810R
	10 x 10 x 115	16	6.2	19.5	CUT16-H1010L	CUT16-H1010R
	12 x 12 x 130	16	6.2	19.5	CUT16-H1212L	CUT16-H1212R
	12 x 12 x 90	16	6.2	19.5	CUT16-H1212L-90	CUT16-H1212R-90
	12.7 x 12.7 x 130	16	6.2	19.5	CUT16-H127127L	CUT16-H127127R
	16 x 16 x 130	16	6.2	19.5	CUT16-H1616L	CUT16-H1616R
20 x 20 x 120	16	6.2	19.5	CUT16-H2020L	CUT16-H2020R	
<b>W</b> 2.2 mm <b>Type</b> CUT22	10 x 12 x 115	20	6.4	24	CUT22-H1012L	CUT22-H1012R
	12 x 12 x 130	20	6.4	24	CUT22-H1212L	CUT22-H1212R
	12 x 12 x 90	20	6.4	24	CUT22-H1212L-90	CUT22-H1212R-90
	12.7 x 12.7 x 130	20	6.4	24	CUT22-H127127L	CUT22-H127127R
	16 x 16 x 130	20	6.4	24	CUT22-H1616L	CUT22-H1616R
20 x 20 x 120	20	6.4	24	CUT22-H2020L	CUT22-H2020R	
<b>W</b> 3.1 mm <b>Type</b> CUT31	16 x 16 x 130	34	7.8	35	CUT31-H1616L	CUT31-H1616R
	20 x 20 x 120	34	7.8	35	CUT31-H2020L	CUT31-H2020R
	25 x 25 x 140	34	7.8	35	CUT31-H2525L	CUT31-H2525R

Pièces de rechange Ersatzteile Spare parts	L	R		Serrage Drehmoment Torque
	Art. N°	Art. N°	Art. N°	
CUT 16	CUT16L-SET	CUT16R-SET	V-M4X10-BN7	3.5 Nm
CUT 22	CUT22L-SET	CUT22R-SET	V-M4X10-BN7	3.5 Nm
CUT 31	CUT31L-SET	CUT31R-SET	V-M5X10-BN7	4.5 Nm



Porte-outils

Halter

Holder

Ø max 42 mm

HX Series

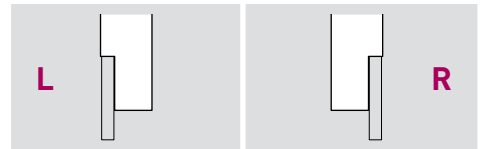
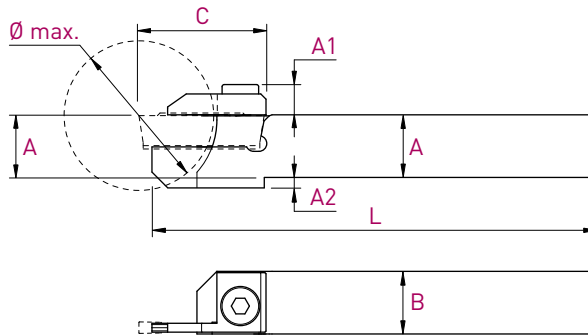

Plaquette WSP Insert	A x B x L	Ø max.	A1	C	A2	Art. N°	Art. N°
<b>W</b> 1.6 mm <b>Type</b> CUT16	10 x 12 x 115	20	6.2	21	2	CUT16-H1012LX	CUT16-H1012RX
	12 x 12 x 130	20	6.2	21	-	CUT16-H1212LX	CUT16-H1212RX
	12 x 12 x 90	20	6.2	21	-	CUT16-H1212LX-90	CUT16-H1212RX-90
	12.7 x 12.7 x 130	20	6.2	21	-	CUT16-H127127LX	CUT16-H127127RX
	16 x 16 x 130	20	6.2	21	-	CUT16-H1616LX	CUT16-H1616RX
	20 x 20 x 120	20	6.2	21	-	CUT16-H2020LX	CUT16-H2020RX
<b>W</b> 2.2 mm <b>Type</b> CUT22	10 x 12 x 115	26	6.4	25	4	CUT22-H1012LX	CUT22-H1012RX
	12 x 12 x 130	26	6.4	25	2	CUT22-H1212LX	CUT22-H1212RX
	12 x 12 x 90	26	6.4	25	2	CUT22-H1212LX-90	CUT22-H1212RX-90
	12.7 x 12.7 x 130	26	6.4	25	-	CUT22-H127127LX	CUT22-H127127RX
	16 x 16 x 130	26	6.4	25	-	CUT22-H1616LX	CUT22-H1616RX
	20 x 20 x 120	26	6.4	25	-	CUT22-H2020LX	CUT22-H2020RX
<b>W</b> 3.1 mm <b>Type</b> CUT31	16 x 16 x 120	42	7.8	37	4	CUT31-H1616LX	CUT31-H1616RX
	20 x 20 x 120	42	7.8	37	-	CUT31-H2020LX	CUT31-H2020RX
	25 x 25 x 140	42	7.8	37	-	CUT31-H2525LX	CUT31-H2525RX

Pièces de rechange Ersatzteile Spare parts	L	R		Serrage Drehmoment Torque
	Art. N°	Art. N°	Art. N°	
CUT 16	CUT16LX-SET	CUT16RX-SET	V-M4X10-BN7	3.5 Nm
CUT 22	CUT22LX-SET	CUT22RX-SET	V-M4X10-BN7	3.5 Nm
CUT 31	CUT31LX-SET	CUT31RX-SET	V-M5X10-BN7	4.5 Nm

# CUT-Line

Porte-outils

Halter

Holder

∅ max 65 mm

HZ Series

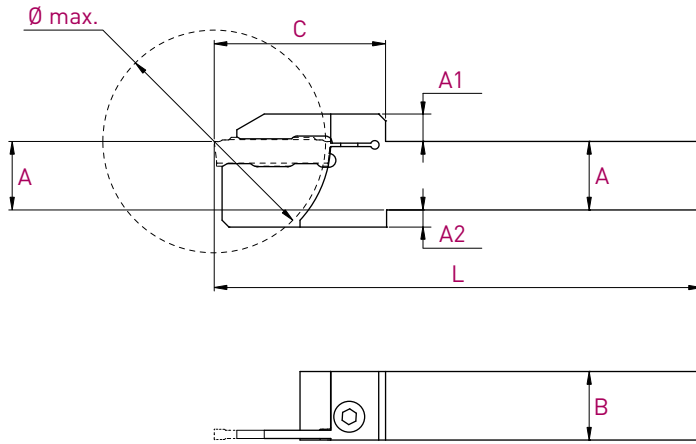

Plaquette WSP Insert	A x B x L	∅ max.	A1	C	A2	Art. N°	Art. N°
<b>W</b> 2.2 mm	16 x 16 x 130	32	7	30	-	<b>CUT22-H1616LZ-D32</b>	<b>CUT22-H1616RZ-D32</b>
	20 x 20 x 130	32	7	30	-	<b>CUT22-H2020LZ-D32</b>	<b>CUT22-H2020RZ-D32</b>
<b>Type</b> CUT22	16 x 16 x 130	42	7	35	4	<b>CUT22-H1616LZ-D42</b>	<b>CUT22-H1616RZ-D42</b>
	20 x 20 x 130	42	7	35	-	<b>CUT22-H2020LZ-D42</b>	<b>CUT22-H2020RZ-D42</b>
<b>W</b> 3.1 mm	20 x 20 x 140	52	8	44	5	<b>CUT31-H2020LZ-D52</b>	<b>CUT31-H2020RZ-D52</b>
	25 x 25 x 140	52	8	44	-	<b>CUT31-H2525LZ-D52</b>	<b>CUT31-H2525RZ-D52</b>
<b>Type</b> CUT31	20 x 20 x 140	65	8	50	5	<b>CUT31-H2020LZ-D65</b>	<b>CUT31-H2020RZ-D65</b>
	25 x 25 x 140	65	8	50	-	<b>CUT31-H2525LZ-D65</b>	<b>CUT31-H2525RZ-D65</b>

Pièces de rechange Ersatzteile Spare parts		Serrage Drehmoment Torque
	Art. N°	
CUT 22	<b>V-M4X10-BN7</b>	3.5 Nm
CUT 31	<b>V-M5X10-BN7</b>	4.5 Nm

Porte-outils avec arrosage intégré

Halter mit integriertem Kühlmittelzufuhr

Holder with integrated coolant supply

## HZ-JET Series

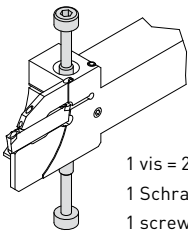
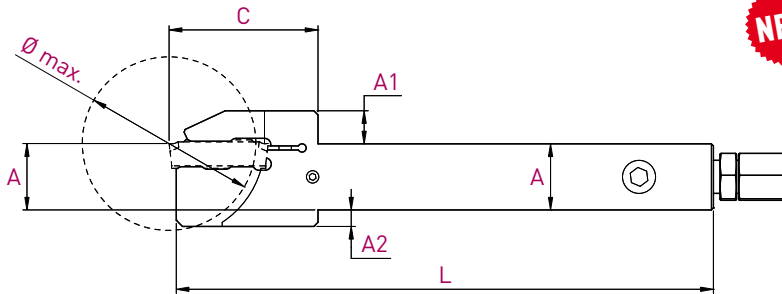

1 vis = 2 possibilités de serrage  
 1 Schraube = 2 Spannmöglichkeiten  
 1 screw = 2 clamp possibilities

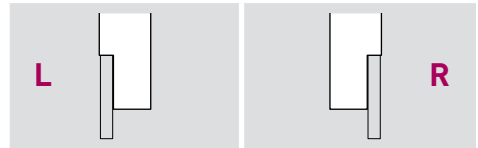

Plaquette WSP Insert	A x B x L	Ø max.	A1	C	A2	Art. N°	Art. N°
<b>Type</b> CUT22	16 x 16 x 130	42	8	36	4	CUT22-H1616LZ-JET42	CUT22-H1616RZ-JET42
	20 x 20 x 130	42	8	36	-	CUT22-H2020LZ-JET42	CUT22-H2020RZ-JET42
<b>Type</b> CUT31	20 x 20 x 140	65	9	51	5	CUT31-H2020LZ-JET65	CUT31-H2020RZ-JET65
	25 x 25 x 140	65	9	51	-	CUT31-H2525LZ-JET65	CUT31-H2525RZ-JET65

Pièces de rechange Ersatzteile Spare parts		Serrage Drehmoment Torque		
	Art. N°		Art. N°	Art. N°
CUT 22	V-M4X22-CUT	3.5 Nm	J-M8X1-D6	JB-M8X1
CUT 31	V-M5X25-CUT	4.5 Nm	J-M8X1-D6	JB-M8X1

# CUT-Line

Plaquettes de tronçonnage

Abstechwendeplatten

Parting off inserts

UN Series

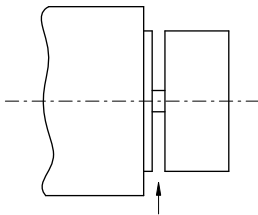
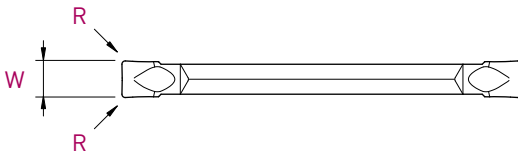
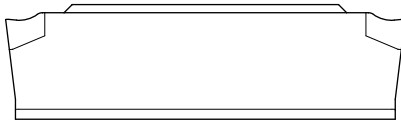

UN



Type	W $\pm 0.05$	R	Art. N°	TiALN	Tmax	Zmax	HTA	AS
CUT16	1.6	0.02	CUT16-UN-000	■			■	■
	1.6	0.10	CUT16-UN-001	■	■		■	■
CUT22	2.2	0.02	CUT22-UN-000	■			■	■
	2.2	0.20	CUT22-UN-002	■	■	■	■	■
CUT31	3.1	0.02	CUT31-UN-000	■			■	■
	3.1	0.20	CUT31-UN-002	■	■	■	■	■

Plaquettes de tronçonnage

Abstechwendeplatten

Parting off inserts

## UL-UR Series

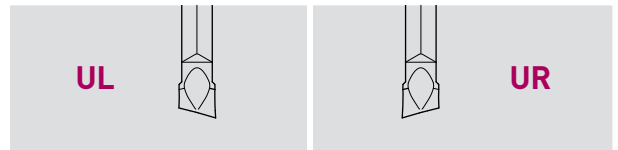
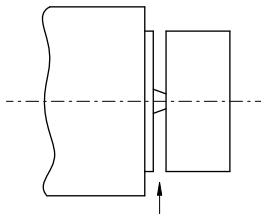
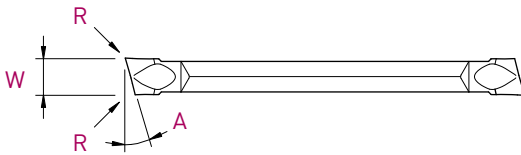
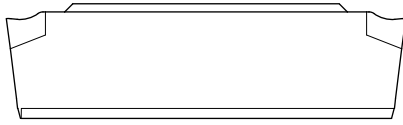

Type	W $\pm 0.05$	A	R	UL			UR				
				Art. N°	TiAlN	HTA	AS	Art. N°	TiAlN	HTA	AS
CUT16	1.6	8°	0.02	CUT16-UL-800	■	■	■	CUT16-UR-800	■	■	■
	1.6	15°	0.02	CUT16-UL-1500	■	■	■	CUT16-UR-1500	■	■	■
CUT22	2.2	8°	0.02	CUT22-UL-800	■	■	■	CUT22-UR-800	■	■	■
	2.2	8°	0.20	CUT22-UL-802	■	■	■	CUT22-UR-802	■	■	■
	2.2	15°	0.02	CUT22-UL-1500	■	■	■	CUT22-UR-1500	■	■	■
CUT31	3.1	8°	0.02	CUT31-UL-800	■	■	■	CUT31-UR-800	■	■	■
	3.1	8°	0.20	CUT31-UL-802	■	■	■	CUT31-UR-802	■	■	■
	3.1	15°	0.02	CUT31-UL-1500	■	■	■	CUT31-UR-1500	■	■	■

# CUT-Line

Plaquettes de tronçonnage

Abstechwendeplatten

Parting off inserts

PN Series

**NEW**

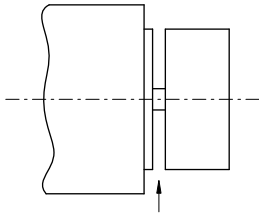
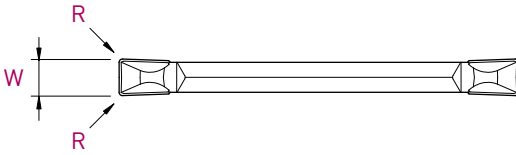
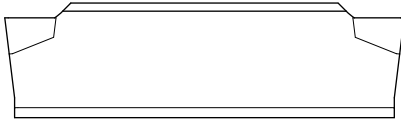

Type	W $\pm 0.05$	R	Art. N°	Ti/ALN	Tmax
CUT22	2.2	0.20	CUT22-PN-002	■	■
CUT31	3.1	0.20	CUT31-PN-002	■	■

Plaquettes de tronçonnage

Abstechwendeplatten

Parting off inserts

## PR Series

**NEW**

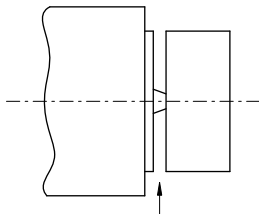
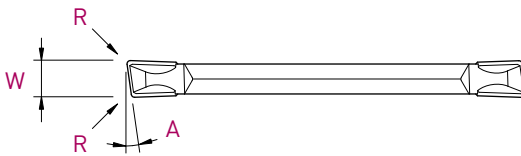
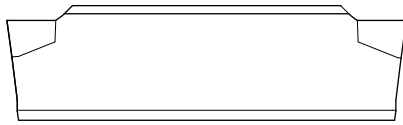

**PR**



Type	W $\pm 0.05$	A	R	Art. N°	TiALN	Tmax
CUT16	1.6	8°	0.10	CUT16-PR-801	■	■
CUT22	2.2	8°	0.20	CUT22-PR-802	■	■
CUT31	3.1	8°	0.20	CUT31-PR-802	■	■

# CUT-Line

Plaquettes de tronçonnage

Abstechwendeplatten

Parting off inserts

TN Series

Negative cut

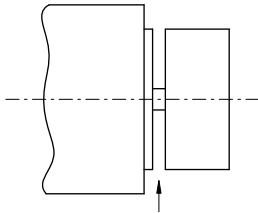
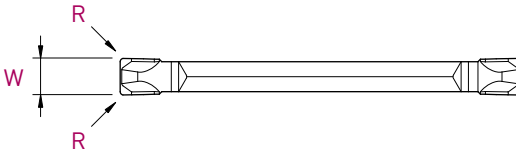
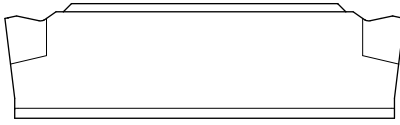

Type	W $\pm 0.05$	R	Art. N°	TiALN	Tmax	Zmax
CUT22	2.2	0.20	CUT22-TN-002	■	■	■
CUT31	3.1	0.20	CUT31-TN-002	■	■	■



Plaquettes de fonçage, tournage et tronçonnage

WSP zum Einstecken, Drehen und Abstechen

Inserts for grooving, turning and parting off

## GN Series

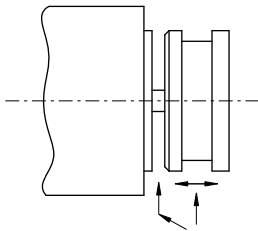
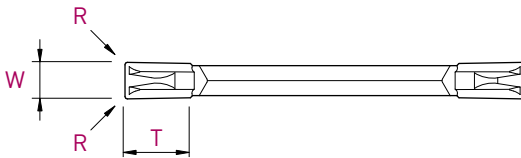
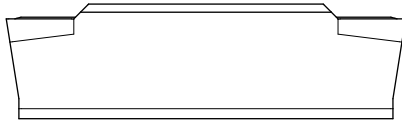

GN



Type	W ±0.05	T	R	Art. N°	TiAlN	Tmax	AS
CUT22	2.2	3.5	0.15	CUT22-GN-002	■	■	■
CUT31	3.1	5.0	0.15	CUT31-GN-002	■	■	■

Conseils d'utilisation pour plaquettes type GN

Anwendungsempfehlungen für GN-Wendelplatten

Application recommendations for GN inserts

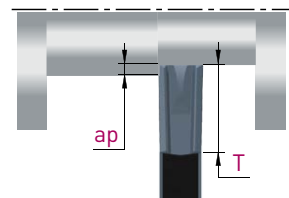
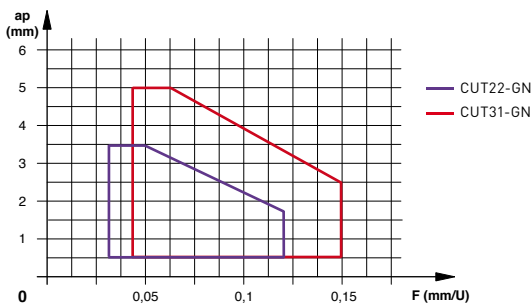

ap max = T dans matière à bonne usinabilité  
 ap max = T in Werkstoffe mit gute Zerspanbarkeit  
 ap max = T in material with good machinability

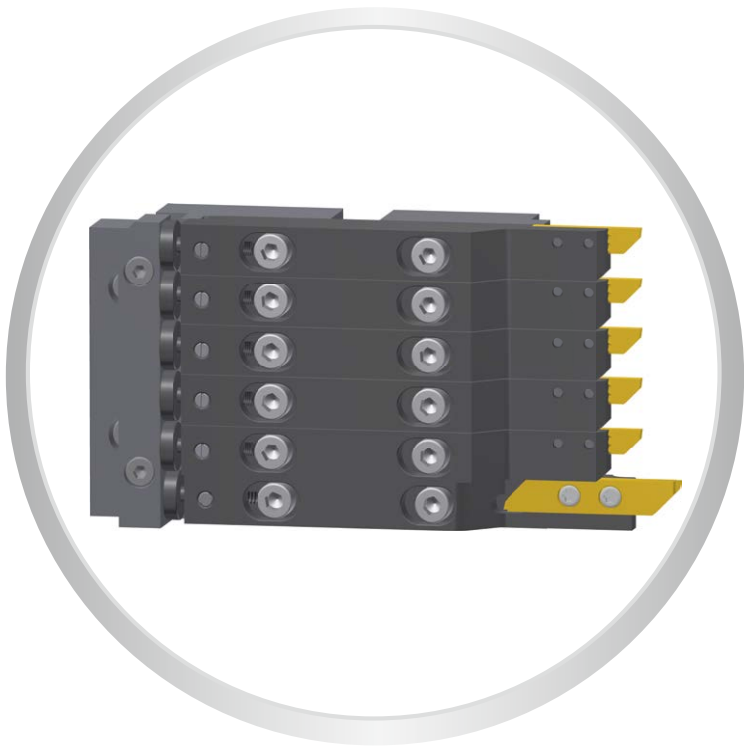

Système d'outils modulaires

Modulares Werkzeugsystem

Modular tooling system

Système d'outils modulaires  
pour tours automatiques

Modulares Werkzeugsystem  
für Langdrehautomaten

Modular tooling system for  
sliding automatic lathes

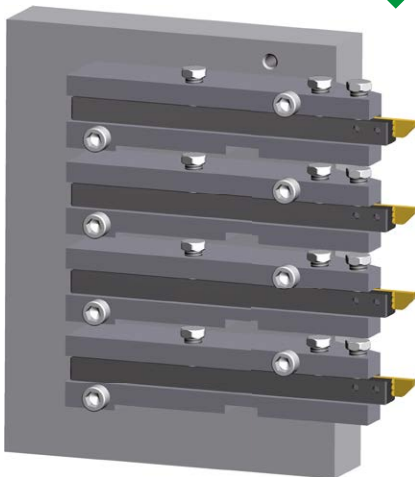
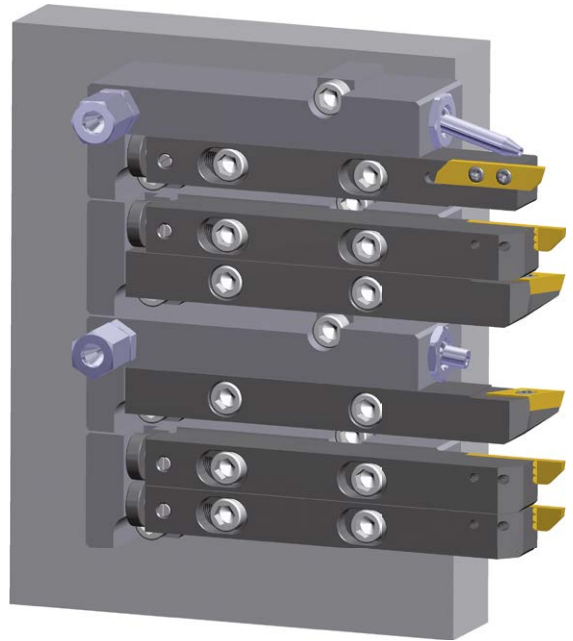

avec MODU-Line  
mit MODU-Line  
with MODU-Line

sans MODU-Line  
ohne MODU-Line  
without MODU-Line

# MODU-Line

Les avantages

Die Vorteile

The advantages

Plus d'outils disponibles  
Höhere Werkzeuganzahl  
More tools available



Système d'arrosage efficace  
Effizientes Kühlmittelzufuhrsystem  
Efficient coolant supply system

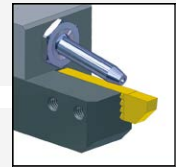
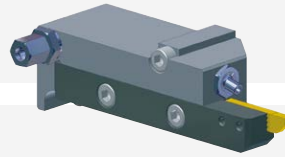

Système compatible avec d'autres fabricants  
Werkzeugsystem kompatibel mit anderen Lieferanten  
Standard system compatible with other suppliers

Possibilité de pré réglage et de réglage de la longueur des outils  
Voreinstellbar auf feste oder einstellbare Länge  
Presetting on fixed adjustable length



Système de fixation robuste et rigide  
Robustes und starres Spannsystem  
Strong and stable clamping system

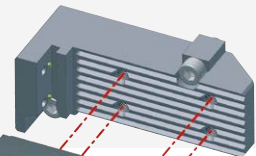

Changement d'outil simple et rapide  
Einfacher und schneller Werkzeugwechsel  
Easy and quick tool replacement

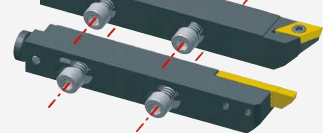

Adaptations disponibles pour les machines suivantes:  
 Verfügbare Anpassungen für folgende Maschinen:  
 Adapters available for the following machines:

**Citizen - Hanwha -  
 Manurhin - Star -  
 Tornos - Tsugami**

> **6.04**

Porte-outils  
 Halter  
 Holders

INFO > 6.27

**ML12**

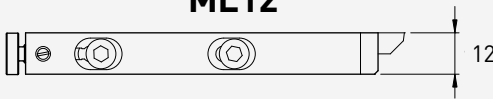

**ML16**

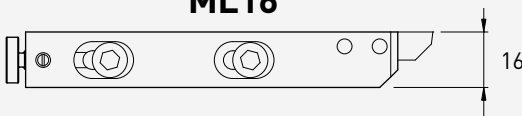

**ML20**

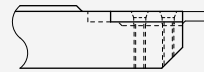
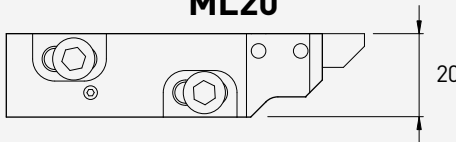

> **6.28**

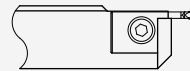

> **6.29**



> **6.30**

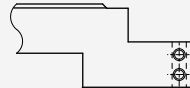

> **6.36**

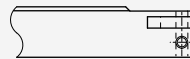

> **6.37**

Modules d'arrosage et de serrage  
 Kühlmitteldüse und Zufuhrelemente  
 Coolant and clamping supply unit



> **6.38**

Banc de pré réglage  
 Voreinstellgerät  
 Presetting device

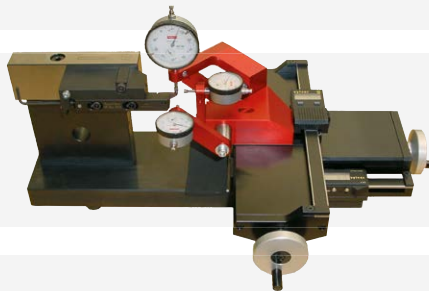

> **6.40**

Pièces de rechange  
 Ersatzteile  
 Spare parts



> **6.42**

Adaptations disponibles pour les machines suivantes

Verfügbare Anpassungen für folgende Maschinen

Adapters available for the following machines

Fabricant Hersteller Manufacturer	Machine Maschine Machine	Type Typ Type	Page Seite Page
Citizen	C12 / C16	ML12	6.05
	K12 / K16 type VII	ML16	6.06
	L16 / L20 type VII / VIII	ML16	6.07
Hanwha	SL 12/16	ML16	6.08
	XD 20M	ML12	6.09 <span style="color: red; font-weight: bold;">NEW</span>
Manurhin	KMX 426 / 526 / 626	ML16	6.10
	Swing 20-26	ML16	6.10
Star	SR-10J	ML12	6.11
	SA-12 / SA-16 / SA-16R	ML16	6.12
	SB-16	ML16	6.13
	SB-20C (E)	ML16	6.14
	SR 16 / SR-20R / SR-20RII	ML16	6.15
	SR-20-RIII	ML16	6.16
	SV 12/20	ML16	6.17
Tornos	Deco 7/10	ML12	6.18
	Deco 13	ML16	6.19
	Deco 20/26	ML16	6.20
	Sigma 20/32	ML16	6.21
	SwissNano	ML20	6.22 <span style="color: red; font-weight: bold;">NEW</span>
	Delta 12/20	ML12	6.25
Tsugami	Swiss ST26	ML16	6.26 <span style="color: red; font-weight: bold;">NEW</span>
	B012	ML20	6.25
	B020	ML20	6.25

Exemple d'implantation sur Tornos DECO 10

Einstellungsbeispiel auf Tornos DECO 10

Setting-up example on Tornos DECO 10

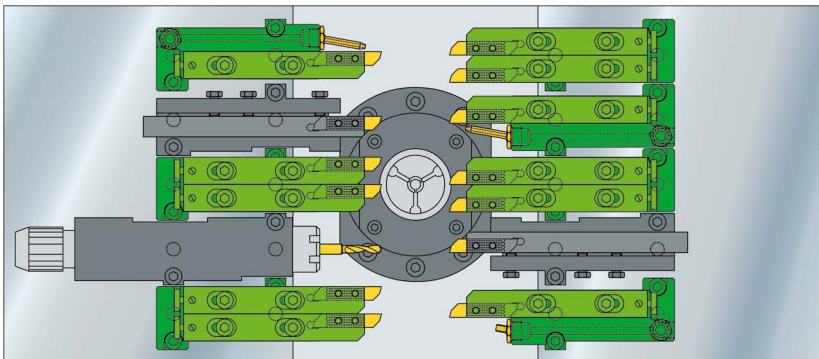

**Citizen C12 / C16**

+ 2 outils (max 8)  
 + 2 Werkzeuge (max 8)  
 + 2 tools (max 8)

**ML12**

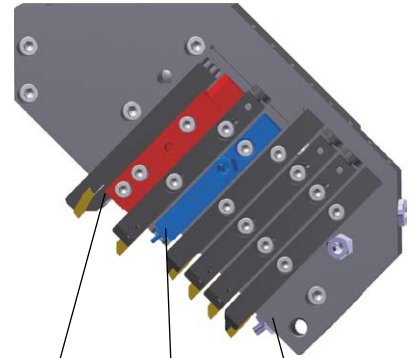
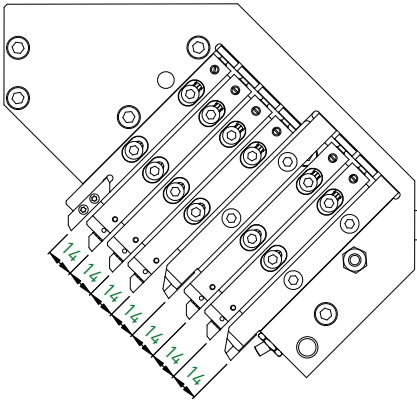

Outil  $\square$  12 mm possible avec module de serrage  
 Werkzeug  $\square$  12 mm mit Spannelement möglich  
 Tool  $\square$  12mm possible with clamping unit

Module d'arrosage (prend la place d'un outil)  
 Kühlmittelzufuhrelement (nimmt den Platz eines Werkzeuges)  
 Coolant supply unit (takes the place of one tool)

Arrosage intégré  
 Integrierter Kühlmittel  
 Integrated coolant

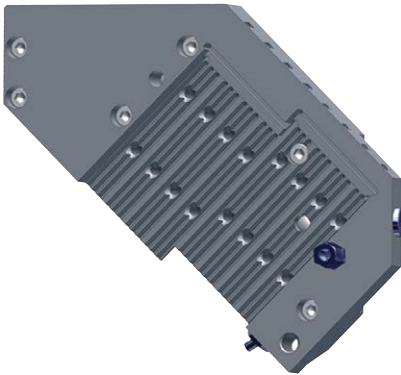

Support de base Grundhalter Base holder		Citizen C12 / C16		Accessoires Zubehöre Accessories	
Art. N°	Porte-outils Halter Holders	Pages Seiten Pages	Module de serrage Spannelement Clamping unit	Module d'arrosage Kühlmittelzufuhrelement Coolant supply unit	Page Seite Page
ML12-CITIZEN-C16	ML12	> 6.27	ML12-FIX-12/14	ML12-JET-5/16	6.38

# MODU-Line

Citizen K12 / K16

+ 2 outils (max 8)  
 + 2 Werkzeuge (max 8)  
 + 2 tools (max 8)

**ML16**

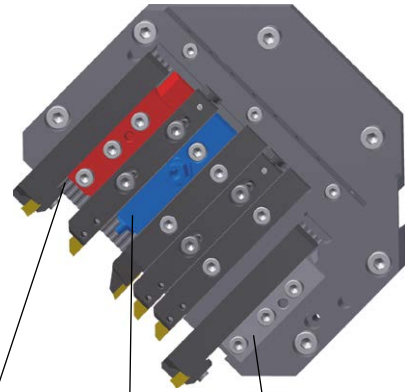
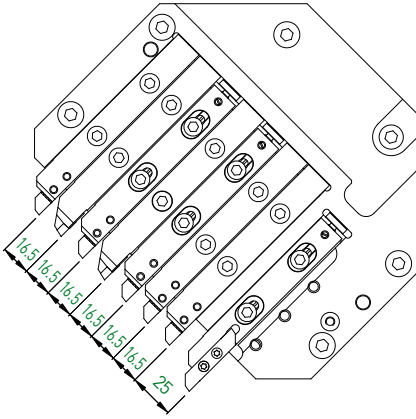

Outil  $\square$  16 mm possible avec module de serrage  
 Werkzeug  $\square$  16 mm mit Spannelement möglich  
 Tool  $\square$  16 mm possible with clamping unit

Module d'arrosage (prend la place d'un outil)  
 Kühlmittelzufuhrelement (nimmt den Platz eines Werkzeuges)  
 Coolant supply unit (takes the place of one tool)

1 serrage pour outil  $\square$  16 mm inclus  
 1 Spannung für Werkzeug  $\square$  16 mm inbegriffen  
 1 clamping for tool  $\square$  16 mm included

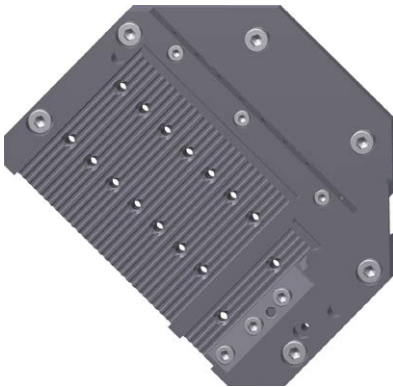

Support de base Grundhalter Base holder		Citizen K12 / K16		Accessoires Zubehöre Accessories	
Art. N°	Porte-outils Halter Holders	Pages Seiten Pages	Module de serrage Spannelement Clamping unit	Module d'arrosage Kühlmittelzufuhrelement Coolant supply unit	Page Seite Page
<b>ML16-CITIZEN-K16</b>	ML16	> 6.27	<b>ML16-FIX-16/16.5</b>	<b>ML16-JET-7/16</b>	6.38



Citizen L16 / L20

- + 1 outil (max 7)
- + 1 Werkzeug (max 7)
- + 1 tool (max 7)

**ML16**

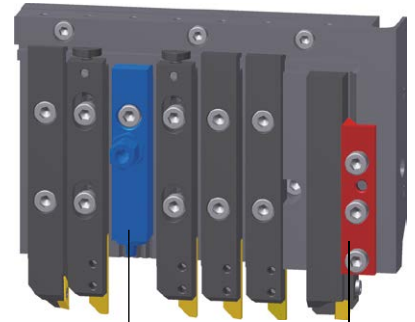
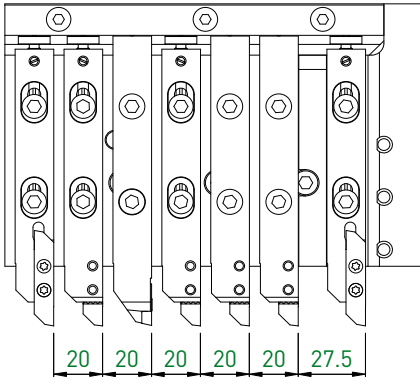

Module d'arrosage (prend la place d'un outil)  
 Kühlmittelzufuhrelement (nimmt den Platz eines Werkzeuges)  
 Coolant supply unit (takes the place of one tool)

1 serrage pour outil  $\varnothing$  16 mm inclus  
 1 Spannung für Werkzeug  $\varnothing$  16 mm inbegriffen  
 1 clamping for tool  $\varnothing$  16 mm included



Support de base Grundhalter Base holder		Citizen L16 / L20		Accessoires Zubehöre Accessories	
Art. N°	Porte-outils Halter Holders	Pages Seiten Pages	Module de serrage Spannelement Clamping unit	Module d'arrosage Kühlmittelzufuhrelement Coolant supply unit	Page Seite Page
ML16-CITIZEN-L20	ML16	> 6.27	<b>Inclus/inbegriffen/ included</b>	<b>ML16-JET-7/16</b>	6.38

# MODU-Line

Hanwha SL12 / 16

+ 1 outil (max 7)  
 + 1 Werkzeug (max 7)  
 + 1 tool (max 7)

**ML16**

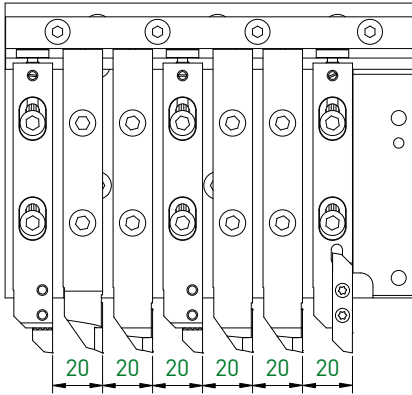

Module d'arrosage (prend la place d'un outil)  
 Kühlmittelzufuhrelement (nimmt den Platz eines Werkzeuges)  
 Coolant supply unit (takes the place of one tool)



Support de base Grundhalter Base holder		Hanwha SL12 / 16		Accessoires Zubehöre Accessories	
Art. N°	Porte-outils Halter Holders	Pages Seiten Pages	Module de serrage Spannelement Clamping unit	Module d'arrosage Kühlmittelzufuhrelement Coolant supply unit	Page Seite Page
ML16-HANWHA-SL12/16	ML16	> 6.27	-	<a href="#">ML16-JET-7/16</a>	6.38

**Hanwha XD20M**

+ 1 outil (max 7)  
 + 1 Werkzeug (max 7)  
 + 1 tool (max 7)

**ML12**

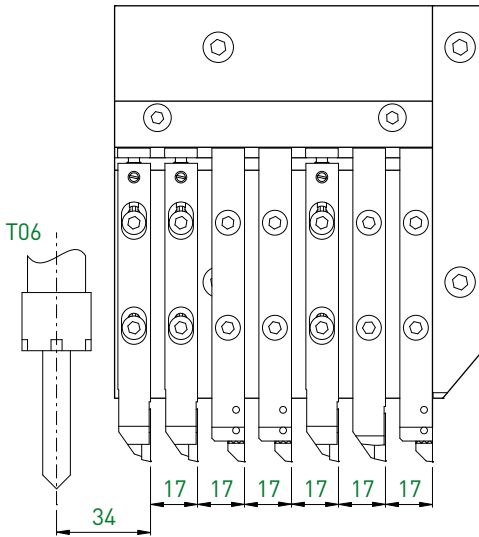

Module d'arrosage (prend la place d'un outil)  
 Kühlmittelzufuhrelement (nimmt den Platz eines Werkzeuges)  
 Coolant supply unit (takes the place of one tool)

**NEW**



Support de base Grundhalter Base holder		Hanwha XD20M		Accessoires Zubehöre Accessories	
Art. N°	Porte-outils Halter Holders	Pages Seiten Pages	Module de serrage Spannelement Clamping unit	Module d'arrosage Kühlmittelzufuhrelement Coolant supply unit	Page Seite Page
<b>ML12-HANWHA-XD20M</b>	ML12	> 6.27	-	<b>ML12-JET-5/16</b>	6.38

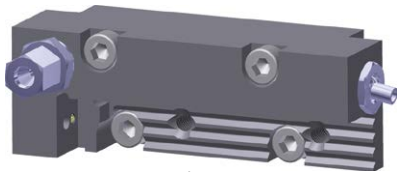
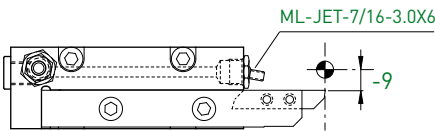
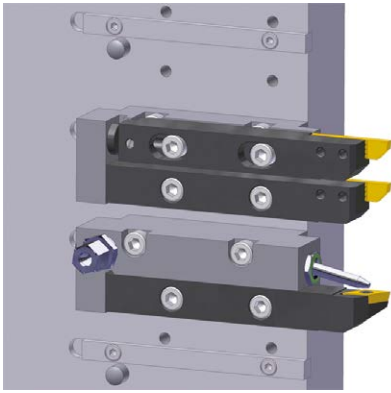

Jet

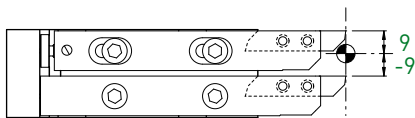

Duo

Support de base  
Grundhalter  
Base holder

Manurhin  
KMX 426/526/626 / Swing 20-26 mm

Type Typ Type	Art. N°	Porte-outils Halter Holders	Pages Seiten Pages
Jet	<b>ML16-KMX26-JET</b>	ML16	> 6.27
Duo	<b>ML16-KMX26-DUO</b>	ML16	> 6.27

Accessoires  
Zubehöre  
Accessories

Buses d'arrosage  
Kühlmitteldüse  
Coolant nozzles

Page  
Seite  
Page

**ML-JET-7/16...**

6.39

Star SR-10J

+ 2 outils (max 8)  
 + 2 Werkzeuge (max 8)  
 + 2 tools (max 8)

ML12

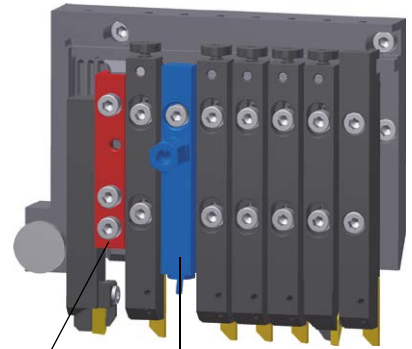
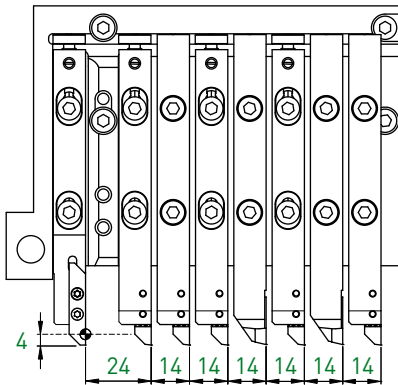

1 serrage pour outil  $\square$  12 mm inclus  
 1 Spannung für Werkzeug  $\square$  12 mm inbegriffen  
 1 clamping for tool  $\square$  12 mm included

Module d'arrosage (prend la place d'un outil)  
 Kühlmittelzufuhrelement (nimmt den Platz eines Werkzeuges)  
 Coolant supply unit (takes the place of one tool)



Support de base Grundhalter Base holder		Star SR-10J		Accessoires Zubehöre Accessories	
Art. N°	Porte-outils Halter Holders	Pages Seiten Pages	Module de serrage Spannelement Clamping unit	Module d'arrosage Kühlmittelzufuhrelement Coolant supply unit	Page Seite Page
ML12-STAR-SR10J	ML12	> 6.27	<b>Inclus/inbegriffen/ included</b>	ML12-JET-5/16	6.38

# MODU-Line

SA-12	+ 2 outils (max 8)
Star SA-16	+ 2 Werkzeuge (max 8)
SA-16R	+ 2 tools (max 8)

**ML16**

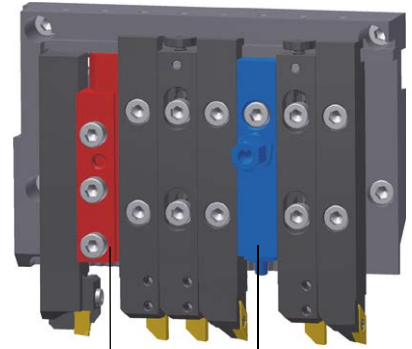
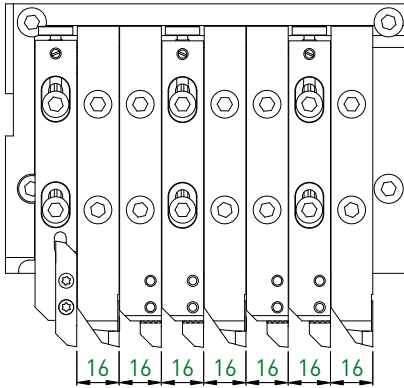

Outil  $\square$  16 mm possible avec module de serrage  
 Werkzeug  $\square$  16 mm mit Spannelement möglich  
 Tool  $\square$  16 mm possible with clamping unit

Module d'arrosage (prend la place d'un outil)  
 Kühlmittelzufuhrelement (nimmt den Platz eines Werkzeuges)  
 Coolant supply unit (takes the place of one tool)



Support de base Grundhalter Base holder		Star SA-12/SA-16/SA-16R		Accessoires Zubehöre Accessories	
Art. N°	Porte-outils Halter Holders	Pages Seiten Pages	Module de serrage Spannelement Clamping unit	Module d'arrosage Kühlmittelzufuhrelement Coolant supply unit	Page Seite Page
ML16-STAR-SA16	ML16	> 6.27	ML16-FIX-16/16	ML16-JET-7/16	6.38

**Star SB-16**

+ 3 outils (max 8)  
 + 3 Werkzeuge (max 8)  
 + 3 tools (max 8)

**ML16**

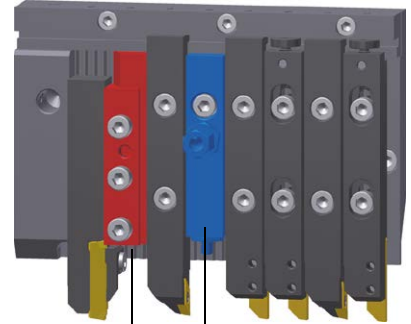
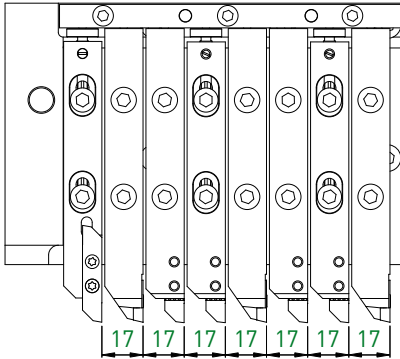

Outil  $\square$  16 mm possible avec module de serrage  
 Werkzeug  $\square$  16 mm mit Spannelement möglich  
 Tool  $\square$  16 mm possible with clamping unit

Module d'arrosage (prend la place d'un outil)  
 Kühlmittelzufuhrelement (nimmt den Platz eines Werkzeuges)  
 Coolant supply unit (takes the place of one tool)



Support de base Grundhalter Base holder		Star SB-16		Accessoires Zubehöre Accessories	
Art. N°	Porte-outils Halter Holders	Pages Seiten Pages	Module de serrage Spannelement Clamping unit	Module d'arrosage Kühlmittelzufuhrelement Coolant supply unit	Page Seite Page
<b>ML16-STAR-SB16</b>	ML16	> 6.27	<b>ML16-FIX-16/17</b>	<b>ML16-JET-7/16</b>	6.38

# MODU-Line

Star SB-20C / E

- + 1 outil (max 7)
- + 1 Werkzeug (max 7)
- + 1 tool (max 7)

**ML16**

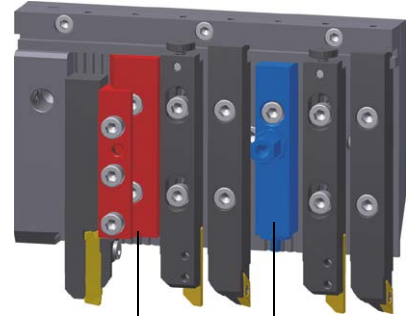
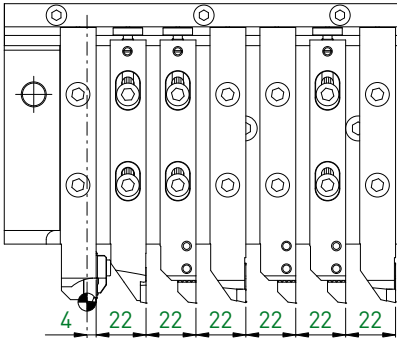

Outil  $\varnothing$  16 mm possible avec module de serrage  
 Werkzeug  $\varnothing$  16 mm mit Spannelement möglich  
 Tool  $\varnothing$  16 mm possible with clamping unit

Module d'arrosage (prend la place d'un outil)  
 Kühlmittelzufuhrelement (nimmt den Platz eines Werkzeuges)  
 Coolant supply unit (takes the place of one tool)



Support de base Grundhalter Base holder		Star SB-20C / E		Accessoires Zubehöre Accessories	
Art. N°	Porte-outils Halter Holders	Pages Seiten Pages	Module de serrage Spannelement Clamping unit	Module d'arrosage Kühlmittelzufuhrelement Coolant supply unit	Page Seite Page
ML16-STAR-SB20	ML16	> 6.27	<b>ML16-FIX-16/22</b>	<b>ML16-JET-7/16</b>	6.38



- SR-16R** + 3 outils (max 9)
- Star SR-20R** + 3 Werkzeuge (max 9)
- SR-20RII** + 3 tools (max 9)

**ML16**

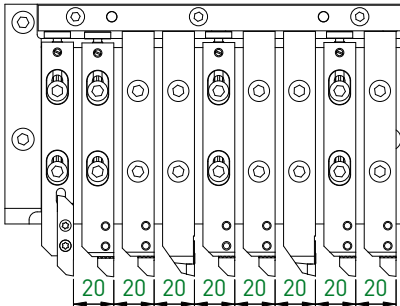

Outil  $\square$  16 mm possible avec module de serrage  
 Werkzeug  $\square$  16 mm mit Spannelement möglich  
 Tool  $\square$  16 mm possible with clamping unit

Module d'arrosage (prend la place d'un outil)  
 Kühlmittelzufuhrelement (nimmt den Platz eines Werkzeuges)  
 Coolant supply unit (takes the place of one tool)



Support de base Grundhalter Base holder		Star SR-16R/SR-20R/SR-20RII		Accessoires Zubehöre Accessories	
Art. N°	Porte-outils Halter Holders	Pages Seiten Pages	Module de serrage Spannelement Clamping unit	Module d'arrosage Kühlmittelzufuhrelement Coolant supply unit	Page Seite Page
<b>ML16-STAR-SR20R</b>	ML16	> 6.27	<b>ML16-FIX-16/20</b>	<b>ML16-JET-7/16</b>	6.38

# MODU-Line

Star SR-20RIII

+ 3 outils (max 9)

+ 3 Werkzeuge (max 9)

+ 3 tools (max 9)

ML16

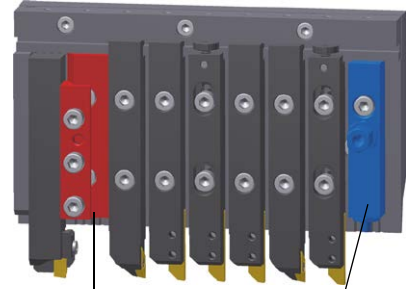
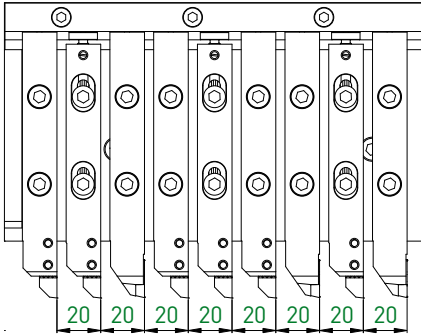

Outil  $\square$  16 mm possible avec module de serrage  
 Werkzeug  $\square$  16 mm mit Spannelement möglich  
 Tool  $\square$  16 mm possible with clamping unit

Module d'arrosage (prend la place d'un outil)  
 Kühlmittelzufuhrelement (nimmt den Platz eines Werkzeuges)  
 Coolant supply unit (takes the place of one tool)



Support de base Grundhalter Base holder		Star SR-20RIII		Accessoires Zubehöre Accessories	
Art. N°	Porte-outils Halter Holders	Pages Seiten Pages	Module de serrage Spannelement Clamping unit	Module d'arrosage Kühlmittelzufuhrelement Coolant supply unit	Page Seite Page
ML16-STAR-SR20RIII	ML16	> 6.27	ML16-FIX-16/20	ML16-JET-7/16	6.38

**Star SV12 / 20**

+ 2 outils (max 7)  
 + 2 Werkzeuge (max 7)  
 + 2 tools (max 7)

**ML16**

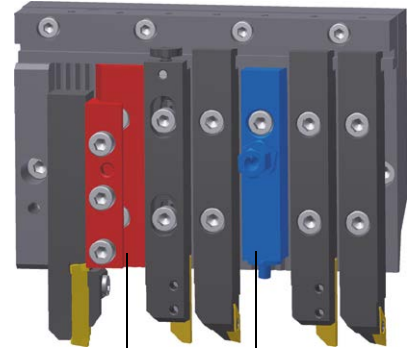
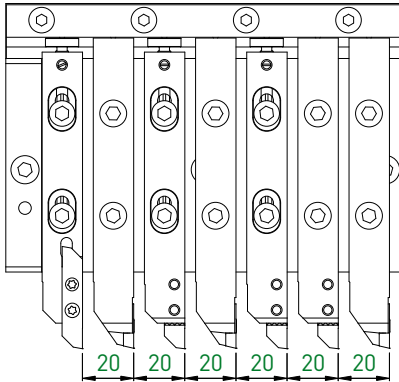

Outil  $\nabla$  16 mm possible avec module de serrage  
 Werkzeug  $\nabla$  16 mm mit Spannelement möglich  
 Tool  $\nabla$  16 mm possible with clamping unit

Module d'arrosage (prend la place d'un outil)  
 Kühlmittelzufuhrelement (nimmt den Platz eines Werkzeuges)  
 Coolant supply unit (takes the place of one tool)



Support de base Grundhalter Base holder		Star SV12 / 20		Accessoires Zubehöre Accessories	
Art. N°	Porte-outils Halter Holders	Pages Seiten Pages	Module de serrage Spannelement Clamping unit	Module d'arrosage Kühlmittelzufuhrelement Coolant supply unit	Page Seite Page
ML16-STAR-SV12/20	ML16	> 6.27	<b>ML16-FIX-16/20</b>	<b>ML16-JET-7/16</b>	6.38

Jet

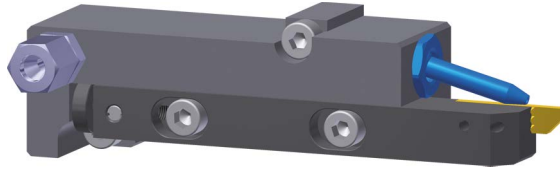

Duo

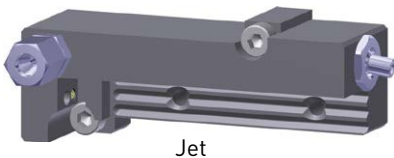
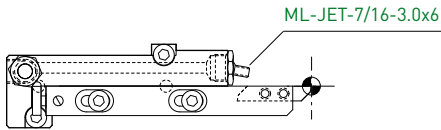

Jet

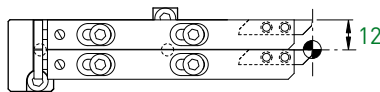

Duo

Support de base Grundhalter Base holder		Tornos DECO 7 / 10	
Type Typ Type	Art. N°	Porte-outils Halter Holders	Pages Seiten Pages
Jet	<b>ML12-DEC010-JET</b>	ML12	> 6.27
Duo	<b>ML12-DEC010-DUO</b>	ML12	> 6.27

Accessoires Zubehöre Accessories	
Buses d'arrosage Kühlmitteldüse Coolant nozzles	Page Seite Page
<b>ML-JET-7/16...</b>	6.39

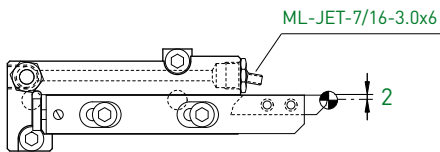

Jet

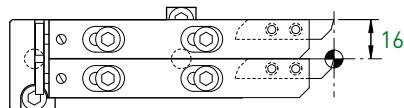

Duo

Support de base  
Grundhalter  
Base holder

Tornos DECO 13 / EvoDECO 16

Type Typ Type	Art. N°	Porte-outils Halter Holders	Pages Seiten Pages
Jet	<b>ML16-DECO13-JET</b>	ML16	> 6.27
Duo	<b>ML16-DECO13-DUO</b>	ML16	> 6.27

Accessoires  
Zubehöre  
Accessories

Buses d'arrosage  
Kühlmitteldüse  
Coolant nozzles

Page  
Seite  
Page

**ML-JET-7/16...**

6.39

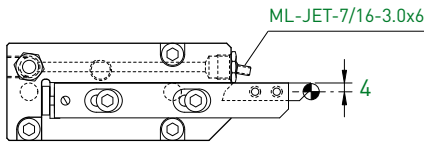

Jet

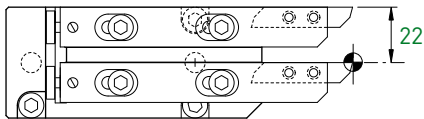

Duo

Support de base  
Grundhalter  
Base holder

Tornos DECO 20 / 26

Type Typ Type	Art. N°	Porte-outils Halter Holders	Pages Seiten Pages
Jet	<b>ML16-DEC020-JET</b>	ML16	> 6.27
Duo	<b>ML16-DEC020-DUO</b>	ML16	> 6.27

Accessoires  
Zubehöre  
Accessories

Buses d'arrosage  
Kühlmitteldüse  
Coolant nozzles

**ML-JET-7/16...**

Page  
Seite  
Page

6.39

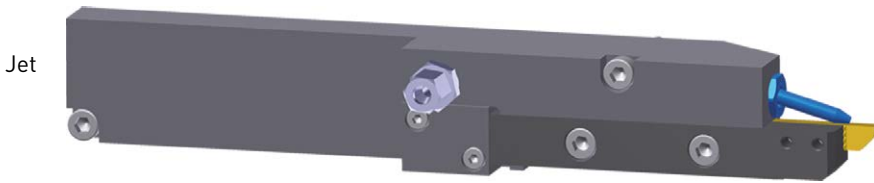

Jet

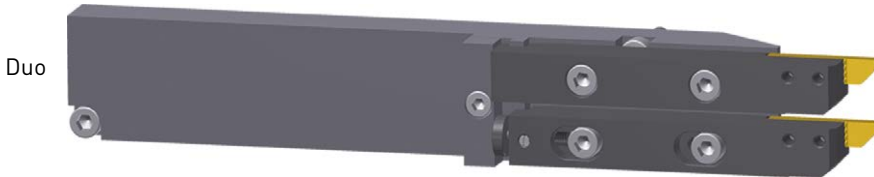

Duo

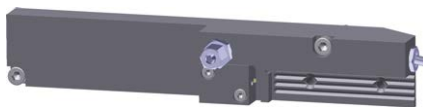
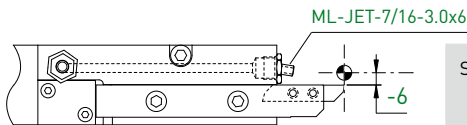

Jet

Support de base Grundhalter Base holder		Tornos SIGMA 20 / 32	
Type Typ Type	Art. N°	Porte-outils Halter Holders	Pages Seiten Pages
Jet	<b>ML16-S20-JET</b>	ML16	> 6.27
Duo	<b>ML16-S20-DUO</b>	ML16	> 6.27

Accessoires Zubehöre Accessories		Page Seite Page
Buses d'arrosage Kühlmitteldüse Coolant nozzles	<b>ML-JET-7/16...</b>	6.39

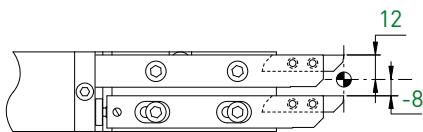

Duo

# MODU-Line

**Tornos SwissNano**

- + 2 outils (max 6)
- + 2 Werkzeuge (max 6)
- + 2 tools (max 6)

**ML12**

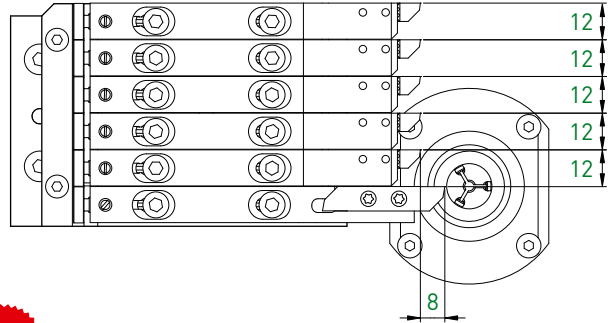

**NEW**

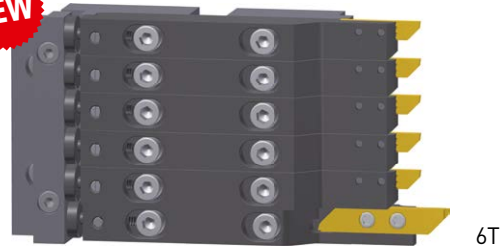

Support de base  
Grundhalter  
Base holder

Tornos SwissNano

Type Typ Type	Art. N°	Porte-outils Halter Holders	Pages Seiten Pages
6T	<b>ML12-SWISS-NANO-6T</b>	ML12	> 6.27

**Tornos SwissNano**

- Porte-outils spéciaux de tronçonnage
- Spezial Abstechwerkzeughalter
- Special parting off tool holders

**ML12**

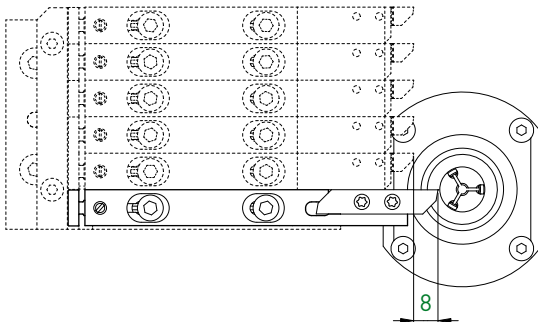



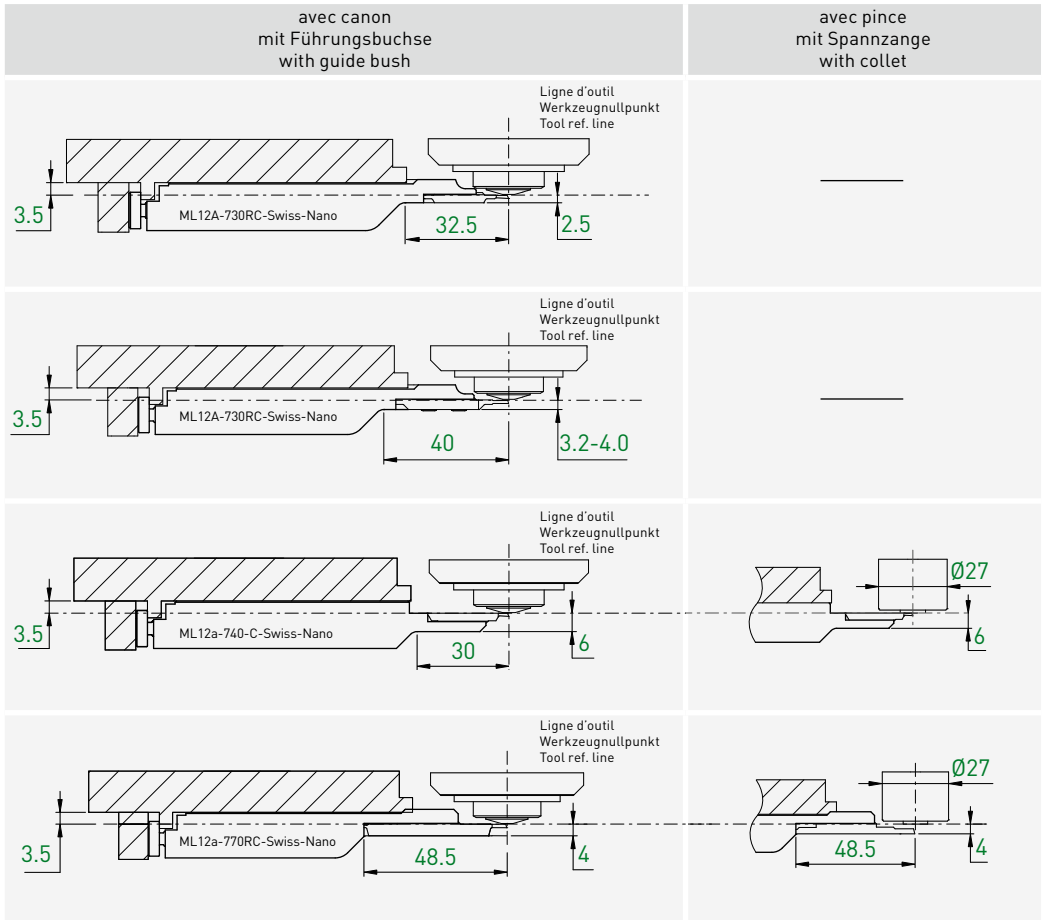

Type de machine Maschinen-Typ Type of machine	Porte-outils Halter Holders	Art. N°	Plaquettes Wendepplatten Inserts	Pages Seiten Pages
SwissNano	ML12	<b>ML12A-730RC-SWISS-NANO</b>	731R... / 731RSF	1.47-1.53 / 1.171
SwissNano	ML12	<b>ML12A-750RC-SWISS-NANO</b>	751R...	1.93-1.103
SwissNano	ML12	<b>ML12A-740-C-SWISS-NANO</b>	741... / 741SF	1.40-1.46 / 1.168
SwissNano	ML12	<b>ML12A-770RC-SWISS-NANO</b>	771R...	1.134-1.137

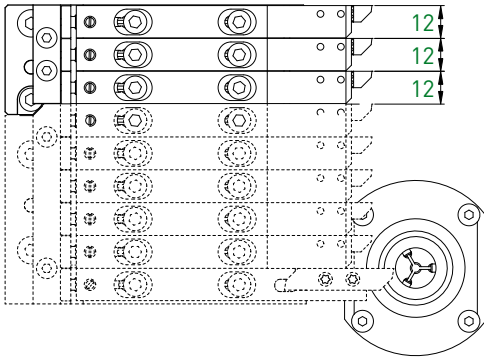
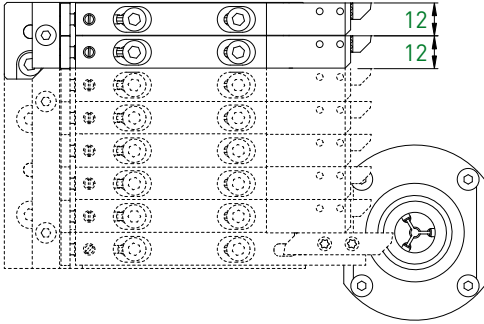

2T



3T

Support de base  
Grundhalter  
Base holder

Tornos SwissNano

Type Typ Type	Art. N°	Porte-outils Halter Holders	Pages Seiten Pages
2T	<b>ML12-SWISS-NANO-2T</b>	ML12	> 6.27
3T	<b>ML12-SWISS-NANO-3T</b>	ML12	> 6.27

Outils recommandés pour l'horlogerie  
Empfohlene Werkzeuge für Uhrenindustrie  
Recommended tools for watch industry

Porte-outils Halter Holders	Plaquettes type... WSP-Typ... Inserts type...	Pages Seiten Pages
ML12A - 740C ML12F - 740C	742SF-749SF	1.168-1.170

**Tornos DELTA 12 / 20**  
**Tsugami B012 / B020**

+ 2 x 1 outil  
+ 2 x 1 Werkzeug  
+ 2 x 1 tool

**ML20**

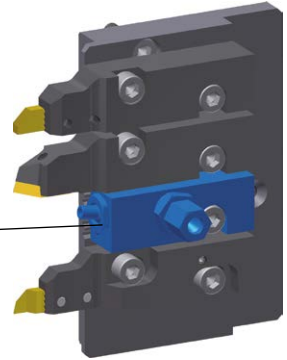
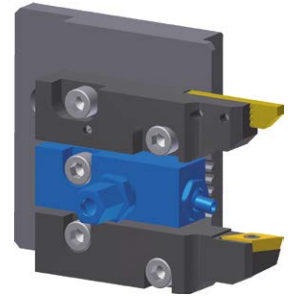
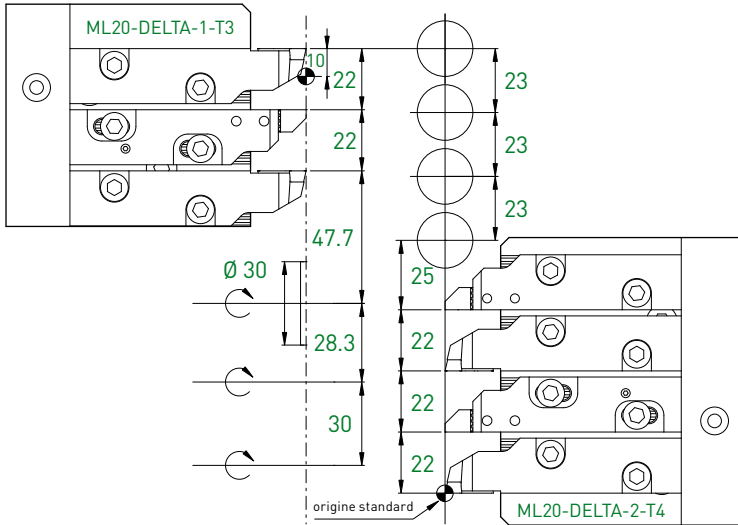

Module d'arrosage (prend la place d'un outil)  
Kühlmittelzufuhrelement (nimmt den Platz eines Werkzeuges)  
Coolant supply unit (takes the place of one tool)

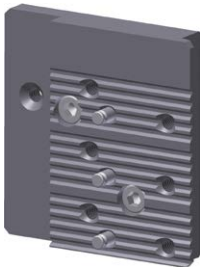

T3

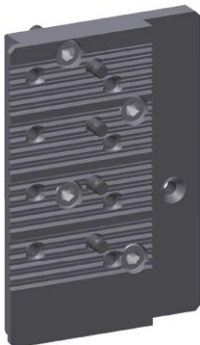

T4

Support de base  
Grundhalter  
Base holder

Tornos DELTA 12 / 20  
Tsugami B012 / B020

Type Typ Type	Art. N°	Porte-outils Halter Holders	Pages Seiten Pages
T3	<b>ML20-DELTA-1-T3</b>	ML20	> 6.27
T4	<b>ML20-DELTA-2-T4</b>	ML20	> 6.27

Accessoires  
Zubehöre  
Accessories

Buses d'arrosage  
Kühlmitteldüse  
Coolant nozzles

**ML20-JET-7/16**

Page  
Seite  
Page

6.39

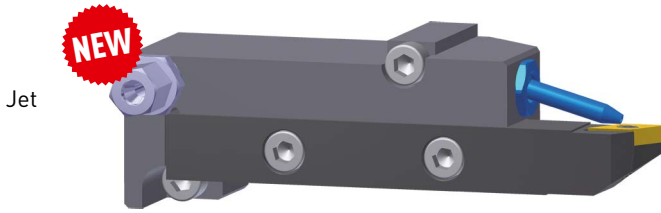

Jet



Duo

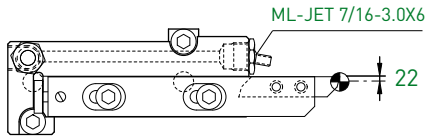

Jet

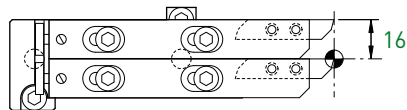

Duo

Support de base Grundhalter Base holder		Tornos Swiss ST26	
Type Typ Type	Art. N°	Porte-outils Halter Holders	Pages Seiten Pages
Jet	<b>ML16-SWISS-ST26-JET</b>	ML16	> 6.27
Duo	<b>ML16-SWISS-ST26-DUO</b>	ML16	> 6.27

Accessoires Zubehöre Accessories	
Buses d'arrosage Kühlmitteldüse Coolant nozzles	Page Seite Page
<b>ML-JET-7/16...</b>	6.39

Porte-plaquettes

WSP-Halter

Insert holders

## ML12 / ML16 / ML20

Système de fixation  
Befestigungssystem  
Clamping system

A = réglable  
einstellbar  
adjustable

F = longueur fixe  
fixlänge  
fixed length

ML12A

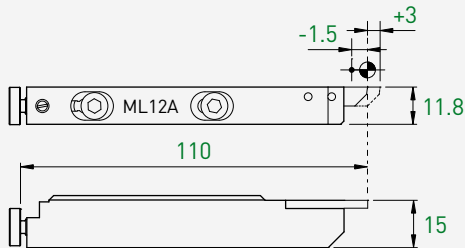

ML12F

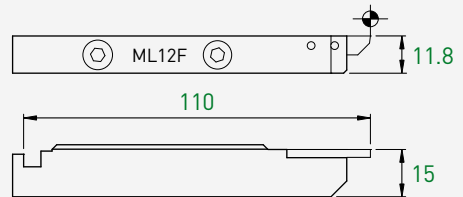

ML16A

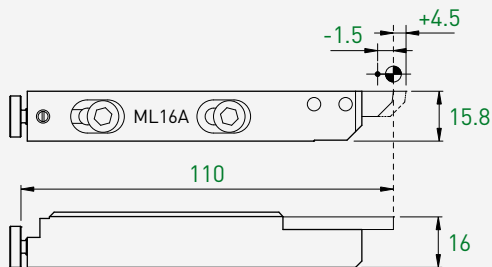

ML16F

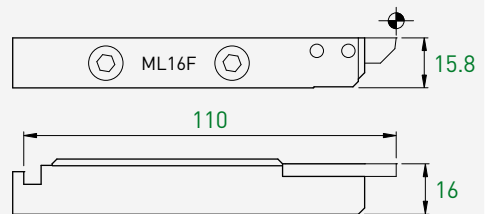

ML20A

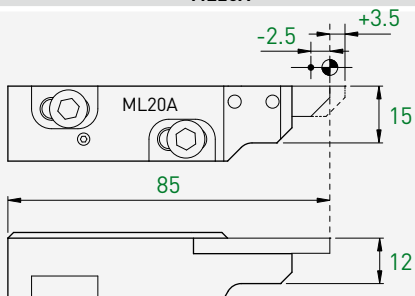

ML20F

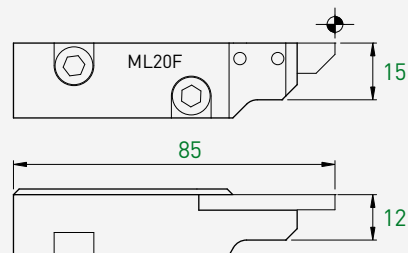

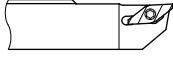

ML12	ML16	ML20	Plaquettes type... WSP-Typ... Inserts type...	Pages Seiten Pages
Art. N°	Art. N°	Art. N°		
ML12A-340	ML16A-340	ML20A-340	TOP-Line 347-349	1.18-1.19
ML12F-340	ML16F-340	ML20F-340		

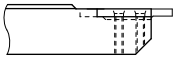

ML12	ML16	ML20	TOP-Line 741-747	> 1.33
ML12A-740	ML16A-740	ML20A-740		
ML12F-740	ML16F-740	ML20F-740		

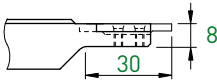

ML12	ML16	ML20	TOP-Line 741-747	> 1.33
ML12A-740-C	-	ML20A-740-C		
ML12F-740-C	-	-		

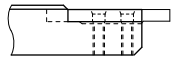

ML12	ML16	ML20	TOP-Line 761-767	> 1.77
ML12A-760	ML16A-760	ML20A-760		
ML12F-760	ML16F-760	ML20F-760		

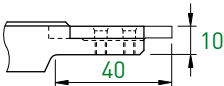

ML12	ML16	ML20	TOP-Line 761-767	> 1.77
-	ML16A-760-C	-		
-	ML16F-760-C	-		

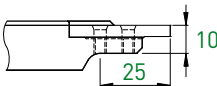

ML12	ML16	ML20	TOP-Line 761-767	> 1.77
-	-	ML20A-760-C		
-	-	ML20F-760-C		

Porte-plaquette

WSP-Halter

Insert holder

ECO



ML12	ML16	ML20	Plaquettes type... WSP-Typ... Inserts type...	Pages Seiten Pages
Art. N°	Art. N°	Art. N°		
ML12A-260	ML16A-260	-	ECO-Line 261-266	> 3.01
ML12F-260	ML16F-260	-		

Porte-plaquettes

WSP-Halter

Insert holders

CUT

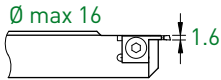

ML12	ML16	ML20	Plaquettes type... WSP-Typ... Inserts type...	Pages Seiten Pages
Art. N°	Art. N°	Art. N°		
ML12A-CUT16	ML16A-CUT16	-	CUT-Line CUT16	5.14-5.17
ML12F-CUT16	ML16F-CUT16	-		

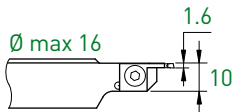

ML12	ML16	ML20	Plaquettes type... WSP-Typ... Inserts type...	Pages Seiten Pages
-	-	ML20A-CUT16		
-	-	-		

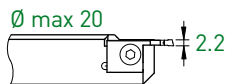

ML12	ML16	ML20	Plaquettes type... WSP-Typ... Inserts type...	Pages Seiten Pages
ML12A-CUT22	ML16A-CUT22	-		
ML12F-CUT22	ML16F-CUT22	-		

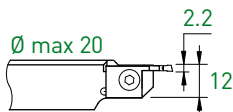

ML12	ML16	ML20	Plaquettes type... WSP-Typ... Inserts type...	Pages Seiten Pages
-	-	ML20A-CUT22		
-	-	-		



ML12	ML16	ML20	Plaquettes type... WSP-Typ... Inserts type...	Pages Seiten Pages
Art. N°	Art. N°	Art. N°		
ML12A-SCLCR06	ML16A-SCLCR06	-	ISO-Line CC..-0602..	4.14-4.17
ML12F-SCLCR06	ML16F-SCLCR06	-		

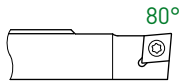

ML12	ML16	ML20	ISO-Line CC..-09T3..	4.17-4.17
ML12A-SCLCR09	ML16A-SCLCR09	ML20A-SCLCR09		
ML12F-SCLCR09	ML16F-SCLCR09	ML20F-SCLCR09		

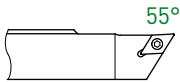

ML12	ML16	ML20	ISO-Line DC..-0702..	4.22-4.25
ML12A-SDJCR07	ML16A-SDJCR07	-		
ML12F-SDJCR07	ML16F-SDJCR07	-		

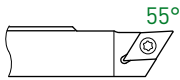

ML12	ML16	ML20	ISO-Line DC..-11T3..	4.22-4.25
ML12A-SDJCR11	ML16A-SDJCR11	ML20A-SDJCR11		
ML12F-SDJCR11	ML16F-SDJCR11	ML20F-SDJCR11		

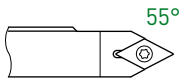

ML12	ML16	ML20	ISO-Line DC..-11T3..	4.22-4.25
ML12A-SDNCN11	ML16A-SDNCN11	-		
ML12F-SDNCN11	ML16F-SDNCN11	-		



Porte-plaquettes

WSP-Halter

Insert holders

ISO

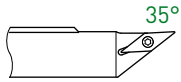

ML12	ML16	ML20	Plaquettes type... WSP-Typ... Inserts type...	Pages Seiten Pages
Art. N°	Art. N°	Art. N°		
ML12A-SVJCR11 ML12F-SVJCR11	ML16A-SVJCR11 ML16F-SVJCR11	ML20A-SVJCR11 ML20F-SVJCR11	ISO-Line VC...-1103..	4.30-4.35

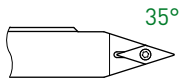

ML12	ML16	ML20	ISO-Line VC...-1103..	4.31-4.35
ML12A-SVVCN11 ML12F-SVVCN11	ML16A-SVVCN11 ML16F-SVVCN11	- -		

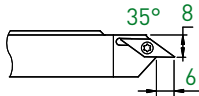

ML12	ML16	ML20	ISO-Line VC...-1103..	4.30-4.35
ML12A-SV-CR11 -	ML16A-SV-CR11 -	- -		

# MODU-Line

Porte-plaquettes

WSP-Halter

Insert holders

TOP

Coupe à droite déportée ou usinage à gauche sur contre-broche

Rechtsschneidend versetzt oder linksschneidend auf Gegenspindel

Right hand cut off line or left hand cutt on subspindle

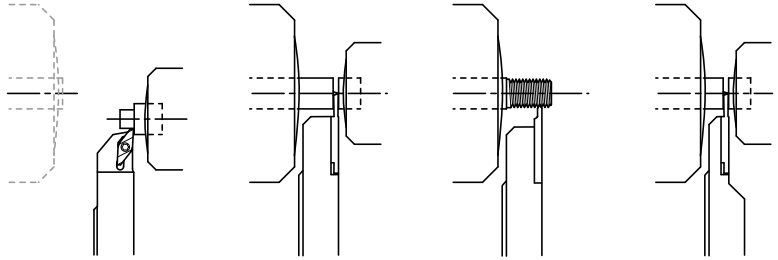

330-V

730-V  
750-V

730-V  
750-V

730-RC  
750-RC

Porte-plaquettes

WSP-Halter

Insert holders

TOP



ML12	ML16	ML20	Plaquettes type... WSP-Typ... Inserts type...	Pages Seiten Pages
Art. N°	Art. N°	Art. N°		
ML12A-330-V	ML16A-330-V	-	TOP-Line 337-339	1.18-1.19



ML12	ML16	ML20	731R 731-737	1.47-1.53 > 1.33
ML12A-730-V	ML16A-730-V	-		

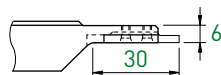

ML12	ML16	ML20	TOP-Line 731R	1.47-1.53
ML12A-730RC	ML16A-730RC	-		



ML12	ML16	ML20	TOP-Line 751R 751-757	1.93-1.103 > 1.77
ML12A-750-V	ML16A-750-V	-		

Porte-plaquettes

WSP-Halter

Insert holders

TOP

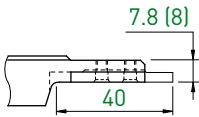

ML12	ML16	ML20	Plaquettes type... WSP-Typ... Inserts type...	Pages Seiten Pages
Art. N°	Art. N°	Art. N°		
ML12A-750RC	ML16A-750RC	-	TOP-Line 751R	1.93-1.103

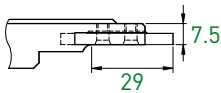

ML12	ML16	ML20	Plaquettes type... WSP-Typ... Inserts type...	Pages Seiten Pages
Art. N°	Art. N°	Art. N°		
-	-	ML20A-750RC	TOP-Line 751R	1.93-1.103

Porte-plaquettes

WSP-Halter

Insert holders

ECO



ML12	ML16	ML20	Plaquettes type... WSP-Typ... Inserts type...	Pages Seiten Pages
Art. N°	Art. N°	Art. N°		
ML12A-250-V	ML16A-250-V	-	ECO-Line type 251R 251-256	3.08-3.09 > 3.01
-	-	-		

Ø max 16

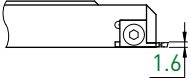

ML12	ML16	ML20	Plaquettes type... WSP-Typ... Inserts type...	Pages Seiten Pages
Art. N°	Art. N°	Art. N°		
ML12A-CUT16-V	ML16A-CUT16-V	-	CUT-Line CUT16	5.14-5.17
ML12F-CUT16-V	ML16F-CUT16-V	-		

Ø max 16

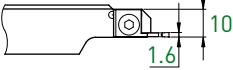

ML12	ML16	ML20	Plaquettes type... WSP-Typ... Inserts type...	Pages Seiten Pages
-	-	ML20A-CUT16RC		
-	-	-		

Ø max 20

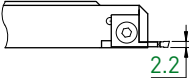

ML12	ML16	ML20	Plaquettes type... WSP-Typ... Inserts type...	Pages Seiten Pages
ML12A-CUT22-V	ML16A-CUT22-V	-		
ML12F-CUT22-V	ML16F-CUT22-V	-		

Ø max 20

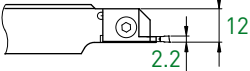

ML12	ML16	ML20	Plaquettes type... WSP-Typ... Inserts type...	Pages Seiten Pages
-	-	ML20A-CUT22RC		
-	-	-		

Porte-plaquettes

WSP-Halter

Insert holders

ISO



ML12	ML16	ML20	Plaquettes type... WSP-Typ... Inserts type...	Pages Seiten Pages
Art. N°	Art. N°	Art. N°		
<b>ML12A-SDJCL11-V</b>	<b>ML16A-SDJCL11-V</b>	-	ISO-Line DC..-11T3..	4.22-4.25
-	-	-		

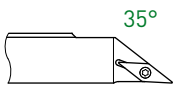

ML12	ML16	ML20	ISO-Line VC..-1103..	4.30-4.35
Art. N°	Art. N°	Art. N°		
<b>ML12A-SVJCL11-V</b>	<b>ML16A-SVJCL11-V</b>	-	ISO-Line VC..-1103..	4.30-4.35
-	-	-		

# MODU-Line

Porte-outils

Halter

Holder

ML12 / ML16 / ML20

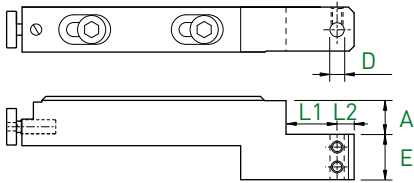

A	D	E	L1	L2	ML12
					Art. N°
8	3	12	13	6	ML12A-2440-8-3
8	4	12	13	6	ML12A-2440-8-4
8	5	12	13	6	ML12A-2440-8-5
12	6	12	13	6	ML12A-2440-12-6

A	D	E	L1	L2	ML16
					Art. N°
12	3	16	18	6	ML16A-2440-12-3
12	4	16	18	6	ML16A-2440-12-4
12	5	16	18	6	ML16A-2440-12-5
12	6	16	18	6	ML16A-2440-12-6
18	8	16	18	6	ML16A-2440-18-8

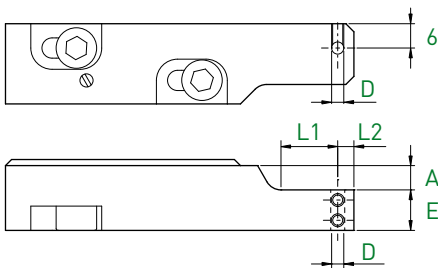

A	D	E	L1	L2	ML20
					Art. N°
6	3	10	14	4	ML20A-2440-6-3
8	4	8	14	4	ML20A-2440-8-4

Porte-molettes

Rändelhalter

Knurl holders

## ML12 / ML16 / ML20

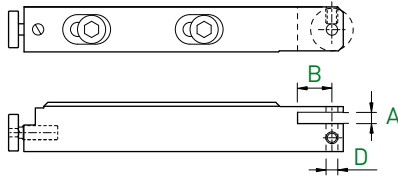

			ML12
A	D	B	Art. N°
4	4	8	ML12A-2402-44

			ML16
A	D	B	Art. N°
4	4	11	ML16A-2402-44

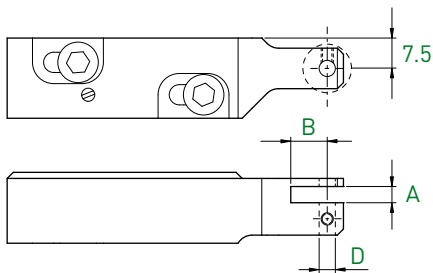

			ML20
A	D	B	Art. N°
4	4	9	ML20A-2402-44

# MODU-Line

Modules d'arrosage

Kühlmittelzufuhrelemente

Coolant supply units

## ML12 / ML16 / ML20

ML12

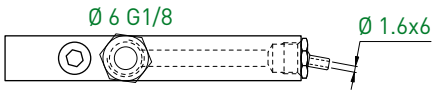

Raccord Anschluss Connection	Buses d'arrosage Kühlmitteldüse Coolant nozzles	ML12 Art. N°
Ø 6 G 1/8	5/16"	ML12-JET-5/16

ML16

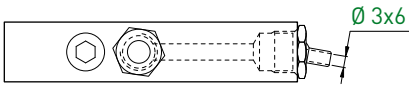

Raccord Anschluss Connection	Buses d'arrosage Kühlmitteldüse Coolant nozzles	ML16 Art. N°
Ø 6 G 1/8	7/16"	ML16-JET-7/16

ML20

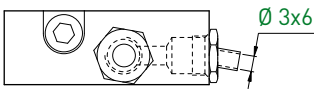

Raccord Anschluss Connection	Buses d'arrosage Kühlmitteldüse Coolant nozzles	ML20 Art. N°
Ø 6 G 1/8	7/16"	ML20-JET-7/16

buses optionnelles voir page 6.39  
zusätzliche Düsen siehe Seite 6.39  
optional nozzles see page 6.39

Modules de serrage

Spannelemente

Clamping units

## ML12 / ML16

ML12

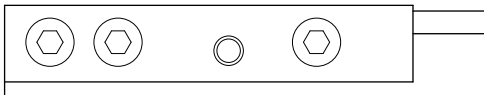

ML12 Art. N°
ML12-FIX-12/14

ML16

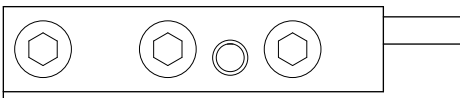

ML16 Art. N°
ML16-FIX-16/16
ML16-FIX-16/16.5
ML16-FIX-16/17
ML16-FIX-16/20
ML16-FIX-16/22



Buses d'arrosage

Kühlmitteldüsen

Coolant nozzles

5/16" / 7/16"

JET

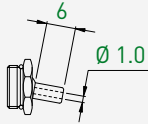
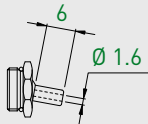
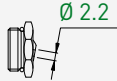
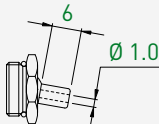
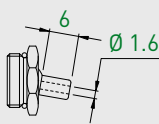
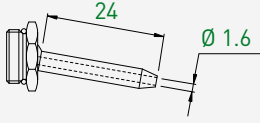
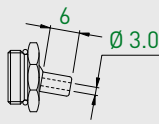
5/16"	Art. N°	Références compatibles Kompatible Artikeln Compatible items
	ML-JET 5/16-1.0x6	ML12-JET-5/1
	ML-JET 5/16-1.6x6	une buse ML-JET 5/16 1.6x6 est comprise eine Düse ML-JET 5/16 1.6x6 ist inbegriffen a nozzle ML-JET 5/16 1.6 x6 is included
	ML-JET 5/16-2.2x0	
7/16"	Art. N°	Références compatibles Kompatible Artikeln Compatible items
	ML-JET 7/16-1.0x6	ML12-SWISS-NANO-6T ML16-SWISS-NANO-JET ML16-KMX26-JET ML16-JET-7/16 ML20-JET-7/16 ML12-CITIZEN-C16 ML12-DECO10-JET ML16-DECO13-JET ML16-DECO20-JET ML16-S20-JET
	ML-JET 7/16-1.6x6	
	ML-JET-7/16-1.6x24	une buse ML-JET-7/16 3.0x6 est comprise avec chaque article ci-dessus eine Düse ML-JET 7/16 3.0x6 ist mit jedem vorstehenden Artikel inbegriffen
	ML-JET-7/16-3.0x6	a nozzle ML-JET 7/16 3.0x6 is included with each above item

# MODU-Line

Banc de pré réglage

Voreinstellgerät

Presetting device

ML12 / ML16 / ML20

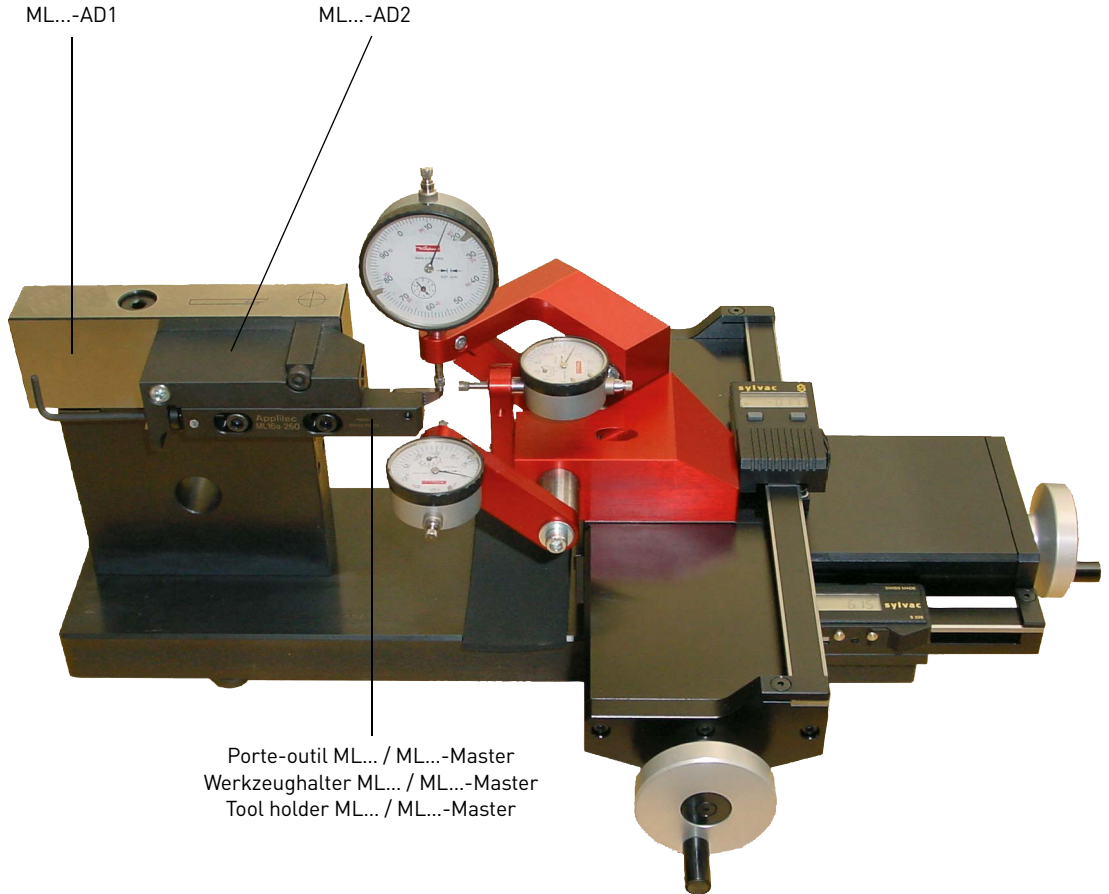

Art. N°

ML-PRESET-1

**Banc de préélagage**

**Voreinstellgerät**

**Presetting device**

**ML12 / ML16 / ML20**

Type  
Typ  
Type

Machines  
Maschinen  
Machines

Adaptateurs et jauges d'étalonnage  
Adapter und Einstelllehre  
Adaptators and master gauges

ML12

CITIZEN C12 / C16  
HANWHA XD20M  
STAR SR-10J  
TORNOS DECO 7/10  
TORNOS SWISSNANO

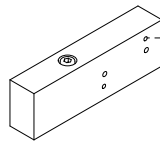

ML12-AD1



ML12-AD2

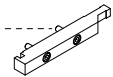

ML12-MASTER

ML16

CITIZEN K12 / K16 type VII  
CITIZEN L16 / L20 type VII / VIII  
HANWHA SL12 / 16  
MANURHIN KMX 426 / 526 / 626  
MANURHIN SWING 20 - 26 mm  
STAR SA-12 / SA-16 / SA-16R  
STAR SB-16  
STAR SB-20C ( E )  
STAR SR-16R  
STAR SR-20R / SR-20RII / SR-20-RIII  
STAR SV12 / 20  
TORNOS DECO 20 / 26  
TORNOS DECO SIGMA 20

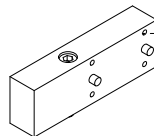

ML16/20-AD1

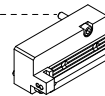

ML16-AD2

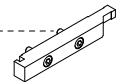

ML16-MASTER

ML16

TORNOS DECO 13  
TORNOS ST 26

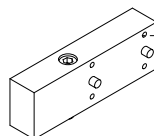

ML16-DECO13-AD1

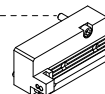

ML16-DECO13-AD2

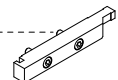

ML16-MASTER

ML20

TORNOS DELTA 12 / 20  
TSUGAMI B012 / B020

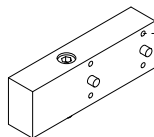

ML16/20-AD1

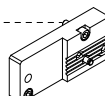

ML20-AD2



ML20-MASTER

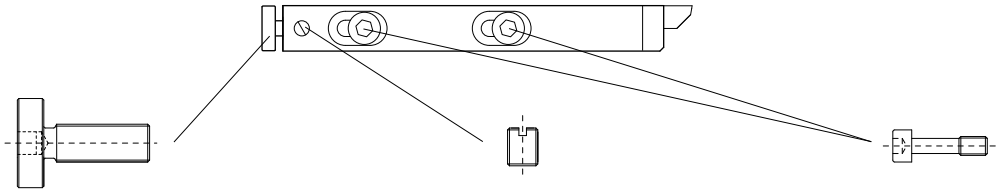

Vis de réglage  
Einstellungsschraube  
Setting screw

Art. N°

ML12A-M5X0.5

Vis de blocage  
Blockierschraube  
Locking screw

Art. N°

ML-M4X4-T

Vis de fixation  
Befestigungsschraube  
Fixing screw

Art. N°

ML12-M5XL20

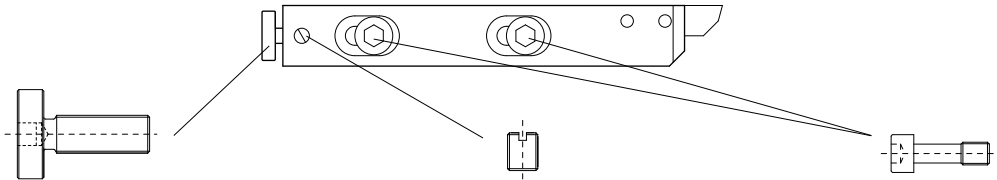

Vis de réglage  
Einstellungsschraube  
Setting screw

Art. N°

ML16A-M5X0.5

Vis de blocage  
Blockierschraube  
Locking screw

Art. N°

ML-M4X4-T

Vis de fixation  
Befestigungsschraube  
Fixing screw

Art. N°

ML16/20-M6XL20

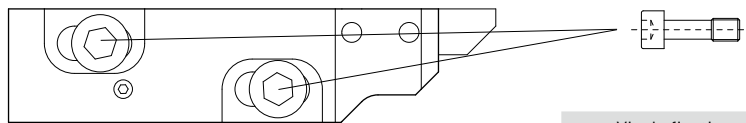

Vis de fixation  
Befestigungsschraube  
Fixing screw

Art. N°

ML16/20-M6-XL20



Pièces de rechange

Ersatzteile

Spare parts

## ML12 / ML16 / ML20

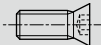
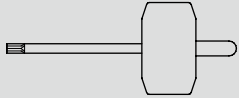
Vis et clés pour le serrage des plaquettes  
Schrauben und Schlüssel für WSP-Befestigung  
Screws and keys for insert clamping

Porte-outils Halter Holders			
ML...-250	<b>V-M4x9-T15</b>	<b>C-T15</b>	-
ML...-260	<b>V-M4x9-T15</b>	<b>C-T15</b>	-
ML...-330	<b>V-M2.5x7.8-T8</b>	<b>C-T8</b>	-
ML...-340	<b>V-M2.5x7.8-T8</b>	<b>C-T8</b>	-
ML...-730	<b>V-M3x7-T8</b>	<b>C-T8</b>	-
ML...-730RC	<b>V-M3x5.5-T8</b>	<b>C-T8</b>	-
ML...-740	<b>V-M3x7-T8</b>	<b>C-T8</b>	-
ML...-750	<b>V-M4x9-T15</b>	<b>C-T15</b>	-
ML...-750RC	<b>V-M4x7.3-T15</b>	<b>C-T15</b>	-
ML...-760	<b>V-M4x9-T15</b>	<b>C-T15</b>	-
ML...-SC...06	<b>V-M2.5x7.8-T8</b>	<b>C-T8</b>	-
ML...SC...09	<b>V-M4x9-T15-ISO</b>	<b>C-T15</b>	-
ML...-SD...07	<b>V-M2.5x7.8-T8</b>	<b>C-T8</b>	-
ML...-SD...11	<b>V-M4x9-T15-ISO</b>	<b>C-T15</b>	-
ML...-SV...11	<b>V-M2.5x7.8-T8</b>	<b>C-T8</b>	-
ML12 / ML16...- CUT16	-	-	<b>CUT16 RS-SET</b>
ML20...CUT16	-	-	<b>CUT16 R-SET</b>
ML20...CUT16-RC	-	-	<b>CUT16 L-SET</b>
ML12 / ML16...-CUT16-V	-	-	<b>CUT16 LS-SET</b>
ML12 / ML16...-CUT22	-	-	<b>CUT22 RS-SET</b>
ML20...-CUT22	-	-	<b>CUT22 R-SET</b>
ML20...-CUT22-RC	-	-	<b>CUT22 L-SET</b>
ML12 / ML16...-CUT22-V	-	-	<b>CUT22 LS-SET</b>

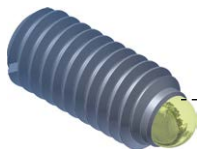

Art. N°

**ML-205004**

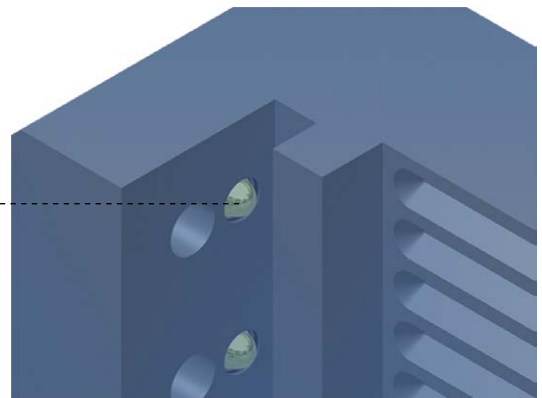

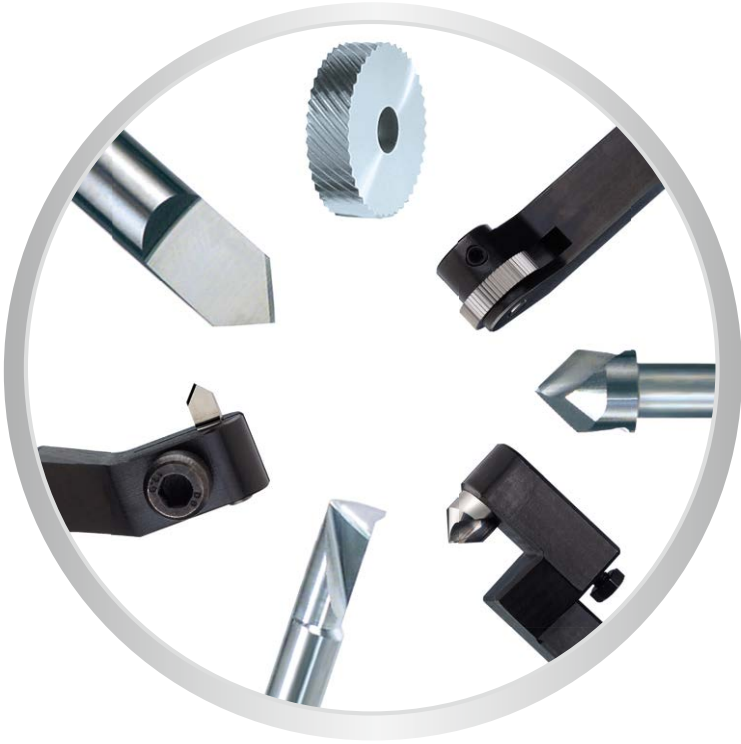

Porte-outils  
Werkzeughalter  
Tool holders

**Type 14xx / 24xx**



> **7.02**

Porte-outils monoblocs pour machines Tornos  
Monoblockwerkzeughalter für Tornos Maschinen  
Monobloc tool holders for Tornos machines

**Type 2435 / 2436**

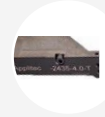

> **7.12**

Forets à centrer plats  
Zentrierflachbohrer  
Centering flat drills

**Type 12xx / 22xx**



> **7.14**

Forets à centrer hélicoïdaux  
Zentrierspiralbohrer  
Centering twist drills

**Type 15xx / 25xx**



> **7.15**

Burins intérieurs en métal dur  
Vollhartmetall Innendrehwerkzeuge  
Solid carbide internal turning tools

**Type 16xx / 26xx**

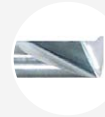

> **7.16**

Porte-molettes  
Rändelhalter  
Knurl holders

**Type 1402 / 2402**



> **7.18**

Molettes en métal dur  
Vollhartmetall Rändelrädchen  
Solid carbide knurling wheels

**Type 1107**



> **7.19**

# TOOLING-Line

Porte-outils

Werkzeughalter

Tool holders

1400-J / 2400-J

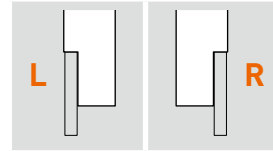
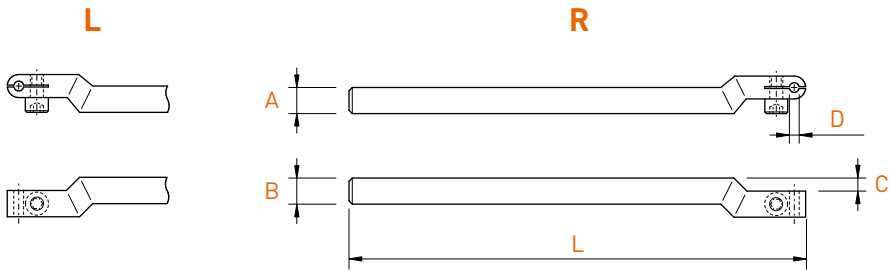

A x B	L	C	D	Art. N°	Art. N°
6 x 6	132	3	1.5	1400-J-615	2400-J-615
6 x 6	132	3	2.0	1400-J-620	2400-J-620
6 x 6	132	3	3.0	1400-J-630	2400-J-630
7 x 7	140	3	1.5	1400-J-715	2400-J-715
7 x 7	140	3	2.0	1400-J-720	2400-J-720
7 x 7	140	3	3.0	1400-J-730	2400-J-730
8 x 8	140	4	1.5	1400-J-815	2400-J-815
8 x 8	140	4	2.0	1400-J-820	2400-J-820
8 x 8	140	4	3.0	1400-J-830	2400-J-830



Porte-outils

Werkzeughalter

Tool holders

## 1401-K / 2401-K

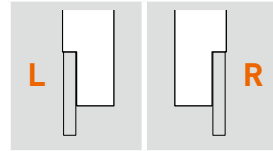
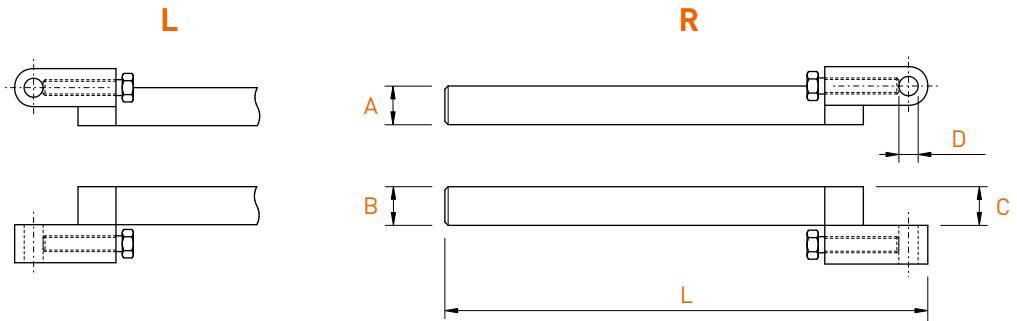

A x B	L	C	D	Art. N°	Art. N°
7 x 7	146	7	3.0	1401-K-720	-
7 x 7	146	7	3.0	1401-K-730	2401-K-730
7 x 7	146	7	4.0	1401-K-740	2401-K-740
7 x 7	146	7	4.0	1401-K-820	-
8 x 8	146	8	3.0	1401-K-830	2401-K-830
8 x 8	146	8	4.0	1401-K-840	2401-K-840
8 x 8	146	8	5.0	1401-K-850	2401-K-850
8 x 8	146	8	6.0	1401-K-860	2401-K-860
10 x 10	150	10	3.0	-	2401-K-1030
10 x 10	150	10	4.0	1401-K-1040	2401-K-1040
10 x 10	150	10	5.0	1401-K-1050	2401-K-1050
10 x 10	150	10	6.0	1401-K-1060	2401-K-1060
10 x 10	150	10	7.0	1401-K-1070	2401-K-1070
12 x 12	150	12	3.0	-	2401-K-1230
12 x 12	150	12	4.0	1401-K-1240	2401-K-1240
12 x 12	150	12	5.0	1401-K-1250	2401-K-1250
12 x 12	150	12	6.0	1401-K-1260	2401-K-1260
12 x 12	150	12	8.0	1401-K-1280	2401-K-1280
14 x 14	150	14	4.0	1401-K-1440	2401-K-1440
14 x 14	150	14	6.0	1401-K-1460	2401-K-1460
14 x 14	150	14	8.0	1401-K-1480	2401-K-1480

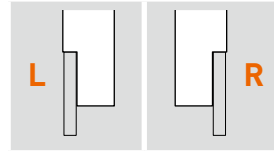
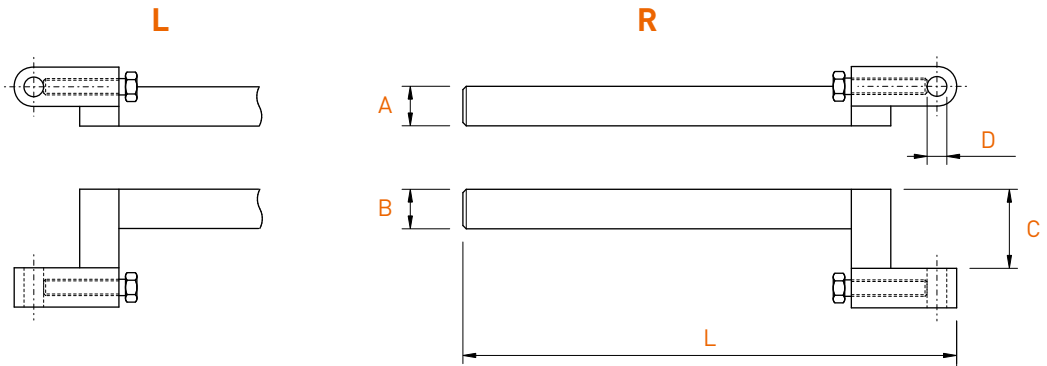

A x B	L	C	D	Art. N°	Art. N°
7 x 7	146	12	4.0	1420-7124	2420-7124
8 x 8	146	12	4.0	1420-8124	2420-8124
8 x 8	146	14	3.0	1420-8143	2420-8143
8 x 8	146	15	5.0	1420-8155	2420-8155
8 x 8	146	20	5.0	1420-8205	2420-8205
10 x 10	150	20	6.0	1420-10206	2420-10206
12 x 12	150	18	6.0	1420-12186	2420-12186
12 x 12	150	18	8.0	1420-12188	-
12 x 12	150	24	8.0	1420-12248	2420-12248
14 x 14	150	20	8.0	1420-14208	2420-14208
14 x 14	150	24	8.0	1420-14248	2420-14248

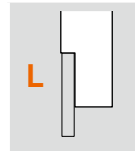
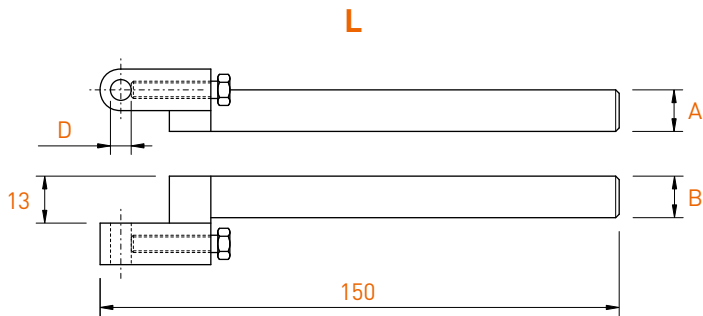

A x B	D	Art. N°
12 x 12	4.0	<b>1460-4</b>
12 x 12	5.0	<b>1460-5</b>
12 x 12	6.0	<b>1460-6</b>
12 x 12	8.0	<b>1460-8</b>

# TOOLING-Line

Porte-outils

Werkzeughalter

Tool holders

∅ 10 x 10

2450-SP

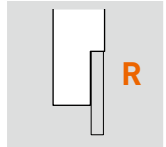
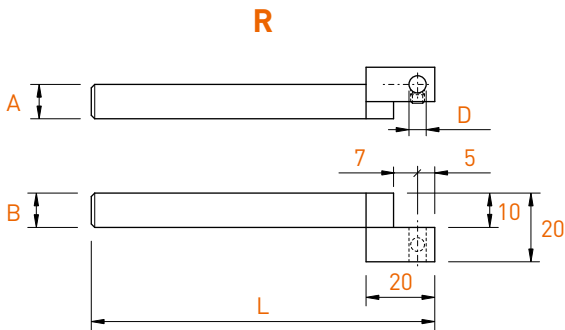

A x B	L	D	Art. N°
10 x 10	100	3.0	2450-SP-3
10 x 10	100	4.0	2450-SP-4
10 x 10	100	5.0	2450-SP-5
10 x 10	100	6.0	2450-SP-6
10 x 10	120	3.0	2450-SP-3-120
10 x 10	120	4.0	2450-SP-4-120
10 x 10	120	5.0	2450-SP-5-120
10 x 10	120	6.0	2450-SP-6-120

Porte-outils

Werkzeughalter

Tool holders

∅ 10 x 10

2470

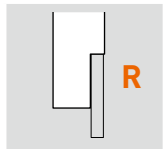
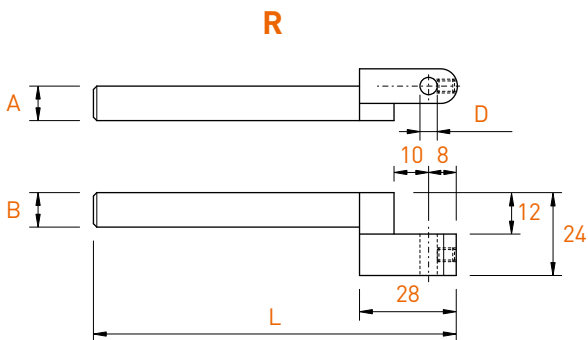

A x B	L	D	Art. N°
10 x 10	105	3.0	2470-3
10 x 10	105	4.0	2470-4
10 x 10	105	5.0	2470-5
10 x 10	105	6.0	2470-6
10 x 10	105	7.0	2470-7

Porte-outils  
Werkzeughalter  
Tool holders

∅ 12 x 12

2450

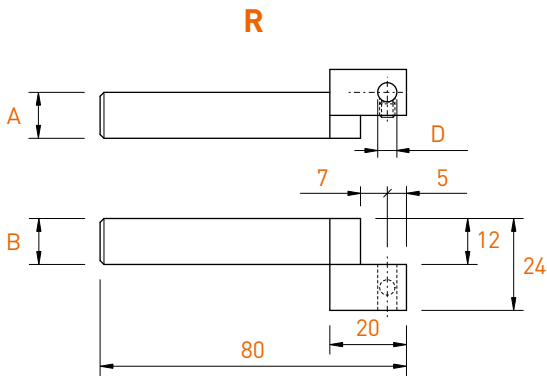

A x B	D	Art. N°
12 x 12	3.0	2450-3
12 x 12	4.0	2450-4
12 x 12	5.0	2450-5
12 x 12	6.0	2450-6
12 x 12	8.0	2450-8

Porte-outils  
Werkzeughalter  
Tool holders

∅ 12 x 12

2460

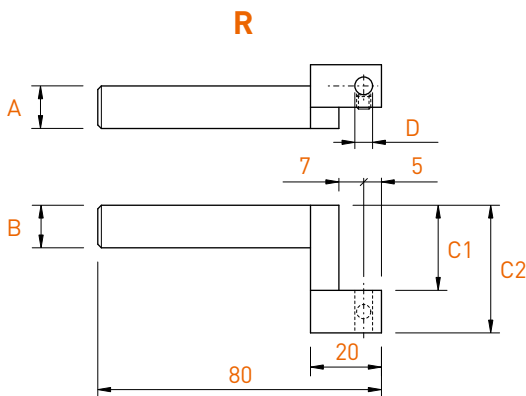

A x B	C1	C2	D	Art. N°
12 x 12	16	28	4.0	2460-284
12 x 12	16	28	6.0	2460-286
12 x 12	16	28	8.0	2460-288
12 x 12	20	32	4.0	2460-324
12 x 12	20	32	6.0	2460-326
12 x 12	20	32	8.0	2460-328
12 x 12	24	36	4.0	2460-364
12 x 12	24	36	6.0	2460-366
12 x 12	24	36	8.0	2460-368



A x B	L	C	D	Art. N°
8 x 8	120	8	3.0	2405-K-830
8 x 8	120	8	4.0	2405-K-840
8 x 8	120	8	5.0	2405-K-850
8 x 8	120	8	6.0	2405-K-860
10 x 10	100	10	4.0	2405-K-1040
10 x 10	100	10	5.0	2405-K-1050
10 x 10	100	10	6.0	2405-K-1060
12 x 12	150	12	4.0	2405-K-1240
12 x 12	150	12	6.0	2405-K-1260
12 x 12	150	12	8.0	2405-K-1280

Porte-outils

Werkzeughalter

Tool holders

2425



A x B	L	C	D	Art. N°
8 x 8	120	12	4.0	2425-8124
8 x 8	120	15	5.0	2425-8155
8 x 8	120	20	5.0	2425-8205
10 x 10	100	15	6.0	2425-10156
10 x 10	100	20	6.0	2425-10206
12 x 12	150	18	6.0	2425-12186
12 x 12	150	24	8.0	2425-12248

# TOOLING-Line

Porte-outils

Werkzeughalter

Tool holders

12 x 16

2441



A x B	D	Art. N°
12 x 16	3.0	2441-0-3
12 x 16	4.0	2441-0-4
12 x 16	5.0	2441-0-5
12 x 16	6.0	2441-0-6

Porte-outils

Werkzeughalter

Tool holders

∅ 16 x 16

2440-0

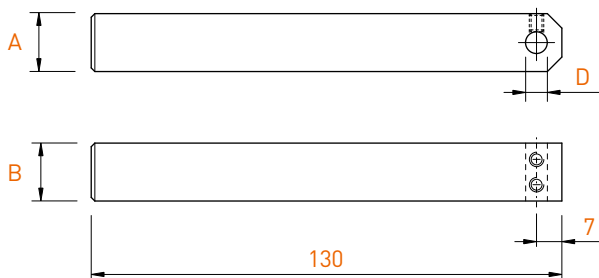

A x B	D	Art. N°
16 x 16	3.0	2440-0-3
16 x 16	4.0	2440-0-4
16 x 16	5.0	2440-0-5
16 x 16	6.0	2440-0-6



Porte-outils

Werkzeughalter

Tool holders

∅ 16 x 16

2440-8 / 2440-12

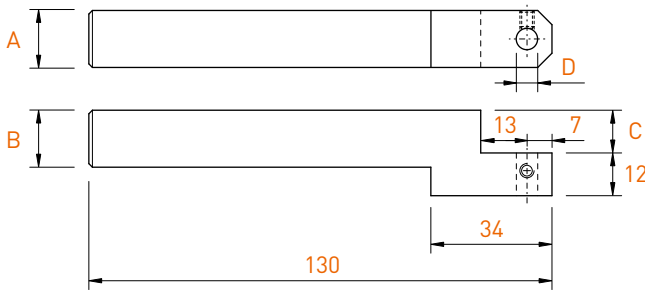

A x B	C	D	Art. N°
16 x 16	8	3.0	2440-8-3
16 x 16	8	4.0	2440-8-4
16 x 16	8	5.0	2440-8-5
16 x 16	8	6.0	2440-8-6
16 x 16	8	8.0	2440-8-8
16 x 16	12	3.0	2440-12-3
16 x 16	12	4.0	2440-12-4
16 x 16	12	5.0	2440-12-5
16 x 16	12	6.0	2440-12-6
16 x 16	12	8.0	2440-12-8

Porte-outils

Werkzeughalter

Tool holders

∅ 16 x 16

2440-18 / 2440-26

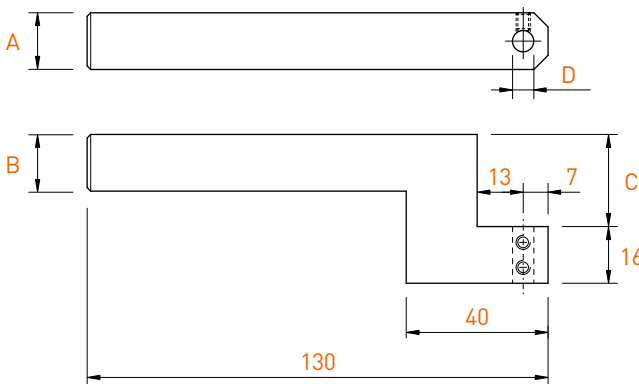

A x B	C	D	Art. N°
16 x 16	18	4.0	2440-18-4
16 x 16	18	5.0	2440-18-5
16 x 16	18	6.0	2440-18-6
16 x 16	18	8.0	2440-18-8
16 x 16	26	4.0	2440-26-4
16 x 16	26	5.0	2440-26-5
16 x 16	26	6.0	2440-26-6
16 x 16	26	8.0	2440-26-8

# TOOLING-Line

Porte-outils pour machines Tornos DECO 7/10

Werkzeughalter für Tornos DECO 7/10 Maschinen

Tool holders for Tornos DECO 7/10 machines

2435 / 2435-T

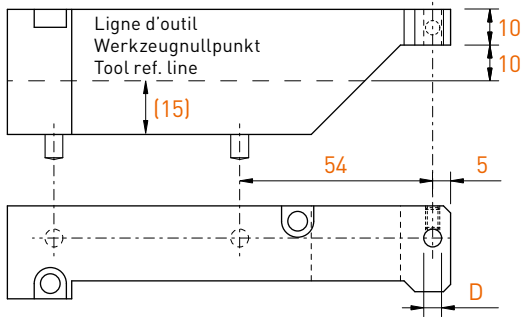

D	Art. N°
3.0	2435-3
4.0	2435-4
5.0	2435-5
6.0	2435-6

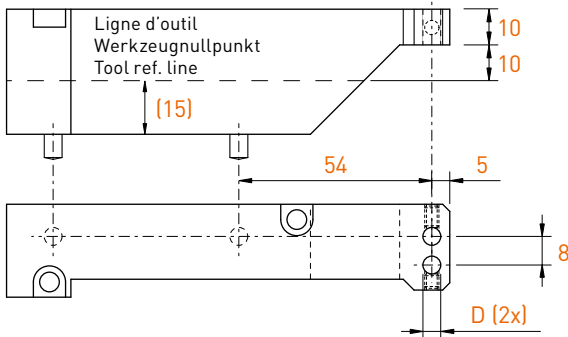

D (2x)	Art. N°
3.0	2435-3-T
4.0	2435-4-T
5.0	2435-5-T
6.0	2435-6-T

Porte-outils pour machines Tornos DECO 13 / EvoDECO 16

Werkzeughalter für Tornos DECO 13 / EvoDECO 16 Maschinen

Tool holders for Tornos DECO 13 / EvoDECO 16 machines

## 2436 / 2436-T

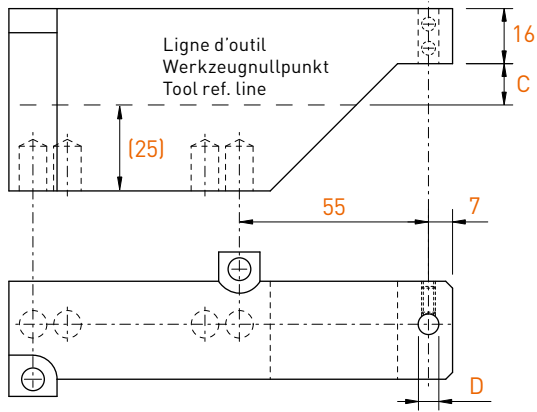

C	D	Art. N°
12	3.0	2436-12-3
12	4.0	2436-12-4
12	5.0	2436-12-5
12	6.0	2436-12-6
12	8.0	2436-12-8
18	3.0	2436-18-3
18	4.0	2436-18-4
18	5.0	2436-18-5
18	6.0	2436-18-6
18	8.0	2436-18-8

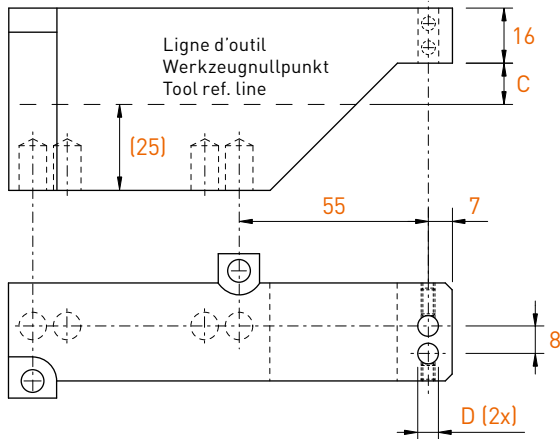

C	D (2x)	Art. N°
12	3.0	2436T-12-3
12	4.0	2436T-12-4
12	5.0	2436T-12-5
12	6.0	2436T-12-6
18	3.0	2436T-18-3
18	4.0	2436T-18-4
18	5.0	2436T-18-5
18	6.0	2436T-18-6

Entretoise

Erhöhungplatte

Spacer

## 2436-S12

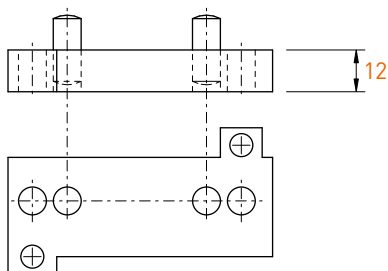

Art. N°

2436-S12

# TOOLING-Line

Forets à centrer plats

Zentrierflachbohrer

Centering flat drills

90°

1200 / 2200

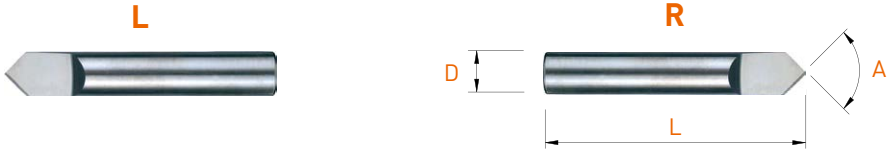

MD VHM HM			L	R
A	D	L	Art. N°	Art. N°
90°	3	17	1200-317	2200-317
90°	3	38	1200-338	2200-338
90°	4	40	1200-440	2200-440
90°	5	50	1200-550	2200-550
90°	6	50	1200-650	2200-650
90°	8	58	1200-858	2200-858
90°	10	66	1200-1066	2200-1066
90°	12	73	1200-1273	2200-1273

Forets à centrer hélicoïdaux

Zentrierspiralbohrer

Centering twist drills

90°

1500 / 2520

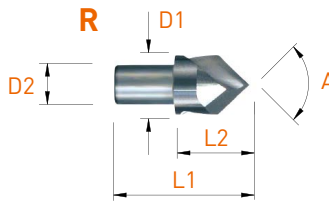

					HSS		MD / VHM / HM	
					L	R	L	R
A	D1	D2	L1	L2	Art. N°	Art. N°	Art. N°	Art. N°
90°	5	4	17	8	1500-5-HSS	2520-5-HSS	1500-5	2520-5
90°	7	5	17	8	1500-7-HSS	2520-7-HSS	1500-7	2520-7
90°	10	6	22	10	1500-10-HSS	2520-10-HSS	1500-10	2520-10
90°	12	8	26	12	1500-12-HSS	2520-12-HSS	1500-12	2520-12

Forets à centrer hélicoïdaux

Zentrierspiralbohrer

Centering twist drills

120°

1510 / 2530

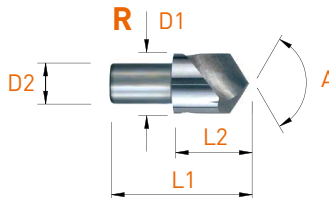

					MD VHM HM		L	R
A	D1	D2	L1	L2	Art. N°	Art. N°		
120°	5	4	17	8	1510-5	2530-5		
120°	7	5	17	8	1510-7	2530-7		
120°	10	6	22	10	1510-10	2530-10		
120°	12	8	26	12	1510-12	2530-12		

# TOOLING-Line

Burins intérieurs en métal dur

Vollhartmetall Innendrehwerkzeuge

Solid carbide internal turning tools

1600 / 2620

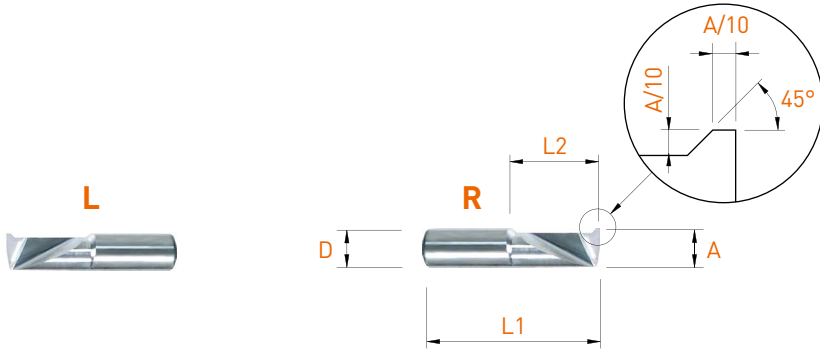

				L	R
MD VHM HM				Art. N°	Art. N°
A -0.05	D	L1	L2	Art. N°	Art. N°
2	3	13	4	1600-2-4	2620-2-4
3	3	15	6	1600-3-6	2620-3-6
4	4	17	8	1600-4-8	2620-4-8
4	4	21	12	1600-4-12	2620-4-12
5	5	21	10	1600-5-10	2620-5-10
5	5	26	15	1600-5-15	2620-5-15
6	6	25	12	1600-6-12	2620-6-12
6	6	31	18	1600-6-18	2620-6-18
8	8	32	16	1600-8-16	2620-8-16
8	8	40	24	1600-8-24	2620-8-24

Burins intérieurs en métal dur

Vollhartmetall Innendrehwerkzeuge

Solid carbide internal turning tools

1610 / 2630

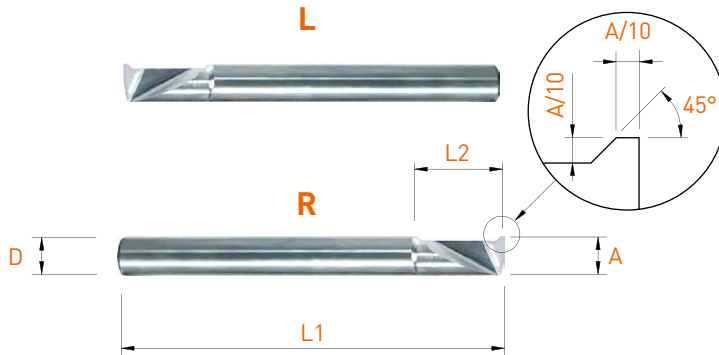

MD VHM HM				L	R
A -0.05	D	L1	L2	Art. N°	Art. N°
2	3	38	4	1610-2-4	2630-2-4
3	3	38	6	1610-3-6	2630-3-6
4	4	40	8	1610-4-8	2630-4-8
4	4	40	12	1610-4-12	2630-4-12
5	5	50	10	1610-5-10	2630-5-10
5	5	54	15	1610-5-15	2630-5-15
6	6	50	12	1610-6-12	2630-6-12
6	6	57	18	1610-6-18	2630-6-18
8	8	58	16	1610-8-16	2630-8-16
8	8	63	24	1610-8-24	2630-8-24
10	10	72	30	-	2630-10-30
12	12	83	36	-	2630-12-36

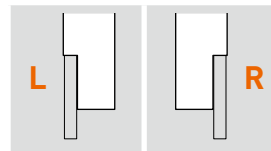
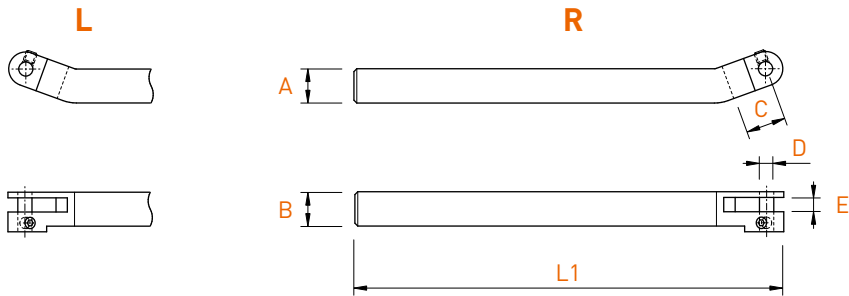

A x B	L	E	D	C	Art. N°	Art. N°
6 x 6	132	2	3	10	1402-623	2402-623
6 x 6	132	3	3	10	1402-633	2402-633
7 x 7	140	2	3	10	1402-723	2402-723
7 x 7	140	3	3	10	1402-733	2402-733
7 x 7	140	4	3	10	1402-743	2402-743
7 x 7	140	2	4	10	1402-724	2402-724
7 x 7	140	3	4	10	1402-734	2402-734
7 x 7	140	4	4	10	1402-744	2402-744
8 x 8	140	2	3	10	1402-823	2402-823
8 x 8	140	3	3	10	1402-833	2402-833
8 x 8	140	4	3	10	1402-843	2402-843
8 x 8	140	2	4	10	1402-824	2402-824
8 x 8	140	3	4	10	1402-834	2402-834
8 x 8	140	4	4	10	1402-844	2402-844
10 x 10	150	3	3	10	1402-1033	2402-1033
10 x 10	150	4	3	10	1402-1043	2402-1043
10 x 10	150	3	4	10	1402-1034	2402-1034
10 x 10	150	4	4	10	1402-1044	2402-1044
10 x 10	150	5	4	10	1402-1054	-
12 x 12	150	4	4	12	1402-1244	2402-1244
12 x 12	150	5	4	12	1402-1254	2402-1254
12 x 12	150	4	5	12	1402-1245	2402-1245
12 x 12	150	5	5	12	1402-1255	2402-1255
16 x 16	150	4	4	12	1402-1644	2402-1644
16 x 16	150	4	5	12	-	2402-1645
16 x 16	150	5	5	12	-	2402-1655
16 x 16	150	6	4	12	-	2402-1664
16 x 16	150	6	6	12	-	2402-1666
16 x 16	150	8	6	12	-	2402-1686



**Molettes en métal dur**

**Vollhartmetall Rändelrädchen**

**Solid carbide knurling wheels**

**1107**

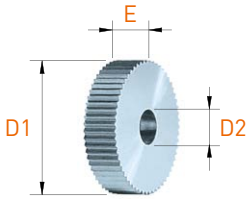

**AA**

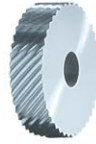

**BL**

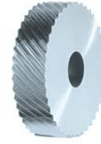

**BR**



**GE**

Molettes standards Standard Rändelrädchen Standard knurls	D1	E	D2	Pas (tous les 0.1 mm) Teilung (alle 0.1 mm) Pitch (every 0.1 mm)	
AA (0°)	8	2	3	0.2 - 0.6	
	8	2	4	0.2 - 0.6	
	8	3	3	0.2 - 0.6	
	8	3	4	0.2 - 0.6	
	8	4	3	0.2 - 0.6	
	8	4	4	0.2 - 0.6	
	10	2	3	0.2 - 0.8	
	10	2	4	0.2 - 0.8	
	10	3	3	0.2 - 0.8	
	BL 15° / BR 15° BL 30° / BR 30° BL 45° / BR 45°	10	3	4	0.2 - 0.8
		10	4	3	0.2 - 0.8
		10	4	4	0.2 - 0.8
		10	4	4	0.2 - 0.8
	GE 30° GE 45°	12	4	4	0.3 - 1.0
		15	4	4	0.4 - 1.0
		15	4	5	0.4 - 1.0
		15	5	4	0.4 - 1.0
		15	5	5	0.4 - 1.0
20		4	5	0.5 - 1.2	
20		5	5	0.5 - 1.2	
20		6	6	0.5 - 1.2	
20	8	6	0.5 - 1.2		





Molettes "Quick" "Quick"-Rändelrädchen "Quick"-knurling wheels	D1	E	D2	Pas (tous les 0.1 mm) Teilung (alle 0.1 mm) Pitch (every 0.1 mm)
AA (0°)	8.9	2.5	4	0.2 - 0.8
BL 15° / BR 15°	14.5	3	5	0.4 - 1.0
BL 30° / BR 30°	21.5	5	8	0.5 - 1.2

Exécutions spéciales sur demande  
Sonderausführungen auf Anfrage  
Special executions on request

MICRO-Line

APPLITEC



Micro-fraises Micropräzisionsfräser Micro end mills	Paramètres de coupe indicatifs Empfohlene Schnittwerte Standard machining data	> <b>8.02</b>
Micro-fraises Micropräzisionsfräser Micro end mills		> <b>8.03</b>
Micro-forets / Centreurs NC Microbohrer / NC-Zentrierbohrer Micro drills / NC centering drills	Paramètres de coupe indicatifs Empfohlene Schnittwerte Standard machining data	> <b>8.10</b>
Centreurs NC NC-Zentrierbohrer NC centering drills		> <b>8.11</b>
Micro-forets Microbohrer Micro drills		> <b>8.13</b>
Fraises à graver Gravierfräser Engraving mills	Paramètres de coupe indicatifs Empfohlene Schnittwerte Standard machining data	> <b>8.26</b>
Fraises à graver Gravierfräser Engraving mills		> <b>8.26</b>
Fraises en bout de finition Schlicht Schafffräser Finishing end mills	Paramètres de coupe indicatifs Empfohlene Schnittwerte Standard machining data	> <b>8.28</b>
Fraises en bout de finition Schlicht Schafffräser Finishing end mills		> <b>8.29</b>

# MICRO-Line

Micro-fraises



Micropräzisionsfräser

Micro end mills

Paramètres de coupe indicatifs

Empfohlene Schnittwerte

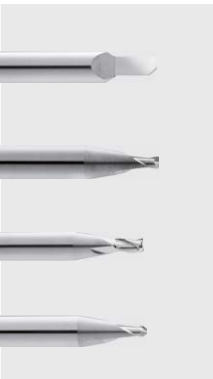
Standard machining data

		Z	L2	Spiral	Type	page			
		Z = 1	2 x D1	0°	3170-2	8.03	NEW		
					3170R-2	8.03	NEW		
		Z = 2				30°	0.75 x D1	8.04	NEW
							1.5 x D1	8.04	
							3 x D1	8.05	
							5 x D1	8.05	
							8 x D1	8.06	NEW
		Z = 3				30°	1.3 x D1	8.06	
							2 x D1	8.07	NEW
							3 x D1	8.07	
Z = 2				30°	0.75 x D1	8.08	NEW		
					1.5 x D1	8.08			
					3 x D1	8.09			

Matière Werkstoff Material	VC (m/min)	fz [mm/z]	
		Ø 0.2 - 1.2	Ø 1.3 - 2.9
Acier Stahl Steel < 700 N/mm <sup>2</sup>	30 - 90	0.002 - 0.010	0.005 - 0.018
Acier Stahl Steel > 700 N/mm <sup>2</sup>	25 - 60	0.001 - 0.007	0.002 - 0.012
Acier inoxydable Rostfreistahl Stainless steel	30 - 70	0.001 - 0.008	0.004 - 0.020
Titane Titan Titanium	25 - 40	0.001 - 0.008	0.003 - 0.010
Aluminium	80 - 250	0.002 - 0.010	0.005 - 0.020
Cuivre Kupfer Copper	60 - 120	0.001 - 0.080	0.004 - 0.020
Laiton Messing Brass	80 - 180	0.002 - 0.012	0.006 - 0.025
Or Gold Gold	80 - 160	0.002 - 0.012	0.006 - 0.025

Micro-fraises

Micropräzisionsfräser

Micro end mills

## 3170 / 3170R

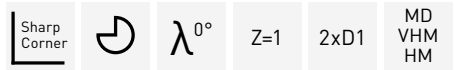
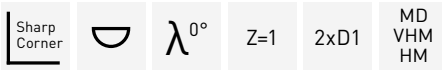

D1 +0.005 / -0.010	L2	D2 h6	L1	Art. N°
0.20	0.4	3.00	39	<b>3170-2-0.20</b>
0.30	0.6	3.00	39	<b>3170-2-0.30</b>
0.40	0.8	3.00	39	<b>3170-2-0.40</b>
0.50	1.0	3.00	39	<b>3170-2-0.50</b>
0.60	1.2	3.00	39	<b>3170-2-0.60</b>
0.70	1.4	3.00	39	<b>3170-2-0.70</b>
0.80	1.6	3.00	39	<b>3170-2-0.80</b>
0.90	1.8	3.00	39	<b>3170-2-0.90</b>
1.00	2.0	3.00	39	<b>3170-2-1.00</b>
1.10	2.2	3.00	39	<b>3170-2-1.10</b>
1.20	2.4	3.00	39	<b>3170-2-1.20</b>
1.30	2.6	3.00	39	<b>3170-2-1.30</b>
1.40	2.8	3.00	39	<b>3170-2-1.40</b>
1.50	3.0	3.00	39	<b>3170-2-1.50</b>
1.60	3.2	3.00	39	<b>3170-2-1.60</b>
1.70	3.4	3.00	39	<b>3170-2-1.70</b>
1.80	3.6	3.00	39	<b>3170-2-1.80</b>
1.90	3.8	3.00	39	<b>3170-2-1.90</b>
2.00	4.0	3.00	39	<b>3170-2-2.00</b>
2.50	5.0	3.00	39	<b>3170-2-2.50</b>
3.00	6.0	4.00	40	<b>3170-2-3.00</b>

D1 +0.005 / -0.010	L2	D2 h6	L1	Art. N°
0.20	0.4	3.00	39	<b>3170R-2-0.20</b>
0.30	0.6	3.00	39	<b>3170R-2-0.30</b>
0.40	0.8	3.00	39	<b>3170R-2-0.40</b>
0.50	1.0	3.00	39	<b>3170R-2-0.50</b>
0.60	1.2	3.00	39	<b>3170R-2-0.60</b>
0.70	1.4	3.00	39	<b>3170R-2-0.70</b>
0.80	1.6	3.00	39	<b>3170R-2-0.80</b>
0.90	1.8	3.00	39	<b>3170R-2-0.90</b>
1.00	2.0	3.00	39	<b>3170R-2-1.00</b>
1.10	2.2	3.00	39	<b>3170R-2-1.10</b>
1.20	2.4	3.00	39	<b>3170R-2-1.20</b>
1.30	2.6	3.00	39	<b>3170R-2-1.30</b>
1.40	2.8	3.00	39	<b>3170R-2-1.40</b>
1.50	3.0	3.00	39	<b>3170R-2-1.50</b>
1.60	3.2	3.00	39	<b>3170R-2-1.60</b>
1.70	3.4	3.00	39	<b>3170R-2-1.70</b>
1.80	3.6	3.00	39	<b>3170R-2-1.80</b>
1.90	3.8	3.00	39	<b>3170R-2-1.90</b>
2.00	4.0	3.00	39	<b>3170R-2-2.00</b>
2.10	4.1	3.00	39	<b>3170R-2-2.10</b>
2.20	4.4	3.00	39	<b>3170R-2-2.20</b>
2.30	4.6	3.00	39	<b>3170R-2-2.30</b>
2.40	4.8	3.00	39	<b>3170R-2-2.40</b>
2.50	5.0	3.00	39	<b>3170R-2-2.50</b>
2.60	5.2	3.00	39	<b>3170R-2-2.60</b>
2.70	5.4	3.00	39	<b>3170R-2-2.70</b>
2.80	5.6	3.00	39	<b>3170R-2-2.80</b>
2.90	5.8	3.00	39	<b>3170R-2-2.90</b>
3.00	6.0	4.00	40	<b>3170R-2-3.00</b>

# MICRO-Line

Micro-fraises

Micropräzisionsfräser

Micro end mills

3271-0.75 / 3271-1.5

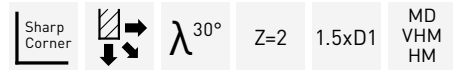
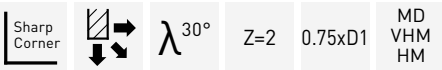

D1 +0.005 / -0.010	L2	D2 h6	L1	Art. N°
0.20	0.15	3.00	39	3271-0.75-0.20
0.30	0.25	3.00	39	3271-0.75-0.30
0.40	0.3	3.00	39	3271-0.75-0.40
0.50	0.37	3.00	39	3271-0.75-0.50
0.60	0.45	3.00	39	3271-0.75-0.60
0.70	0.53	3.00	39	3271-0.75-0.70
0.80	0.6	3.00	39	3271-0.75-0.80
0.90	0.7	3.00	39	3271-0.75-0.90
1.00	0.75	3.00	39	3271-0.75-1.00
1.10	0.9	3.00	39	3271-0.75-1.10
1.20	0.9	3.00	39	3271-0.75-1.20
1.30	1.0	3.00	39	3271-0.75-1.30
1.40	1.1	3.00	39	3271-0.75-1.40
1.50	1.15	3.00	39	3271-0.75-1.50
1.60	1.2	3.00	39	3271-0.75-1.60
1.70	1.3	3.00	39	3271-0.75-1.70
1.80	1.4	3.00	39	3271-0.75-1.80
1.90	1.45	3.00	39	3271-0.75-1.90
2.00	1.5	3.00	39	3271-0.75-2.00

D1 +0.005 / -0.010	L2	D2 h6	L1	Art. N°
0.10	0.15	3.00	39	3271-1.5-0.10
0.15	0.2	3.00	39	3271-1.5-0.15
0.20	0.3	3.00	39	3271-1.5-0.20
0.25	0.35	3.00	39	3271-1.5-0.25
0.30	0.45	3.00	39	3271-1.5-0.30
0.40	0.6	3.00	39	3271-1.5-0.40
0.50	0.75	3.00	39	3271-1.5-0.50
0.60	0.9	3.00	39	3271-1.5-0.60
0.70	1.05	3.00	39	3271-1.5-0.70
0.80	1.2	3.00	39	3271-1.5-0.80
0.90	1.35	3.00	39	3271-1.5-0.90
1.00	1.5	3.00	39	3271-1.5-1.00
1.10	1.65	3.00	39	3271-1.5-1.10
1.20	1.8	3.00	39	3271-1.5-1.20
1.30	1.95	3.00	39	3271-1.5-1.30
1.40	2.1	3.00	39	3271-1.5-1.40
1.50	2.25	3.00	39	3271-1.5-1.50
1.60	2.4	3.00	39	3271-1.5-1.60
1.70	2.55	3.00	39	3271-1.5-1.70
1.80	2.7	3.00	39	3271-1.5-1.80
1.90	2.85	3.00	39	3271-1.5-1.90
2.00	3.0	3.00	39	3271-1.5-2.00

Micro-fraises

Micropräzisionsfräser

Micro end mills

## 3271-3 / 3271-5

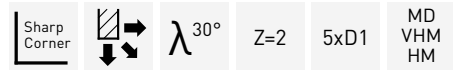
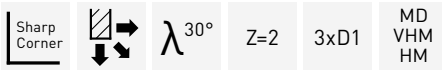

D1 +0.005 / -0.010	L2	D2 h6	L1	Art. N°
0.10	0.25	3.00	39	3271-3-0.10
0.15	0.3	3.00	39	3271-3-0.15
0.20	0.5	3.00	39	3271-3-0.20
0.25	0.5	3.00	39	3271-3-0.25
0.30	1.0	3.00	39	3271-3-0.30
0.40	1.2	3.00	39	3271-3-0.40
0.50	1.5	3.00	39	3271-3-0.50
0.60	2.0	3.00	39	3271-3-0.60
0.70	2.0	3.00	39	3271-3-0.70
0.75	2.0	3.00	39	3271-3-0.75
0.80	2.5	3.00	39	3271-3-0.80
0.90	2.5	3.00	39	3271-3-0.90
1.00	3.0	3.00	39	3271-3-1.00
1.10	3.0	3.00	39	3271-3-1.10
1.20	4.0	3.00	39	3271-3-1.20
1.30	4.0	3.00	39	3271-3-1.30
1.40	4.0	3.00	39	3271-3-1.40
1.50	4.5	3.00	39	3271-3-1.50
1.60	4.5	3.00	39	3271-3-1.60
1.70	5.0	3.00	39	3271-3-1.70
1.80	6.0	3.00	39	3271-3-1.80
1.90	6.0	3.00	39	3271-3-1.90
2.00	6.0	3.00	39	3271-3-2.00
2.10	6.0	3.00	39	3271-3-2.10
2.20	6.5	3.00	39	3271-3-2.20
2.30	7.0	3.00	39	3271-3-2.30
2.40	7.0	3.00	39	3271-3-2.40
2.50	7.5	3.00	39	3271-3-2.50
2.60	7.5	3.00	39	3271-3-2.60
2.70	8.0	3.00	39	3271-3-2.70
2.80	8.0	3.00	39	3271-3-2.80
2.90	8.0	3.00	39	3271-3-2.90

D1 +0.005 / -0.010	L2	D2 h6	L1	Art. N°
0.30	1.5	3.00	39	3271-5-0.30
0.40	2.0	3.00	39	3271-5-0.40
0.50	2.5	3.00	39	3271-5-0.50
0.60	3.0	3.00	39	3271-5-0.60
0.70	3.5	3.00	39	3271-5-0.70
0.80	4.0	3.00	39	3271-5-0.80
0.90	4.5	3.00	39	3271-5-0.90
1.00	5.0	3.00	39	3271-5-1.00
1.10	5.5	3.00	39	3271-5-1.10
1.20	6.0	3.00	39	3271-5-1.20
1.50	7.5	3.00	39	3271-5-1.50
2.00	10.0	3.00	39	3271-5-2.00
2.50	12.5	3.00	39	3271-5-2.50

# MICRO-Line

Micro-fraises

Micropräzisionsfräser

Micro end mills

3271-8 / 3371-1.3

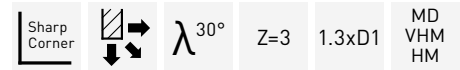
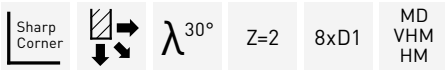

D1 +0.005 / -0.010	L2	D2 h6	L1	Art. N°
0.40	3.2	3.00	39	<b>3271-8-0.40</b>
0.50	4.0	3.00	39	<b>3271-8-0.50</b>
0.60	5.0	3.00	39	<b>3271-8-0.60</b>
0.70	5.6	3.00	39	<b>3271-8-0.70</b>
0.80	6.0	3.00	39	<b>3271-8-0.80</b>
0.90	7.2	3.00	39	<b>3271-8-0.90</b>
1.00	8.0	3.00	39	<b>3271-8-1.00</b>
1.20	9.0	3.00	39	<b>3271-8-1.20</b>
1.50	12.0	4.00	50	<b>3271-8-1.50</b>
2.00	16.0	4.00	50	<b>3271-8-2.00</b>
2.50	20.0	4.00	50	<b>3271-8-2.50</b>

D1 +0.005 / -0.010	L2	D2 h6	L1	Art. N°
0.30	0.4	3.00	39	<b>3371-1.3-0.30</b>
0.40	0.5	3.00	39	<b>3371-1.3-0.40</b>
0.45	0.6	3.00	39	<b>3371-1.3-0.45</b>
0.50	0.7	3.00	39	<b>3371-1.3-0.50</b>
0.60	0.8	3.00	39	<b>3371-1.3-0.60</b>
0.70	0.9	3.00	39	<b>3371-1.3-0.70</b>
0.80	1.0	3.00	39	<b>3371-1.3-0.80</b>
0.90	1.3	3.00	39	<b>3371-1.3-0.90</b>
1.00	1.3	3.00	39	<b>3371-1.3-1.00</b>
1.10	1.5	3.00	39	<b>3371-1.3-1.10</b>
1.20	1.6	3.00	39	<b>3371-1.3-1.20</b>
1.30	1.8	3.00	39	<b>3371-1.3-1.30</b>
1.40	1.8	3.00	39	<b>3371-1.3-1.40</b>
1.50	2.0	3.00	39	<b>3371-1.3-1.50</b>
1.60	2.0	3.00	39	<b>3371-1.3-1.60</b>
1.70	2.0	3.00	39	<b>3371-1.3-1.70</b>
1.80	2.4	3.00	39	<b>3371-1.3-1.80</b>
1.90	2.4	3.00	39	<b>3371-1.3-1.90</b>
2.00	2.6	3.00	39	<b>3371-1.3-2.00</b>
2.20	3.0	3.00	39	<b>3371-1.3-2.20</b>
2.50	3.3	3.00	39	<b>3371-1.3-2.50</b>
2.80	3.5	3.00	39	<b>3371-1.3-2.80</b>
2.90	3.5	3.00	39	<b>3371-1.3-2.90</b>



Micro-fraises

Micropräzisionsfräser

Micro end mills

## 3371-2 / 3371-3

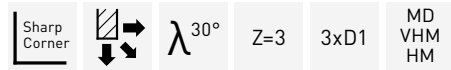
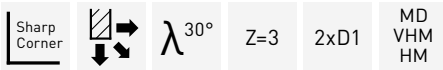
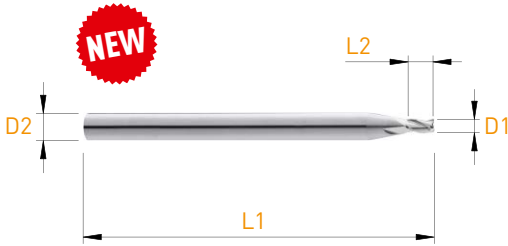

D1 +0.005 / -0.010	L2	D2 h <sub>6</sub>	L1	Art. N°
0.30	0.6	3.00	39	<b>3371-2-0.30</b>
0.40	0.8	3.00	39	<b>3371-2-0.40</b>
0.50	1.0	3.00	39	<b>3371-2-0.50</b>
0.60	1.2	3.00	39	<b>3371-2-0.60</b>
0.70	1.4	3.00	39	<b>3371-2-0.70</b>
0.75	1.5	3.00	39	<b>3371-2-0.75</b>
0.80	1.6	3.00	39	<b>3371-2-0.80</b>
0.90	1.8	3.00	39	<b>3371-2-0.90</b>
1.00	2.0	3.00	39	<b>3371-2-1.00</b>
1.10	2.2	3.00	39	<b>3371-2-1.10</b>
1.20	2.4	3.00	39	<b>3371-2-1.20</b>
1.30	2.6	3.00	39	<b>3371-2-1.30</b>
1.40	2.8	3.00	39	<b>3371-2-1.40</b>
1.50	3.0	3.00	39	<b>3371-2-1.50</b>
1.60	3.2	3.00	39	<b>3371-2-1.60</b>
1.70	3.4	3.00	39	<b>3371-2-1.70</b>
1.80	3.6	3.00	39	<b>3371-2-1.80</b>
1.90	3.8	3.00	39	<b>3371-2-1.90</b>
2.00	4.0	3.00	39	<b>3371-2-2.00</b>
2.10	4.2	3.00	39	<b>3371-2-2.10</b>
2.20	4.4	3.00	39	<b>3371-2-2.20</b>
2.30	4.6	3.00	39	<b>3371-2-2.30</b>
2.40	4.8	3.00	39	<b>3371-2-2.40</b>
2.50	5.0	3.00	39	<b>3371-2-2.50</b>
2.60	5.2	3.00	39	<b>3371-2-2.60</b>
2.70	5.4	3.00	39	<b>3371-2-2.70</b>
2.80	5.6	3.00	39	<b>3371-2-2.80</b>
2.90	5.8	3.00	39	<b>3371-2-2.90</b>

D1 +0.005 / -0.010	L2	D2 h <sub>6</sub>	L1	Art. N°
0.30	0.9	3.00	39	<b>3371-3-0.30</b>
0.40	1.2	3.00	39	<b>3371-3-0.40</b>
0.50	1.5	3.00	39	<b>3371-3-0.50</b>
0.60	2.0	3.00	39	<b>3371-3-0.60</b>
0.70	2.0	3.00	39	<b>3371-3-0.70</b>
0.75	2.0	3.00	39	<b>3371-3-0.75</b>
0.80	2.5	3.00	39	<b>3371-3-0.80</b>
0.90	2.5	3.00	39	<b>3371-3-0.90</b>
1.00	3.0	3.00	39	<b>3371-3-1.00</b>
1.10	3.3	3.00	39	<b>3371-3-1.10</b>
1.20	4.0	3.00	39	<b>3371-3-1.20</b>
1.30	4.0	3.00	39	<b>3371-3-1.30</b>
1.40	4.0	3.00	39	<b>3371-3-1.40</b>
1.50	4.5	3.00	39	<b>3371-3-1.50</b>
1.60	4.5	3.00	39	<b>3371-3-1.60</b>
1.70	5.0	3.00	39	<b>3371-3-1.70</b>
1.80	6.0	3.00	39	<b>3371-3-1.80</b>
1.90	6.0	3.00	39	<b>3371-3-1.90</b>
2.00	6.0	3.00	39	<b>3371-3-2.00</b>
2.10	6.0	3.00	39	<b>3371-3-2.10</b>
2.20	6.5	3.00	39	<b>3371-3-2.20</b>
2.30	7.0	3.00	39	<b>3371-3-2.30</b>
2.40	7.0	3.00	39	<b>3371-3-2.40</b>
2.50	7.5	3.00	39	<b>3371-3-2.50</b>
2.60	7.5	3.00	39	<b>3371-3-2.60</b>
2.70	8.0	3.00	39	<b>3371-3-2.70</b>
2.80	8.0	3.00	39	<b>3371-3-2.80</b>
2.90	8.5	3.00	39	<b>3371-3-2.90</b>

# MICRO-Line

Micro-fraises

Micropräzisionsfräser

Micro end mills

3278-0.75 / 3278-1.5

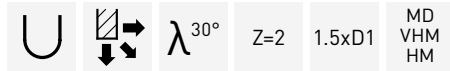
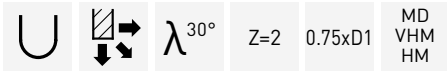

D1 +0.005 / -0.010	R	L2	D2 h <sub>6</sub>	L1	Art. N°
0.20	0.10	0.15	3.00	39	<b>3278-0.75-0.20</b>
0.30	0.15	0.20	3.00	39	<b>3278-0.75-0.30</b>
0.40	0.20	0.30	3.00	39	<b>3278-0.75-0.40</b>
0.50	0.25	0.37	3.00	39	<b>3278-0.75-0.50</b>
0.60	0.30	0.45	3.00	39	<b>3278-0.75-0.60</b>
0.80	0.40	0.60	3.00	39	<b>3278-0.75-0.80</b>
1.00	0.50	0.75	3.00	39	<b>3278-0.75-1.00</b>

D1 +0.005 / -0.010	R	L2	D2 h <sub>6</sub>	L1	Art. N°
0.20	0.10	0.3	3.00	39	<b>3278-1.5-0.20</b>
0.25	0.125	0.35	3.00	39	<b>3278-1.5-0.25</b>
0.30	0.15	0.45	3.00	39	<b>3278-1.5-0.30</b>
0.40	0.20	0.6	3.00	39	<b>3278-1.5-0.40</b>
0.50	0.25	0.75	3.00	39	<b>3278-1.5-0.50</b>
0.60	0.30	0.9	3.00	39	<b>3278-1.5-0.60</b>
0.70	0.35	1.05	3.00	39	<b>3278-1.5-0.70</b>
0.80	0.40	1.2	3.00	39	<b>3278-1.5-0.80</b>
0.90	0.45	1.35	3.00	39	<b>3278-1.5-0.90</b>
1.00	0.50	1.5	3.00	39	<b>3278-1.5-1.00</b>
1.10	0.55	1.65	3.00	39	<b>3278-1.5-1.10</b>
1.20	0.60	1.8	3.00	39	<b>3278-1.5-1.20</b>
1.30	0.65	1.95	3.00	39	<b>3278-1.5-1.30</b>
1.40	0.70	2.1	3.00	39	<b>3278-1.5-1.40</b>
1.50	0.75	2.25	3.00	39	<b>3278-1.5-1.50</b>
1.60	0.80	2.4	3.00	39	<b>3278-1.5-1.60</b>
1.80	0.90	2.7	3.00	39	<b>3278-1.5-1.80</b>
2.00	1.00	3.0	3.00	39	<b>3278-1.5-2.00</b>

Micro-fraises

Micropräzisionsfräser

Micro end mills

3278-3

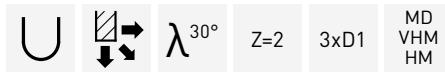







D1 +0.005 / -0.010	R	L2	D2 h <sub>6</sub>	L1	Art. N°
0.20	0.10	0.6	3.00	39	3278-3-0.20
0.30	0.15	1.0	3.00	39	3278-3-0.30
0.40	0.20	1.0	3.00	39	3278-3-0.40
0.50	0.25	1.5	3.00	39	3278-3-0.50
0.60	0.30	1.5	3.00	39	3278-3-0.60
0.70	0.35	2.0	3.00	39	3278-3-0.70
0.80	0.40	2.0	3.00	39	3278-3-0.80
0.90	0.45	2.5	3.00	39	3278-3-0.90
1.00	0.50	3.0	3.00	39	3278-3-1.00
1.20	0.60	4.0	3.00	39	3278-3-1.20
1.40	0.70	4.0	3.00	39	3278-3-1.40
1.50	0.75	4.0	3.00	39	3278-3-1.50
1.60	0.80	4.0	3.00	39	3278-3-1.60
1.80	0.90	5.5	3.00	39	3278-3-1.80
2.00	1.00	6.0	3.00	39	3278-3-2.00
2.10	1.05	6.0	3.00	39	3278-3-2.10
2.20	1.10	6.0	3.00	39	3278-3-2.20
2.50	1.25	7.5	3.00	39	3278-3-2.50
2.80	1.40	8.4	3.00	39	3278-3-2.80

# MICRO-Line

**Micro-forets / Centreurs NC**  
**Microbohrer / NC-Zentrierbohrer**  
**Micro drills / NC centering drills**

**Paramètres de coupe indicatifs**  
**Empfohlene Schnittwerte**  
**Standard machining data**

	Spiral	L2	Type	page
	25°	-	1680-90 / 2680-90	8.11
	25°	-	1680-120 / 2680-120	8.12
			1010 / 2010	8.13
	35°	-	2011	8.14
	24°	-	2012	8.14
	35°	-	2013	8.15
	30°	-	2014	8.15
	30°	2 x D1	2020	8.16
	35°	6 x D1	2023	8.18
	25°	12 x D1	2026	8.21
	35°	5 x D1	2030 (Z=3)	8.23

**NEW**  
**NEW**  
**NEW**  
**NEW**

Matière Werkstoff Material	VC (m/min)	fz [mm/z]			
		Ø 0.4 - 0.6	Ø 0.6 - 1.0	Ø 1.0 - 3.0	Ø 3.0 - 6.0
Acier Stahl Steel < 700 N/mm <sup>2</sup>	60 - 100	0.004 - 0.008	0.006 - 0.015	0.010 - 0.040	0.040 - 0.100
Acier Stahl Steel > 700 N/mm <sup>2</sup>	30 - 60	0.003 - 0.005	0.005 - 0.012	0.010 - 0.040	0.040 - 0.080
Acier inoxydable Rostfreistahl Stainless steel	30 - 60	0.003 - 0.006	0.005 - 0.012	0.010 - 0.040	0.040 - 0.080
Titane Titan Titanium	25 - 50	0.002 - 0.005	0.004 - 0.010	0.008 - 0.030	0.030 - 0.070
Aluminium	60 - 150	0.004 - 0.010	0.006 - 0.030	0.020 - 0.070	0.050 - 0.150
Cuivre Kupfer Copper	50 - 80	0.004 - 0.012	0.007 - 0.020	0.050 - 0.060	0.050 - 0.120
Laiton Messing Brass	60 - 100	0.005 - 0.015	0.008 - 0.030	0.020 - 0.070	0.060 - 0.150
Or Gold Gold	50 - 100	0.004 - 0.010	0.006 - 0.030	0.020 - 0.070	0.060 - 0.150

Centreurs NC

NC-Zentrierbohrer

NC centering drills

1680-90° / 2680-90°

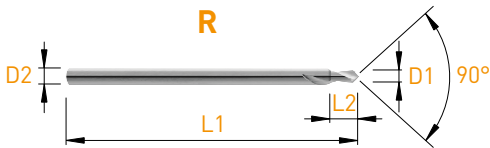

MD VHM HM				R
D1 h6	L2	D2 h6	L1	Art. N°
0.50	1.5	2.00	39	2680-0.5-90
1.00	3.0	2.00	39	2680-1.0-90
1.50	4.0	2.00	39	2680-1.5-90

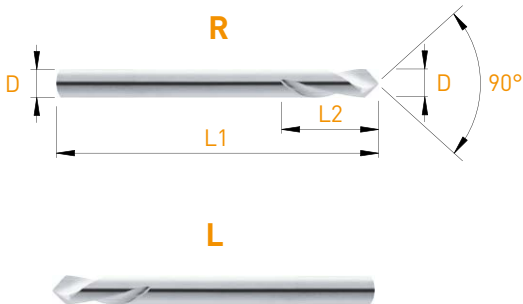

MD VHM HM			L	R
D h6	L2	L1	Art. N°	Art. N°
2.0	8	38	1680-2-90	2680-2-90
2.5	8	38	1680-2.5-90	2680-2.5-90
3.0	10	38	1680-3-90	2680-3-90
4.0	12	50	1680-4-90	2680-4-90
5.0	15	50	1680-5-90	2680-5-90
6.0	16	57	1680-6-90	2680-6-90
8.0	20	63	1680-8-90	2680-8-90
10.0	22	72	1680-10-90	2680-10-90
12.0	24	73	1680-12-90	2680-12-90
16.0	26	82	1680-16-90	2680-16-90
20.0	30	92	-	2680-20-90

HSS			R
D h6	L2	L1	Art. N°
3.0	10	38	2680-3-90-HSS
4.0	12	50	2680-4-90-HSS
5.0	15	50	2680-5-90-HSS
6.0	16	57	2680-6-90-HSS
8.0	20	63	2680-8-90-HSS
10.0	22	72	2680-10-90-HSS
12.0	24	73	2680-12-90-HSS

# MICRO-Line

Centreurs NC

NC-Zentrierbohrer

NC centering drills

1680-120° / 2680-120°

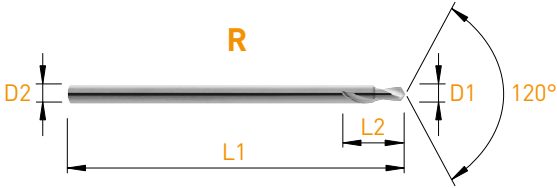

MD VHM HM				R	
	D1 h <sub>6</sub>	L2	D2 h <sub>6</sub>	L1	Art. N°
	0.50	1.5	2.00	39	<b>2680-0.5-120</b>
	1.00	3.0	2.00	39	<b>2680-1.0-120</b>
	1.50	4.0	2.00	39	<b>2680-1.5-120</b>

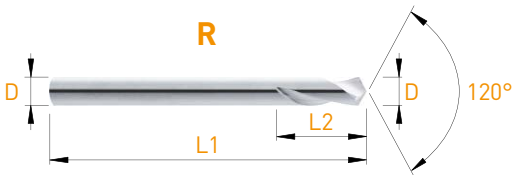

MD VHM HM			L	R	
	D h <sub>6</sub>	L2	L1	Art. N°	Art. N°
	2.0	8	38	<b>1680-2-120</b>	<b>2680-2-120</b>
	2.5	8	38	<b>1680-2.5-120</b>	<b>2680-2.5-120</b>
	3.0	10	38	<b>1680-3-120</b>	<b>2680-3-120</b>
	4.0	12	50	<b>1680-4-120</b>	<b>2680-4-120</b>
	5.0	15	50	<b>1680-5-120</b>	<b>2680-5-120</b>
	6.0	16	57	<b>1680-6-120</b>	<b>2680-6-120</b>
	8.0	20	63	<b>1680-8-120</b>	<b>2680-8-120</b>
	10.0	22	72	<b>1680-10-120</b>	<b>2680-10-120</b>
	12.0	24	73	<b>1680-12-120</b>	<b>2680-12-120</b>
	16.0	26	82	-	<b>2680-16-120</b>
	20.0	30	92	-	<b>2680-20-120</b>



Forets cylindriques

Zylindrische Bohrer

Cylindrical drills

1010 / 2010

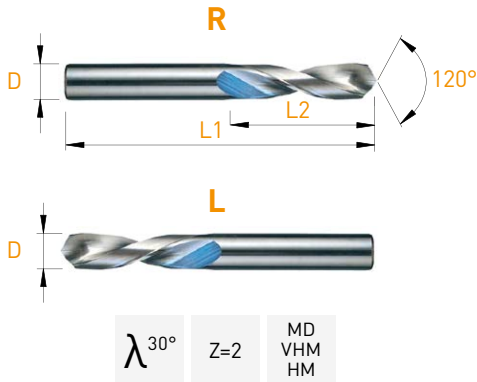

D h <sub>6</sub>	L1	L2	L	R
			Art. N°	Art. N°
0.50	30	5	1010-0.50	2010-0.50
0.55	30	5	1010-0.55	2010-0.55
0.60	30	5	1010-0.60	2010-0.60
0.65	30	6	1010-0.65	2010-0.65
0.70	30	6	1010-0.70	2010-0.70
0.75	30	8	1010-0.75	2010-0.75
0.80	30	8	1010-0.80	2010-0.80
0.85	30	9	1010-0.85	2010-0.85
0.90	30	9	1010-0.90	2010-0.90
0.95	30	10	1010-0.95	2010-0.95
1.00	30	10	1010-1.00	2010-1.00
1.05	30	10	1010-1.05	2010-1.05
1.10	30	10	1010-1.10	2010-1.10
1.15	30	12	1010-1.15	2010-1.15
1.20	30	12	1010-1.20	2010-1.20
1.25	30	12	1010-1.25	2010-1.25
1.30	30	12	1010-1.30	2010-1.30
1.35	30	12	1010-1.35	2010-1.35
1.40	30	12	1010-1.40	2010-1.40
1.45	30	12	1010-1.45	2010-1.45
1.50	30	12	1010-1.50	2010-1.50
1.55	40	16	1010-1.55	2010-1.55
1.60	40	16	1010-1.60	2010-1.60
1.65	40	16	1010-1.65	2010-1.65
1.70	40	16	1010-1.70	2010-1.70
1.75	40	16	1010-1.75	2010-1.75
1.80	40	16	1010-1.80	2010-1.80
1.85	40	16	1010-1.85	2010-1.85
1.90	40	16	1010-1.90	2010-1.90
1.95	40	16	1010-1.95	2010-1.95
2.00	40	16	1010-2.00	2010-2.00
2.05	40	18	1010-2.05	2010-2.05
2.10	40	18	1010-2.10	2010-2.10

D h <sub>6</sub>	L1	L2	L	R
			Art. N°	Art. N°
2.15	40	18	1010-2.15	2010-2.15
2.20	40	18	1010-2.20	2010-2.20
2.25	40	18	1010-2.25	2010-2.25
2.30	40	18	1010-2.30	2010-2.30
2.35	40	18	1010-2.35	2010-2.35
2.40	40	18	1010-2.40	2010-2.40
2.45	40	18	1010-2.45	2010-2.45
2.50	40	18	1010-2.50	2010-2.50
2.55	45	18	1010-2.55	2010-2.55
2.60	45	18	1010-2.60	2010-2.60
2.65	45	18	1010-2.65	2010-2.65
2.70	45	18	1010-2.70	2010-2.70
2.75	45	18	1010-2.75	2010-2.75
2.80	45	18	1010-2.80	2010-2.80
2.85	45	18	1010-2.85	2010-2.85
2.90	45	18	1010-2.90	2010-2.90
2.95	45	18	1010-2.95	2010-2.95
3.00	45	18	1010-3.00	2010-3.00
3.10	45	20	1010-3.10	2010-3.10
3.20	50	20	1010-3.20	2010-3.20
3.30	50	20	1010-3.30	2010-3.30
3.40	50	20	1010-3.40	2010-3.40
3.50	50	20	1010-3.50	2010-3.50
3.60	50	20	1010-3.60	2010-3.60
3.70	50	20	1010-3.70	2010-3.70
3.80	50	20	1010-3.80	2010-3.80
3.90	50	20	1010-3.90	2010-3.90
4.00	50	20	1010-4.00	2010-4.00
4.10	50	25	1010-4.10	2010-4.10
4.20	50	25	1010-4.20	2010-4.20
4.30	50	25	1010-4.30	2010-4.30
4.40	50	25	1010-4.40	2010-4.40
4.50	50	25	1010-4.50	2010-4.50
4.60	50	25	1010-4.60	2010-4.60
4.70	50	25	1010-4.70	2010-4.70
4.80	50	25	1010-4.80	2010-4.80
4.90	50	25	1010-4.90	2010-4.90
5.00	50	25	1010-5.00	2010-5.00
5.10	50	25	1010-5.10	2010-5.10
5.20	50	25	1010-5.20	2010-5.20
5.30	50	25	1010-5.30	2010-5.30
5.40	50	25	1010-5.40	2010-5.40
5.50	50	25	1010-5.50	2010-5.50
5.60	50	25	1010-5.60	2010-5.60
5.70	50	25	1010-5.70	2010-5.70
5.80	50	25	1010-5.80	2010-5.80
5.90	50	25	1010-5.90	2010-5.90
6.00	50	25	1010-6.00	2010-6.00

# MICRO-Line

Micro-forets

Microbohrer

Micro drills

2011 / 2012

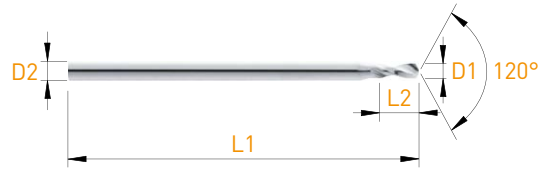

$\lambda^{35^\circ}$

Z=2

MD  
VHM  
HM

$\lambda^{24^\circ}$

Z=2

MD  
VHM  
HM

D1 h6	L2	D2 h6	L1	Art. N°
0.80	2.0	2.00	30	<b>2011-0.80</b>
0.90	2.0	2.00	30	<b>2011-0.90</b>
1.00	2.0	2.00	30	<b>2011-1.00</b>
1.10	2.0	2.00	30	<b>2011-1.10</b>
1.20	2.5	2.00	30	<b>2011-1.20</b>
1.30	2.5	2.00	30	<b>2011-1.30</b>
1.40	2.5	2.00	30	<b>2011-1.40</b>
1.50	4.0	2.00	30	<b>2011-1.50</b>
2.00	5.0	2.00	30	<b>2011-2.00</b>

D1 h6	L2	D2 h6	L1	Art. N°
0.50	1.7	1.50	30	<b>2012-0.50</b>
0.55	1.9	1.50	30	<b>2012-0.55</b>
0.60	1.9	1.50	30	<b>2012-0.60</b>
0.65	1.9	1.50	30	<b>2012-0.65</b>
0.70	2.4	1.50	30	<b>2012-0.70</b>
0.75	2.4	1.50	30	<b>2012-0.75</b>
0.80	2.6	1.50	30	<b>2012-0.80</b>
0.85	2.6	1.50	30	<b>2012-0.85</b>
0.90	3.0	1.50	30	<b>2012-0.90</b>
0.95	3.0	1.50	30	<b>2012-0.95</b>
1.00	3.4	1.50	30	<b>2012-1.00</b>
1.10	3.8	1.50	30	<b>2012-1.10</b>
1.20	4.2	1.50	30	<b>2012-1.20</b>
1.30	4.2	1.50	30	<b>2012-1.30</b>
1.40	4.7	1.50	30	<b>2012-1.40</b>
1.50	4.7	2.00	38	<b>2012-1.50</b>
1.60	5.4	2.00	38	<b>2012-1.60</b>
1.70	5.4	2.00	38	<b>2012-1.70</b>
1.80	6.5	2.00	38	<b>2012-1.80</b>
1.90	6.5	2.00	38	<b>2012-1.90</b>
2.00	6.5	2.50	38	<b>2012-2.00</b>
2.10	6.5	2.50	38	<b>2012-2.10</b>
2.20	6.5	2.50	38	<b>2012-2.20</b>
2.30	6.5	2.50	38	<b>2012-2.30</b>
2.40	6.5	2.50	38	<b>2012-2.40</b>



Micro-forets

Microbohrer

Micro drills

2013 / 2014

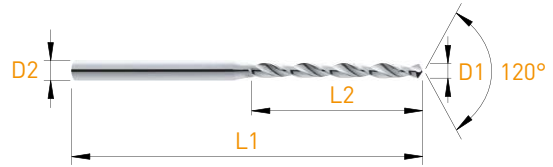
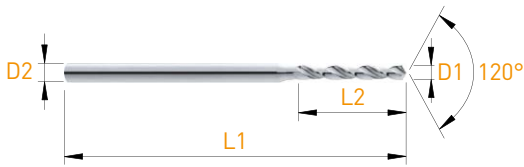

$\lambda$  35°

Z=2

MD  
VHM  
HM

$\lambda$  30°

Z=2

MD  
VHM  
HM

D1 h6	L2	D2 h6	L1	Art. N°
0.40	3.6	1.00	25	<b>2013-0.40</b>
0.45	3.6	1.00	25	<b>2013-0.45</b>
0.50	4.0	1.00	25	<b>2013-0.50</b>
0.55	4.5	1.00	25	<b>2013-0.55</b>
0.60	4.5	1.00	25	<b>2013-0.60</b>
0.65	5.0	1.00	25	<b>2013-0.65</b>
0.70	5.6	1.00	25	<b>2013-0.70</b>
0.75	5.6	1.00	25	<b>2013-0.75</b>
0.80	6.3	1.50	30	<b>2013-0.80</b>
0.85	6.3	1.50	30	<b>2013-0.85</b>
0.90	7.1	1.50	30	<b>2013-0.90</b>
0.95	7.1	1.50	30	<b>2013-0.95</b>
1.00	8.0	1.50	30	<b>2013-1.00</b>
1.05	8.0	1.50	30	<b>2013-1.05</b>
1.10	9.0	1.50	30	<b>2013-1.10</b>
1.15	9.0	1.50	30	<b>2013-1.15</b>
1.20	10.0	1.50	30	<b>2013-1.20</b>
1.25	10.0	1.50	30	<b>2013-1.25</b>
1.30	10.0	1.50	30	<b>2013-1.30</b>
1.35	11.2	1.50	30	<b>2013-1.35</b>
1.40	11.2	1.50	30	<b>2013-1.40</b>
1.45	11.2	1.50	30	<b>2013-1.45</b>
1.50	12.0	2.00	38	<b>2013-1.50</b>
1.60	12.0	2.00	38	<b>2013-1.60</b>
1.70	12.0	2.00	38	<b>2013-1.70</b>
1.80	12.0	2.00	38	<b>2013-1.80</b>
1.90	12.0	2.00	38	<b>2013-1.90</b>

D1 h6	L2	D2 h6	L1	Art. N°
0.50	6.0	1.50	30	<b>2014-0.50</b>
0.55	6.5	1.50	30	<b>2014-0.55</b>
0.60	6.5	1.50	30	<b>2014-0.60</b>
0.65	7.5	1.50	30	<b>2014-0.65</b>
0.70	8.5	1.50	30	<b>2014-0.70</b>
0.75	8.5	1.50	30	<b>2014-0.75</b>
0.80	9.5	1.50	30	<b>2014-0.80</b>
0.85	9.5	1.50	30	<b>2014-0.85</b>
0.90	10.5	1.50	30	<b>2014-0.90</b>
0.95	10.5	1.50	30	<b>2014-0.95</b>
1.00	12.0	1.50	38	<b>2014-1.00</b>
1.05	12.0	1.50	38	<b>2014-1.05</b>
1.10	13.5	1.50	38	<b>2014-1.10</b>
1.15	13.5	1.50	38	<b>2014-1.15</b>
1.20	15.0	1.50	38	<b>2014-1.20</b>
1.25	15.0	1.50	38	<b>2014-1.25</b>
1.30	17.0	1.50	38	<b>2014-1.30</b>
1.35	17.0	1.50	38	<b>2014-1.35</b>
1.40	17.0	1.50	38	<b>2014-1.40</b>
1.45	17.0	1.50	38	<b>2014-1.45</b>
1.50	18.0	2.00	38	<b>2014-1.50</b>
1.55	18.0	2.00	38	<b>2014-1.55</b>
1.60	18.0	2.00	38	<b>2014-1.60</b>
1.65	18.0	2.00	38	<b>2014-1.65</b>
1.70	18.0	2.00	38	<b>2014-1.70</b>
1.75	18.0	2.00	38	<b>2014-1.75</b>
1.80	18.0	2.00	38	<b>2014-1.80</b>
1.85	18.0	2.00	38	<b>2014-1.85</b>
1.90	18.0	2.00	38	<b>2014-1.90</b>
1.95	18.0	2.00	38	<b>2014-1.95</b>

# MICRO-Line

Micro-forets

Microbohrer

Micro drills

Ø 0.10 - Ø 0.99 mm

2020

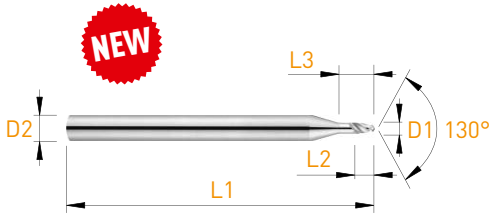

$\lambda$  30°

Z=2

2xD1

MD  
VHM  
HM

D1 0/+0.005	L2	L3	L1	D2 h <sub>6</sub>	Art. N°
0.10	0.35	0.55	38	3.00	2020-0.10
0.11	0.35	0.55	38	3.00	2020-0.11
0.12	0.35	0.55	38	3.00	2020-0.12
0.13	0.40	0.60	38	3.00	2020-0.13
0.14	0.40	0.60	38	3.00	2020-0.14
0.15	0.40	0.60	38	3.00	2020-0.15
0.16	0.40	0.60	38	3.00	2020-0.16
0.17	0.50	0.70	38	3.00	2020-0.17
0.18	0.50	0.70	38	3.00	2020-0.18
0.19	0.50	0.70	38	3.00	2020-0.19
0.20	0.55	0.75	38	3.00	2020-0.20
0.21	0.55	0.75	38	3.00	2020-0.21
0.22	0.60	0.80	38	3.00	2020-0.22
0.23	0.60	0.80	38	3.00	2020-0.23
0.24	0.60	0.80	38	3.00	2020-0.24
0.25	0.70	0.90	38	3.00	2020-0.25
0.26	0.70	0.90	38	3.00	2020-0.26
0.27	0.70	0.90	38	3.00	2020-0.27
0.28	0.80	1.00	38	3.00	2020-0.28
0.29	0.80	1.00	38	3.00	2020-0.29
0.30	0.90	1.20	38	3.00	2020-0.30
0.31	0.90	1.20	38	3.00	2020-0.31
0.32	0.90	1.20	38	3.00	2020-0.32
0.33	0.90	1.20	38	3.00	2020-0.33
0.34	0.90	1.35	38	3.00	2020-0.34
0.35	0.90	1.35	38	3.00	2020-0.35
0.36	0.95	1.35	38	3.00	2020-0.36
0.37	0.95	1.35	38	3.00	2020-0.37
0.38	0.95	1.50	38	3.00	2020-0.38
0.39	0.95	1.50	38	3.00	2020-0.39
0.40	0.80	1.60	38	3.00	2020-0.40
0.41	0.82	1.60	38	3.00	2020-0.41
0.42	0.84	1.60	38	3.00	2020-0.42
0.43	0.86	1.60	38	3.00	2020-0.43
0.44	0.88	1.60	38	3.00	2020-0.44
0.45	0.90	1.60	38	3.00	2020-0.45
0.46	0.92	1.70	38	3.00	2020-0.46
0.47	0.94	1.70	38	3.00	2020-0.47
0.48	0.96	1.70	38	3.00	2020-0.48

D1 0/+0.005	L2	L3	L1	D2 h <sub>6</sub>	Art. N°
0.49	0.98	1.70	38	3.00	2020-0.49
0.50	1.00	1.70	38	3.00	2020-0.50
0.51	1.02	1.80	38	3.00	2020-0.51
0.52	1.04	1.80	38	3.00	2020-0.52
0.53	1.06	1.80	38	3.00	2020-0.53
0.54	1.08	1.80	38	3.00	2020-0.54
0.55	1.10	1.80	38	3.00	2020-0.55
0.56	1.12	1.90	38	3.00	2020-0.56
0.57	1.14	1.90	38	3.00	2020-0.57
0.58	1.16	1.90	38	3.00	2020-0.58
0.59	1.18	1.90	38	3.00	2020-0.59
0.60	1.20	1.90	38	3.00	2020-0.60
0.61	1.22	2.00	38	3.00	2020-0.61
0.62	1.24	2.00	38	3.00	2020-0.62
0.63	1.26	2.00	38	3.00	2020-0.63
0.64	1.28	2.00	38	3.00	2020-0.64
0.65	1.30	2.00	38	3.00	2020-0.65
0.66	1.32	2.10	38	3.00	2020-0.66
0.67	1.34	2.10	38	3.00	2020-0.67
0.68	1.36	2.10	38	3.00	2020-0.68
0.69	1.38	2.10	38	3.00	2020-0.69
0.70	1.40	2.10	38	3.00	2020-0.70
0.71	1.42	2.20	38	3.00	2020-0.71
0.72	1.44	2.20	38	3.00	2020-0.72
0.73	1.46	2.20	38	3.00	2020-0.73
0.74	1.48	2.20	38	3.00	2020-0.74
0.75	1.50	2.20	38	3.00	2020-0.75
0.76	1.52	2.30	38	3.00	2020-0.76
0.77	1.54	2.30	38	3.00	2020-0.77
0.78	1.56	2.30	38	3.00	2020-0.78
0.79	1.58	2.30	38	3.00	2020-0.79
0.80	1.60	2.30	38	3.00	2020-0.80
0.81	1.62	2.40	38	3.00	2020-0.81
0.82	1.64	2.40	38	3.00	2020-0.82
0.83	1.66	2.40	38	3.00	2020-0.83
0.84	1.68	2.40	38	3.00	2020-0.84
0.85	1.70	2.40	38	3.00	2020-0.85
0.86	1.72	2.50	38	3.00	2020-0.86
0.87	1.74	2.50	38	3.00	2020-0.87
0.88	1.76	2.50	38	3.00	2020-0.88
0.89	1.78	2.50	38	3.00	2020-0.89
0.90	1.80	2.50	38	3.00	2020-0.90
0.91	1.82	2.60	38	3.00	2020-0.91
0.92	1.84	2.60	38	3.00	2020-0.92
0.93	1.86	2.60	38	3.00	2020-0.93
0.94	1.88	2.60	38	3.00	2020-0.94
0.95	1.90	2.60	38	3.00	2020-0.95
0.96	1.92	2.70	38	3.00	2020-0.96
0.97	1.94	2.70	38	3.00	2020-0.97
0.98	1.96	2.70	38	3.00	2020-0.98
0.99	1.98	2.70	38	3.00	2020-0.99

Micro-forets

Microbohrer

Micro drills

Ø 1.00 - Ø 2.00 mm

2020

D1 0/+0.005	L2	L3	L1	D2 h6	Art. N°
1.00	2.00	2.70	38	3.00	2020-1.00
1.01	2.02	3.50	38	3.00	2020-1.01
1.02	2.04	3.50	38	3.00	2020-1.02
1.03	2.06	3.50	38	3.00	2020-1.03
1.04	2.08	3.50	38	3.00	2020-1.04
1.05	2.10	3.50	38	3.00	2020-1.05
1.06	2.12	3.60	38	3.00	2020-1.06
1.07	2.14	3.60	38	3.00	2020-1.07
1.08	2.16	3.60	38	3.00	2020-1.08
1.09	2.18	3.60	38	3.00	2020-1.09
1.10	2.20	3.60	38	3.00	2020-1.10
1.11	2.22	3.70	38	3.00	2020-1.11
1.12	2.24	3.70	38	3.00	2020-1.12
1.13	2.26	3.70	38	3.00	2020-1.13
1.14	2.28	3.70	38	3.00	2020-1.14
1.15	2.30	3.70	38	3.00	2020-1.15
1.16	2.32	3.80	38	3.00	2020-1.16
1.17	2.34	3.80	38	3.00	2020-1.17
1.18	2.36	3.80	38	3.00	2020-1.18
1.19	2.38	3.80	38	3.00	2020-1.19
1.20	2.40	3.80	38	3.00	2020-1.20
1.21	2.42	4.20	38	3.00	2020-1.21
1.22	2.44	4.20	38	3.00	2020-1.22
1.23	2.46	4.20	38	3.00	2020-1.23
1.24	2.48	4.20	38	3.00	2020-1.24
1.25	2.50	4.20	38	3.00	2020-1.25
1.26	2.52	4.30	38	3.00	2020-1.26
1.27	2.54	4.30	38	3.00	2020-1.27
1.28	2.56	4.30	38	3.00	2020-1.28
1.29	2.58	4.30	38	3.00	2020-1.29
1.30	2.60	4.30	38	3.00	2020-1.30
1.31	2.62	4.40	38	3.00	2020-1.31
1.32	2.64	4.40	38	3.00	2020-1.32
1.33	2.66	4.40	38	3.00	2020-1.33
1.34	2.68	4.40	38	3.00	2020-1.34
1.35	2.70	4.40	38	3.00	2020-1.35
1.36	2.72	4.50	38	3.00	2020-1.36
1.37	2.74	4.50	38	3.00	2020-1.37
1.38	2.76	4.50	38	3.00	2020-1.38
1.39	2.78	4.50	38	3.00	2020-1.39
1.40	2.80	4.50	38	3.00	2020-1.40
1.41	2.82	4.60	38	3.00	2020-1.41
1.42	2.84	4.60	38	3.00	2020-1.42
1.43	2.86	4.60	38	3.00	2020-1.43
1.44	2.88	4.60	38	3.00	2020-1.44
1.45	2.90	4.60	38	3.00	2020-1.45
1.46	2.92	4.70	38	3.00	2020-1.46
1.47	2.94	4.70	38	3.00	2020-1.47
1.48	2.96	4.70	38	3.00	2020-1.48
1.49	2.98	4.70	38	3.00	2020-1.49
1.50	3.00	4.70	38	3.00	2020-1.50

D1 0/+0.005	L2	L3	L1	D2 h6	Art. N°
1.51	3.02	5.10	38	3.00	2020-1.51
1.52	3.04	5.10	38	3.00	2020-1.52
1.53	3.06	5.10	38	3.00	2020-1.53
1.54	3.08	5.10	38	3.00	2020-1.54
1.55	3.10	5.10	38	3.00	2020-1.55
1.56	3.12	5.20	38	3.00	2020-1.56
1.57	3.14	5.20	38	3.00	2020-1.57
1.58	3.16	5.20	38	3.00	2020-1.58
1.59	3.18	5.20	38	3.00	2020-1.59
1.60	3.20	5.20	38	3.00	2020-1.60
1.61	3.22	5.30	38	3.00	2020-1.61
1.62	3.24	5.30	38	3.00	2020-1.62
1.63	3.26	5.30	38	3.00	2020-1.63
1.64	3.28	5.30	38	3.00	2020-1.64
1.65	3.30	5.30	38	3.00	2020-1.65
1.66	3.32	5.40	38	3.00	2020-1.66
1.67	3.34	5.40	38	3.00	2020-1.67
1.68	3.36	5.40	38	3.00	2020-1.68
1.69	3.38	5.40	38	3.00	2020-1.69
1.70	3.40	5.40	38	3.00	2020-1.70
1.71	3.42	5.50	38	3.00	2020-1.71
1.72	3.44	5.50	38	3.00	2020-1.72
1.73	3.46	5.50	38	3.00	2020-1.73
1.74	3.48	5.50	38	3.00	2020-1.74
1.75	3.50	5.50	38	3.00	2020-1.75
1.76	3.52	5.60	38	3.00	2020-1.76
1.77	3.54	5.60	38	3.00	2020-1.77
1.78	3.56	5.60	38	3.00	2020-1.78
1.79	3.58	5.60	38	3.00	2020-1.79
1.80	3.60	5.60	38	3.00	2020-1.80
1.81	3.62	5.70	38	3.00	2020-1.81
1.82	3.64	5.70	38	3.00	2020-1.82
1.83	3.66	5.70	38	3.00	2020-1.83
1.84	3.68	5.70	38	3.00	2020-1.84
1.85	3.70	5.70	38	3.00	2020-1.85
1.86	3.72	5.80	38	3.00	2020-1.86
1.87	3.74	5.80	38	3.00	2020-1.87
1.88	3.76	5.80	38	3.00	2020-1.88
1.89	3.78	5.80	38	3.00	2020-1.89
1.90	3.80	5.80	38	3.00	2020-1.90
1.91	3.82	5.90	38	3.00	2020-1.91
1.92	3.84	5.90	38	3.00	2020-1.92
1.93	3.86	5.90	38	3.00	2020-1.93
1.94	3.88	5.90	38	3.00	2020-1.94
1.95	3.90	5.90	38	3.00	2020-1.95
1.96	3.92	6.00	38	3.00	2020-1.96
1.97	3.94	6.00	38	3.00	2020-1.97
1.98	3.96	6.00	38	3.00	2020-1.98
1.99	3.98	6.00	38	3.00	2020-1.99
2.00	4.00	6.00	38	3.00	2020-2.00

# MICRO-Line

Micro-forets

Microbohrer

Micro drills

Ø 0.10 - Ø 0.99 mm

2023

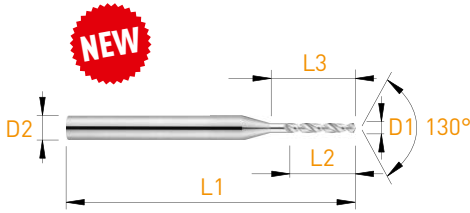

$\lambda$  35°

Z=2

6xD1

MD  
VHM  
HM

D1 0/-0.004	L2	L3	L1	D2 h6	Art. N°
0.10	0.50	0.70	38	3.00	2023-0.10
0.11	0.50	0.70	38	3.00	2023-0.11
0.12	0.50	0.70	38	3.00	2023-0.12
0.13	0.80	1.00	38	3.00	2023-0.13
0.14	0.80	1.00	38	3.00	2023-0.14
0.15	0.80	1.00	38	3.00	2023-0.15
0.16	1.10	1.40	38	3.00	2023-0.16
0.17	1.10	1.40	38	3.00	2023-0.17
0.18	1.10	1.40	38	3.00	2023-0.18
0.19	1.10	1.40	38	3.00	2023-0.19
0.20	1.50	1.80	38	3.00	2023-0.20
0.21	1.50	1.80	38	3.00	2023-0.21
0.22	1.50	1.80	38	3.00	2023-0.22
0.23	1.50	1.80	38	3.00	2023-0.23
0.24	1.50	1.80	38	3.00	2023-0.24
0.25	1.90	2.20	38	3.00	2023-0.25
0.26	1.90	2.20	38	3.00	2023-0.26
0.27	1.90	2.20	38	3.00	2023-0.27
0.28	1.90	2.20	38	3.00	2023-0.28
0.29	1.90	2.20	38	3.00	2023-0.29
0.30	1.80	2.40	38	3.00	2023-0.30
0.31	1.80	2.40	38	3.00	2023-0.31
0.32	1.80	2.40	38	3.00	2023-0.32
0.33	1.80	2.40	38	3.00	2023-0.33
0.34	1.80	2.40	38	3.00	2023-0.34
0.35	2.20	2.80	38	3.00	2023-0.35
0.36	2.20	2.80	38	3.00	2023-0.36
0.37	2.20	2.80	38	3.00	2023-0.37
0.38	2.20	2.80	38	3.00	2023-0.38
0.39	2.70	3.60	38	3.00	2023-0.39
0.40	2.70	3.60	38	3.00	2023-0.40
0.41	2.70	3.60	38	3.00	2023-0.41
0.42	2.70	3.60	38	3.00	2023-0.42
0.43	2.70	3.60	38	3.00	2023-0.43
0.44	2.70	3.60	38	3.00	2023-0.44
0.45	2.70	3.60	38	3.00	2023-0.45
0.46	2.70	3.60	38	3.00	2023-0.46
0.47	2.70	3.60	38	3.00	2023-0.47
0.48	2.70	3.60	38	3.00	2023-0.48

D1 0/-0.004	L2	L3	L1	D2 h6	Art. N°
0.49	3.20	4.00	38	3.00	2023-0.49
0.50	3.20	4.00	38	3.00	2023-0.50
0.51	3.20	4.00	38	3.00	2023-0.51
0.52	3.20	4.00	38	3.00	2023-0.52
0.53	3.20	4.00	38	3.00	2023-0.53
0.54	3.60	4.50	38	3.00	2023-0.54
0.55	3.60	4.50	38	3.00	2023-0.55
0.56	3.60	4.50	38	3.00	2023-0.56
0.57	3.60	4.50	38	3.00	2023-0.57
0.58	3.60	4.50	38	3.00	2023-0.58
0.59	3.60	4.50	38	3.00	2023-0.59
0.60	3.60	4.50	38	3.00	2023-0.60
0.61	3.90	5.00	38	3.00	2023-0.61
0.62	3.90	5.00	38	3.00	2023-0.62
0.63	3.90	5.00	38	3.00	2023-0.63
0.64	3.90	5.00	38	3.00	2023-0.64
0.65	3.90	5.00	38	3.00	2023-0.65
0.66	3.90	5.00	38	3.00	2023-0.66
0.67	3.90	5.00	38	3.00	2023-0.67
0.68	4.50	5.60	38	3.00	2023-0.68
0.69	4.50	5.60	38	3.00	2023-0.69
0.70	4.50	5.60	38	3.00	2023-0.70
0.71	4.50	5.60	38	3.00	2023-0.71
0.72	4.50	5.60	38	3.00	2023-0.72
0.73	4.50	5.60	38	3.00	2023-0.73
0.74	4.50	5.60	38	3.00	2023-0.74
0.75	4.50	5.60	38	3.00	2023-0.75
0.76	5.00	6.30	38	3.00	2023-0.76
0.77	5.00	6.30	38	3.00	2023-0.77
0.78	5.00	6.30	38	3.00	2023-0.78
0.79	5.00	6.30	38	3.00	2023-0.79
0.80	5.00	6.30	38	3.00	2023-0.80
0.81	5.00	6.30	38	3.00	2023-0.81
0.82	5.00	6.30	38	3.00	2023-0.82
0.83	5.00	6.30	38	3.00	2023-0.83
0.84	5.00	6.30	38	3.00	2023-0.84
0.85	5.00	6.30	38	3.00	2023-0.85
0.86	5.70	7.10	38	3.00	2023-0.86
0.87	5.70	7.10	38	3.00	2023-0.87
0.88	5.70	7.10	38	3.00	2023-0.88
0.89	5.70	7.10	38	3.00	2023-0.89
0.90	5.70	7.10	38	3.00	2023-0.90
0.91	5.70	7.10	38	3.00	2023-0.91
0.92	5.70	7.10	38	3.00	2023-0.92
0.93	5.70	7.10	38	3.00	2023-0.93
0.94	5.70	7.10	38	3.00	2023-0.94
0.95	5.70	7.10	38	3.00	2023-0.95
0.96	6.50	8.00	38	3.00	2023-0.96
0.97	6.50	8.00	38	3.00	2023-0.97
0.98	6.50	8.00	38	3.00	2023-0.98
0.99	6.50	8.00	38	3.00	2023-0.99

Micro-forets

Microbohrer

Micro drills

Ø 1.00 - Ø 2.00 mm

2023

D1 0/-0.004	L2	L3	L1	D2 h6	Art. N°
1.00	6.50	8.00	38	3.00	2023-1.00
1.01	6.50	8.00	38	3.00	2023-1.01
1.02	6.50	8.00	38	3.00	2023-1.02
1.03	6.50	8.00	38	3.00	2023-1.03
1.04	6.50	8.00	38	3.00	2023-1.04
1.05	6.50	8.00	38	3.00	2023-1.05
1.06	7.30	9.00	38	3.00	2023-1.06
1.07	7.30	9.00	38	3.00	2023-1.07
1.08	7.30	9.00	38	3.00	2023-1.08
1.09	7.30	9.00	38	3.00	2023-1.09
1.10	7.30	9.00	38	3.00	2023-1.10
1.11	7.30	9.00	38	3.00	2023-1.11
1.12	7.30	9.00	38	3.00	2023-1.12
1.13	7.30	9.00	38	3.00	2023-1.13
1.14	7.30	9.00	38	3.00	2023-1.14
1.15	7.30	9.00	38	3.00	2023-1.15
1.16	8.20	10.00	38	3.00	2023-1.16
1.17	8.20	10.00	38	3.00	2023-1.17
1.18	8.20	10.00	38	3.00	2023-1.18
1.19	8.20	10.00	38	3.00	2023-1.19
1.20	8.20	10.00	38	3.00	2023-1.20
1.21	8.20	10.00	38	3.00	2023-1.21
1.22	8.20	10.00	38	3.00	2023-1.22
1.23	8.20	10.00	38	3.00	2023-1.23
1.24	8.20	10.00	38	3.00	2023-1.24
1.25	8.20	10.00	38	3.00	2023-1.25
1.26	8.20	10.00	38	3.00	2023-1.26
1.27	8.20	10.00	38	3.00	2023-1.27
1.28	8.20	10.00	38	3.00	2023-1.28
1.29	8.20	10.00	38	3.00	2023-1.29
1.30	8.20	10.00	38	3.00	2023-1.30
1.31	9.20	11.20	38	3.00	2023-1.31
1.32	9.20	11.20	38	3.00	2023-1.32
1.33	9.20	11.20	38	3.00	2023-1.33
1.34	9.20	11.20	38	3.00	2023-1.34
1.35	9.20	11.20	38	3.00	2023-1.35
1.36	9.20	11.20	38	3.00	2023-1.36
1.37	9.20	11.20	38	3.00	2023-1.37
1.38	9.20	11.20	38	3.00	2023-1.38
1.39	9.20	11.20	38	3.00	2023-1.39
1.40	9.20	11.20	38	3.00	2023-1.40
1.41	9.20	11.20	38	3.00	2023-1.41
1.42	9.20	11.20	38	3.00	2023-1.42
1.43	9.20	11.20	38	3.00	2023-1.43
1.44	9.20	11.20	38	3.00	2023-1.44
1.45	9.20	11.20	38	3.00	2023-1.45
1.46	9.20	11.20	38	3.00	2023-1.46
1.47	9.20	11.20	38	3.00	2023-1.47
1.48	9.20	11.20	38	3.00	2023-1.48
1.49	9.20	11.20	38	3.00	2023-1.49
1.50	9.20	11.20	38	3.00	2023-1.50

D1 0/-0.004	L2	L3	L1	D2 h6	Art. N°
1.51	11.20	13.40	38	3.00	2023-1.51
1.52	11.20	13.40	38	3.00	2023-1.52
1.53	11.20	13.40	38	3.00	2023-1.53
1.54	11.20	13.40	38	3.00	2023-1.54
1.55	11.20	13.40	38	3.00	2023-1.55
1.56	11.20	13.40	38	3.00	2023-1.56
1.57	11.20	13.40	38	3.00	2023-1.57
1.58	11.20	13.40	38	3.00	2023-1.58
1.59	11.20	13.40	38	3.00	2023-1.59
1.60	11.20	13.40	38	3.00	2023-1.60
1.61	11.20	13.40	38	3.00	2023-1.61
1.62	11.20	13.40	38	3.00	2023-1.62
1.63	11.20	13.40	38	3.00	2023-1.63
1.64	11.20	13.40	38	3.00	2023-1.64
1.65	11.20	13.40	38	3.00	2023-1.65
1.66	11.20	13.40	38	3.00	2023-1.66
1.67	11.20	13.40	38	3.00	2023-1.67
1.68	11.20	13.40	38	3.00	2023-1.68
1.69	11.20	13.40	38	3.00	2023-1.69
1.70	11.20	13.40	38	3.00	2023-1.70
1.71	11.20	13.40	38	3.00	2023-1.71
1.72	11.20	13.40	38	3.00	2023-1.72
1.73	11.20	13.40	38	3.00	2023-1.73
1.74	11.20	13.40	38	3.00	2023-1.74
1.75	11.20	13.40	38	3.00	2023-1.75
1.76	11.20	13.40	38	3.00	2023-1.76
1.77	11.20	13.40	38	3.00	2023-1.77
1.78	11.20	13.40	38	3.00	2023-1.78
1.79	11.20	13.40	38	3.00	2023-1.79
1.80	11.20	13.40	38	3.00	2023-1.80
1.81	11.20	13.40	38	3.00	2023-1.81
1.82	11.20	13.40	38	3.00	2023-1.82
1.83	11.20	13.40	38	3.00	2023-1.83
1.84	11.20	13.40	38	3.00	2023-1.84
1.85	11.20	13.40	38	3.00	2023-1.85
1.86	11.20	13.40	38	3.00	2023-1.86
1.87	11.20	13.40	38	3.00	2023-1.87
1.88	11.20	13.40	38	3.00	2023-1.88
1.89	11.20	13.40	38	3.00	2023-1.89
1.90	11.20	13.40	38	3.00	2023-1.90
1.91	11.20	13.40	38	3.00	2023-1.91
1.92	11.20	13.40	38	3.00	2023-1.92
1.93	11.20	13.40	38	3.00	2023-1.93
1.94	11.20	13.40	38	3.00	2023-1.94
1.95	11.20	13.40	38	3.00	2023-1.95
1.96	11.20	13.40	38	3.00	2023-1.96
1.97	11.20	13.40	38	3.00	2023-1.97
1.98	11.20	13.40	38	3.00	2023-1.98
1.99	11.20	13.40	38	3.00	2023-1.99
2.00	11.20	13.40	38	3.00	2023-2.00

D1 0/-0.004	L2	L3	L1	D2 h6	Art. N°	D1 0/-0.004	L2	L3	L1	D2 h6	Art. N°
2.01	12.50	14.00	38	3.00	2023-2.01	2.51	14.00	17.00	38	3.00	2023-2.51
2.02	12.50	14.00	38	3.00	2023-2.02	2.52	14.00	17.00	38	3.00	2023-2.52
2.03	12.50	14.00	38	3.00	2023-2.03	2.53	14.00	17.00	38	3.00	2023-2.53
2.04	12.50	14.00	38	3.00	2023-2.04	2.54	14.00	17.00	38	3.00	2023-2.54
2.05	12.50	14.00	38	3.00	2023-2.05	2.55	14.00	17.00	38	3.00	2023-2.55
2.06	12.50	14.00	38	3.00	2023-2.06	2.56	14.00	17.00	38	3.00	2023-2.56
2.07	12.50	14.00	38	3.00	2023-2.07	2.57	14.00	17.00	38	3.00	2023-2.57
2.08	12.50	14.00	38	3.00	2023-2.08	2.58	14.00	17.00	38	3.00	2023-2.58
2.09	12.50	14.00	38	3.00	2023-2.09	2.59	14.00	17.00	38	3.00	2023-2.59
2.10	12.50	14.00	38	3.00	2023-2.10	2.60	14.00	17.00	38	3.00	2023-2.60
2.11	12.50	14.00	38	3.00	2023-2.11	2.61	14.00	17.00	38	3.00	2023-2.61
2.12	12.50	14.00	38	3.00	2023-2.12	2.62	14.00	17.00	38	3.00	2023-2.62
2.13	12.50	14.00	38	3.00	2023-2.13	2.63	14.00	17.00	38	3.00	2023-2.63
2.14	12.50	14.00	38	3.00	2023-2.14	2.64	14.00	17.00	38	3.00	2023-2.64
2.15	12.50	14.00	38	3.00	2023-2.15	2.65	14.00	17.00	38	3.00	2023-2.65
2.16	12.50	14.00	38	3.00	2023-2.16	2.66	14.00	17.00	38	3.00	2023-2.66
2.17	12.50	14.00	38	3.00	2023-2.17	2.67	14.00	17.00	38	3.00	2023-2.67
2.18	12.50	14.00	38	3.00	2023-2.18	2.68	14.00	17.00	38	3.00	2023-2.68
2.19	12.50	14.00	38	3.00	2023-2.19	2.69	14.00	17.00	38	3.00	2023-2.69
2.20	12.50	14.00	38	3.00	2023-2.20	2.70	14.00	17.00	38	3.00	2023-2.70
2.21	12.50	14.00	38	3.00	2023-2.21	2.71	14.00	17.00	38	3.00	2023-2.71
2.22	12.50	14.00	38	3.00	2023-2.22	2.72	14.00	17.00	38	3.00	2023-2.72
2.23	12.50	14.00	38	3.00	2023-2.23	2.73	14.00	17.00	38	3.00	2023-2.73
2.24	12.50	14.00	38	3.00	2023-2.24	2.74	14.00	17.00	38	3.00	2023-2.74
2.25	12.50	14.00	38	3.00	2023-2.25	2.75	14.00	17.00	38	3.00	2023-2.75
2.26	12.50	14.00	38	3.00	2023-2.26	2.76	14.00	17.00	38	3.00	2023-2.76
2.27	12.50	14.00	38	3.00	2023-2.27	2.77	14.00	17.00	38	3.00	2023-2.77
2.28	12.50	14.00	38	3.00	2023-2.28	2.78	14.00	17.00	38	3.00	2023-2.78
2.29	12.50	14.00	38	3.00	2023-2.29	2.79	14.00	17.00	38	3.00	2023-2.79
2.30	12.50	14.00	38	3.00	2023-2.30	2.80	14.00	17.00	38	3.00	2023-2.80
2.31	12.50	14.00	38	3.00	2023-2.31	2.81	14.00	17.00	38	3.00	2023-2.81
2.32	12.50	14.00	38	3.00	2023-2.32	2.82	14.00	17.00	38	3.00	2023-2.82
2.33	12.50	14.00	38	3.00	2023-2.33	2.83	14.00	17.00	38	3.00	2023-2.83
2.34	12.50	14.00	38	3.00	2023-2.34	2.84	14.00	17.00	38	3.00	2023-2.84
2.35	12.50	14.00	38	3.00	2023-2.35	2.85	14.00	17.00	38	3.00	2023-2.85
2.36	12.50	14.00	38	3.00	2023-2.36	2.86	14.00	17.00	38	3.00	2023-2.86
2.37	12.50	14.00	38	3.00	2023-2.37	2.87	14.00	17.00	38	3.00	2023-2.87
2.38	12.50	14.00	38	3.00	2023-2.38	2.88	14.00	17.00	38	3.00	2023-2.88
2.39	12.50	14.00	38	3.00	2023-2.39	2.89	14.00	17.00	38	3.00	2023-2.89
2.40	12.50	14.00	38	3.00	2023-2.40	2.90	14.00	17.00	38	3.00	2023-2.90
2.41	12.50	14.00	38	3.00	2023-2.41	2.91	14.00	17.00	38	3.00	2023-2.91
2.42	12.50	14.00	38	3.00	2023-2.42	2.92	14.00	17.00	38	3.00	2023-2.92
2.43	12.50	14.00	38	3.00	2023-2.43	2.93	14.00	17.00	38	3.00	2023-2.93
2.44	12.50	14.00	38	3.00	2023-2.44	2.94	14.00	17.00	38	3.00	2023-2.94
2.45	12.50	14.00	38	3.00	2023-2.45	2.95	14.00	17.00	38	3.00	2023-2.95
2.46	12.50	14.00	38	3.00	2023-2.46	2.96	14.00	17.00	38	3.00	2023-2.96
2.47	12.50	14.00	38	3.00	2023-2.47	2.97	14.00	17.00	38	3.00	2023-2.97
2.48	12.50	14.00	38	3.00	2023-2.48	2.98	14.00	17.00	38	3.00	2023-2.98
2.49	12.50	14.00	38	3.00	2023-2.49	2.99	14.00	17.00	38	3.00	2023-2.99
2.50	14.00	17.00	38	3.00	2023-2.50	3.00	14.00	17.00	38	3.00	2023-3.00

Micro-forets

Microbohrer

Micro drills

Ø 0.20 - Ø 1.09 mm

2026

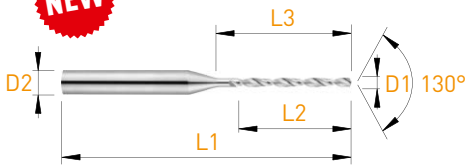

$\lambda^{25^\circ}$     Z=2    12xD1    MD  
VHM  
HM

D1 h6	L2	L3	L1	D2 h6	Art. N°
0.20	2.40	3.50	38	3.00	2026-0.20
0.21	2.52	3.50	38	3.00	2026-0.21
0.22	2.64	3.50	38	3.00	2026-0.22
0.23	2.76	3.50	38	3.00	2026-0.23
0.24	2.88	4.00	38	3.00	2026-0.24
0.25	3.00	4.00	38	3.00	2026-0.25
0.26	3.12	4.00	38	3.00	2026-0.26
0.27	3.24	4.00	38	3.00	2026-0.27
0.28	3.36	4.50	38	3.00	2026-0.28
0.29	3.48	4.50	38	3.00	2026-0.29
0.30	3.60	4.50	38	3.00	2026-0.30
0.31	3.72	4.50	38	3.00	2026-0.31
0.32	3.84	5.00	38	3.00	2026-0.32
0.33	3.96	5.00	38	3.00	2026-0.33
0.34	4.08	5.00	38	3.00	2026-0.34
0.35	4.20	5.00	38	3.00	2026-0.35
0.36	4.32	5.50	38	3.00	2026-0.36
0.37	4.44	5.50	38	3.00	2026-0.37
0.38	4.56	5.50	38	3.00	2026-0.38
0.39	4.68	5.50	38	3.00	2026-0.39
0.40	4.80	6.00	38	3.00	2026-0.40
0.41	4.92	6.00	38	3.00	2026-0.41
0.42	5.04	6.00	38	3.00	2026-0.42
0.43	5.16	6.00	38	3.00	2026-0.43
0.44	5.28	6.50	38	3.00	2026-0.44
0.45	5.40	6.50	38	3.00	2026-0.45
0.46	5.52	6.50	38	3.00	2026-0.46
0.47	5.64	6.50	38	3.00	2026-0.47
0.48	5.76	7.00	38	3.00	2026-0.48
0.49	5.88	7.00	38	3.00	2026-0.49
0.50	6.00	7.00	38	3.00	2026-0.50
0.51	6.12	7.00	38	3.00	2026-0.51
0.52	6.24	7.50	38	3.00	2026-0.52
0.53	6.36	7.50	38	3.00	2026-0.53
0.54	6.48	7.50	38	3.00	2026-0.54
0.55	6.60	7.50	38	3.00	2026-0.55
0.56	6.72	8.00	38	3.00	2026-0.56
0.57	6.84	8.00	38	3.00	2026-0.57
0.58	6.96	8.00	38	3.00	2026-0.58

D1 h6	L2	L3	L1	D2 h6	Art. N°
0.59	7.08	8.00	38	3.00	2026-0.59
0.60	7.20	9.00	38	3.00	2026-0.60
0.61	7.32	9.00	38	3.00	2026-0.61
0.62	7.44	9.00	38	3.00	2026-0.62
0.63	7.56	9.00	38	3.00	2026-0.63
0.64	7.68	9.50	38	3.00	2026-0.64
0.65	7.80	9.50	38	3.00	2026-0.65
0.66	7.92	9.50	38	3.00	2026-0.66
0.67	8.04	9.50	38	3.00	2026-0.67
0.68	8.16	10.00	38	3.00	2026-0.68
0.69	8.28	10.00	38	3.00	2026-0.69
0.70	8.40	10.00	38	3.00	2026-0.70
0.71	8.52	10.00	38	3.00	2026-0.71
0.72	8.64	10.50	38	3.00	2026-0.72
0.73	8.76	10.50	38	3.00	2026-0.73
0.74	8.88	10.50	38	3.00	2026-0.74
0.75	9.00	10.50	38	3.00	2026-0.75
0.76	9.12	11.00	38	3.00	2026-0.76
0.77	9.24	11.00	38	3.00	2026-0.77
0.78	9.36	11.00	38	3.00	2026-0.78
0.79	9.48	11.00	38	3.00	2026-0.79
0.80	9.60	11.50	38	3.00	2026-0.80
0.81	9.72	11.50	38	3.00	2026-0.81
0.82	9.84	11.50	38	3.00	2026-0.82
0.83	9.96	11.50	38	3.00	2026-0.83
0.84	10.08	12.00	38	3.00	2026-0.84
0.85	10.20	12.00	38	3.00	2026-0.85
0.86	10.32	12.00	38	3.00	2026-0.86
0.87	10.44	12.00	38	3.00	2026-0.87
0.88	10.56	12.50	38	3.00	2026-0.88
0.89	10.68	12.50	38	3.00	2026-0.89
0.90	10.80	12.50	38	3.00	2026-0.90
0.91	10.92	12.50	38	3.00	2026-0.91
0.92	11.04	13.00	38	3.00	2026-0.92
0.93	11.16	13.00	38	3.00	2026-0.93
0.94	11.28	13.00	38	3.00	2026-0.94
0.95	11.40	13.00	38	3.00	2026-0.95
0.96	11.52	13.50	38	3.00	2026-0.96
0.97	11.64	13.50	38	3.00	2026-0.97
0.98	11.76	13.50	38	3.00	2026-0.98
0.99	11.88	13.50	38	3.00	2026-0.99
1.00	12.00	14.50	38	3.00	2026-1.00
1.01	12.12	14.50	38	3.00	2026-1.01
1.02	12.24	14.50	38	3.00	2026-1.02
1.03	12.36	14.50	38	3.00	2026-1.03
1.04	12.48	15.00	38	3.00	2026-1.04
1.05	12.60	15.00	38	3.00	2026-1.05
1.06	12.72	15.00	38	3.00	2026-1.06
1.07	12.84	15.00	38	3.00	2026-1.07
1.08	12.96	15.50	38	3.00	2026-1.08
1.09	13.08	15.50	38	3.00	2026-1.09

D1 h6	L2	L3	L1	D2 h6	Art. N°
1.10	13.20	15.50	38	3.00	<b>2026-1.10</b>
1.11	13.32	15.50	38	3.00	<b>2026-1.11</b>
1.12	13.44	16.00	38	3.00	<b>2026-1.12</b>
1.13	13.56	16.00	38	3.00	<b>2026-1.13</b>
1.14	13.68	16.00	38	3.00	<b>2026-1.14</b>
1.15	13.80	16.00	38	3.00	<b>2026-1.15</b>
1.16	13.92	16.50	38	3.00	<b>2026-1.16</b>
1.17	14.04	16.50	38	3.00	<b>2026-1.17</b>
1.18	14.16	16.50	38	3.00	<b>2026-1.18</b>
1.19	14.28	16.50	38	3.00	<b>2026-1.19</b>
1.20	14.40	17.00	38	3.00	<b>2026-1.20</b>
1.21	14.52	17.00	38	3.00	<b>2026-1.21</b>
1.22	14.64	17.00	38	3.00	<b>2026-1.22</b>
1.23	14.76	17.00	38	3.00	<b>2026-1.23</b>
1.24	14.88	17.50	38	3.00	<b>2026-1.24</b>
1.25	15.00	17.50	38	3.00	<b>2026-1.25</b>
1.26	15.12	17.50	50	3.00	<b>2026-1.26</b>
1.27	15.24	17.50	50	3.00	<b>2026-1.27</b>
1.28	15.36	18.00	50	3.00	<b>2026-1.28</b>
1.29	15.48	18.00	50	3.00	<b>2026-1.29</b>
1.30	15.60	18.00	50	3.00	<b>2026-1.30</b>
1.31	15.72	18.00	50	3.00	<b>2026-1.31</b>
1.32	15.84	18.50	50	3.00	<b>2026-1.32</b>
1.33	15.96	18.50	50	3.00	<b>2026-1.33</b>
1.34	16.08	18.50	50	3.00	<b>2026-1.34</b>
1.35	16.20	18.50	50	3.00	<b>2026-1.35</b>
1.36	16.32	19.00	50	3.00	<b>2026-1.36</b>
1.37	16.44	19.00	50	3.00	<b>2026-1.37</b>
1.38	16.56	19.00	50	3.00	<b>2026-1.38</b>
1.39	16.68	19.00	50	3.00	<b>2026-1.39</b>
1.40	16.80	19.50	50	3.00	<b>2026-1.40</b>
1.41	16.92	19.50	50	3.00	<b>2026-1.41</b>
1.42	17.04	19.50	50	3.00	<b>2026-1.42</b>
1.43	17.16	19.50	50	3.00	<b>2026-1.43</b>
1.44	17.28	20.00	50	3.00	<b>2026-1.44</b>
1.45	17.40	20.00	50	3.00	<b>2026-1.45</b>
1.46	17.52	20.00	50	3.00	<b>2026-1.46</b>
1.47	17.64	20.00	50	3.00	<b>2026-1.47</b>
1.48	17.76	20.50	50	3.00	<b>2026-1.48</b>
1.49	17.88	20.50	50	3.00	<b>2026-1.49</b>
1.50	18.00	21.00	50	3.00	<b>2026-1.50</b>
1.51	18.12	21.00	50	3.00	<b>2026-1.51</b>
1.52	18.24	21.00	50	3.00	<b>2026-1.52</b>
1.53	18.36	21.00	50	3.00	<b>2026-1.53</b>
1.54	18.48	21.50	50	3.00	<b>2026-1.54</b>
1.55	18.60	21.50	50	3.00	<b>2026-1.55</b>
1.56	18.72	21.50	50	3.00	<b>2026-1.56</b>
1.57	18.84	21.50	50	3.00	<b>2026-1.57</b>
1.58	18.96	22.00	50	3.00	<b>2026-1.58</b>
1.59	19.08	22.00	50	3.00	<b>2026-1.59</b>
1.60	19.20	22.00	50	3.00	<b>2026-1.60</b>

D1 h6	L2	L3	L1	D2 h6	Art. N°
1.61	19.32	22.00	50	3.00	<b>2026-1.61</b>
1.62	19.44	22.50	50	3.00	<b>2026-1.62</b>
1.63	19.56	22.50	50	3.00	<b>2026-1.63</b>
1.64	19.68	22.50	50	3.00	<b>2026-1.64</b>
1.65	19.80	22.50	50	3.00	<b>2026-1.65</b>
1.66	19.92	23.00	50	3.00	<b>2026-1.66</b>
1.67	20.04	23.00	50	3.00	<b>2026-1.67</b>
1.68	20.16	23.00	50	3.00	<b>2026-1.68</b>
1.69	20.28	23.00	50	3.00	<b>2026-1.69</b>
1.70	20.40	23.50	50	3.00	<b>2026-1.70</b>
1.71	20.52	23.50	50	3.00	<b>2026-1.71</b>
1.72	20.64	23.50	50	3.00	<b>2026-1.72</b>
1.73	20.76	23.50	50	3.00	<b>2026-1.73</b>
1.74	20.88	24.00	50	3.00	<b>2026-1.74</b>
1.75	21.00	24.00	50	3.00	<b>2026-1.75</b>
1.76	21.12	24.00	50	3.00	<b>2026-1.76</b>
1.77	21.24	24.00	50	3.00	<b>2026-1.77</b>
1.78	21.36	24.50	50	3.00	<b>2026-1.78</b>
1.79	21.48	24.50	50	3.00	<b>2026-1.79</b>
1.80	21.60	25.00	50	3.00	<b>2026-1.80</b>
1.81	21.72	25.00	50	3.00	<b>2026-1.81</b>
1.82	21.84	25.00	50	3.00	<b>2026-1.82</b>
1.83	21.96	25.00	50	3.00	<b>2026-1.83</b>
1.84	22.08	25.50	50	3.00	<b>2026-1.84</b>
1.85	22.20	25.50	50	3.00	<b>2026-1.85</b>
1.86	22.32	25.50	50	3.00	<b>2026-1.86</b>
1.87	22.44	25.50	50	3.00	<b>2026-1.87</b>
1.88	22.56	26.00	50	3.00	<b>2026-1.88</b>
1.89	22.68	26.00	50	3.00	<b>2026-1.89</b>
1.90	22.80	26.00	50	3.00	<b>2026-1.90</b>
1.91	22.92	26.00	50	3.00	<b>2026-1.91</b>
1.92	23.04	26.50	50	3.00	<b>2026-1.92</b>
1.93	23.16	26.50	50	3.00	<b>2026-1.93</b>
1.94	23.28	26.50	50	3.00	<b>2026-1.94</b>
1.95	23.40	26.50	50	3.00	<b>2026-1.95</b>
1.96	23.52	27.00	50	3.00	<b>2026-1.96</b>
1.97	23.64	27.00	50	3.00	<b>2026-1.97</b>
1.98	23.76	27.00	50	3.00	<b>2026-1.98</b>
1.99	23.88	27.00	50	3.00	<b>2026-1.99</b>
2.00	24.00	27.00	50	3.00	<b>2026-2.00</b>



Micro-forets

Microbohrer

Micro drills

Ø 0.20 - Ø 1.09 mm

2030

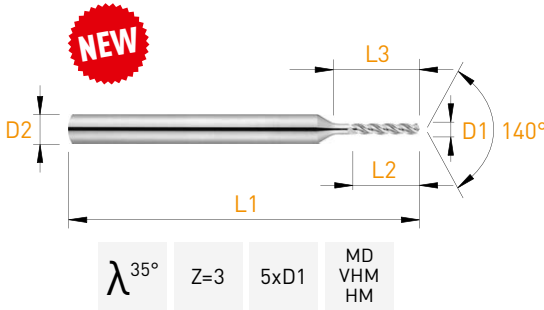

D1 h <sub>6</sub>	L2	L3	L1	D2 h <sub>6</sub>	Art. N°
0.20	1.00	1.50	38	3.00	<b>2030-0.20</b>
0.21	1.05	1.50	38	3.00	<b>2030-0.21</b>
0.22	1.10	1.60	38	3.00	<b>2030-0.22</b>
0.23	1.15	1.60	38	3.00	<b>2030-0.23</b>
0.24	1.20	1.70	38	3.00	<b>2030-0.24</b>
0.25	1.25	1.70	38	3.00	<b>2030-0.25</b>
0.26	1.30	1.80	38	3.00	<b>2030-0.26</b>
0.27	1.35	1.80	38	3.00	<b>2030-0.27</b>
0.28	1.40	1.90	38	3.00	<b>2030-0.28</b>
0.29	1.45	1.90	38	3.00	<b>2030-0.29</b>
0.30	1.50	2.00	38	3.00	<b>2030-0.30</b>
0.31	1.55	2.00	38	3.00	<b>2030-0.31</b>
0.32	1.60	2.10	38	3.00	<b>2030-0.32</b>
0.33	1.65	2.10	38	3.00	<b>2030-0.33</b>
0.34	1.70	2.20	38	3.00	<b>2030-0.34</b>
0.35	1.75	2.20	38	3.00	<b>2030-0.35</b>
0.36	1.80	2.30	38	3.00	<b>2030-0.36</b>
0.37	1.85	2.30	38	3.00	<b>2030-0.37</b>
0.38	1.90	2.40	38	3.00	<b>2030-0.38</b>
0.39	1.95	2.40	38	3.00	<b>2030-0.39</b>
0.40	2.00	2.50	38	3.00	<b>2030-0.40</b>
0.41	2.05	2.50	38	3.00	<b>2030-0.41</b>
0.42	2.10	2.60	38	3.00	<b>2030-0.42</b>
0.43	2.15	2.60	38	3.00	<b>2030-0.43</b>
0.44	2.20	2.70	38	3.00	<b>2030-0.44</b>
0.45	2.25	2.70	38	3.00	<b>2030-0.45</b>
0.46	2.30	2.80	38	3.00	<b>2030-0.46</b>
0.47	2.35	2.80	38	3.00	<b>2030-0.47</b>
0.48	2.40	2.90	38	3.00	<b>2030-0.48</b>
0.49	2.45	2.90	38	3.00	<b>2030-0.49</b>
0.50	2.50	3.00	38	3.00	<b>2030-0.50</b>
0.51	2.55	3.00	38	3.00	<b>2030-0.51</b>
0.52	2.60	3.10	38	3.00	<b>2030-0.52</b>
0.53	2.65	3.10	38	3.00	<b>2030-0.53</b>
0.54	2.70	3.20	38	3.00	<b>2030-0.54</b>
0.55	2.75	3.20	38	3.00	<b>2030-0.55</b>
0.56	2.80	3.30	38	3.00	<b>2030-0.56</b>
0.57	2.85	3.30	38	3.00	<b>2030-0.57</b>
0.58	2.90	3.40	38	3.00	<b>2030-0.58</b>

D1 h <sub>6</sub>	L2	L3	L1	D2 h <sub>6</sub>	Art. N°
0.59	2.95	3.40	38	3.00	<b>2030-0.59</b>
0.60	3.00	3.50	38	3.00	<b>2030-0.60</b>
0.61	3.05	3.50	38	3.00	<b>2030-0.61</b>
0.62	3.10	3.60	38	3.00	<b>2030-0.62</b>
0.63	3.15	3.60	38	3.00	<b>2030-0.63</b>
0.64	3.20	3.70	38	3.00	<b>2030-0.64</b>
0.65	3.25	3.70	38	3.00	<b>2030-0.65</b>
0.66	3.30	3.80	38	3.00	<b>2030-0.66</b>
0.67	3.35	3.80	38	3.00	<b>2030-0.67</b>
0.68	3.40	3.90	38	3.00	<b>2030-0.68</b>
0.69	3.45	3.90	38	3.00	<b>2030-0.69</b>
0.70	3.50	4.00	38	3.00	<b>2030-0.70</b>
0.71	3.55	4.00	38	3.00	<b>2030-0.71</b>
0.72	3.60	4.10	38	3.00	<b>2030-0.72</b>
0.73	3.65	4.10	38	3.00	<b>2030-0.73</b>
0.74	3.70	4.20	38	3.00	<b>2030-0.74</b>
0.75	3.75	4.20	38	3.00	<b>2030-0.75</b>
0.76	3.80	4.30	38	3.00	<b>2030-0.76</b>
0.77	3.85	4.30	38	3.00	<b>2030-0.77</b>
0.78	3.90	4.40	38	3.00	<b>2030-0.78</b>
0.79	3.95	4.40	38	3.00	<b>2030-0.79</b>
0.80	4.00	4.50	38	3.00	<b>2030-0.80</b>
0.81	4.05	4.50	38	3.00	<b>2030-0.81</b>
0.82	4.10	4.60	38	3.00	<b>2030-0.82</b>
0.83	4.15	4.60	38	3.00	<b>2030-0.83</b>
0.84	4.20	4.70	38	3.00	<b>2030-0.84</b>
0.85	4.25	4.70	38	3.00	<b>2030-0.85</b>
0.86	4.30	4.80	38	3.00	<b>2030-0.86</b>
0.87	4.35	4.80	38	3.00	<b>2030-0.87</b>
0.88	4.40	4.90	38	3.00	<b>2030-0.88</b>
0.89	4.45	4.90	38	3.00	<b>2030-0.89</b>
0.90	4.50	5.00	38	3.00	<b>2030-0.90</b>
0.91	4.55	5.00	38	3.00	<b>2030-0.91</b>
0.92	4.60	5.10	38	3.00	<b>2030-0.92</b>
0.93	4.65	5.10	38	3.00	<b>2030-0.93</b>
0.94	4.70	5.20	38	3.00	<b>2030-0.94</b>
0.95	4.75	5.20	38	3.00	<b>2030-0.95</b>
0.96	4.80	5.30	38	3.00	<b>2030-0.96</b>
0.97	4.85	5.30	38	3.00	<b>2030-0.97</b>
0.98	4.90	5.40	38	3.00	<b>2030-0.98</b>
0.99	4.95	5.40	38	3.00	<b>2030-0.99</b>
1.00	5.00	6.50	38	3.00	<b>2030-1.00</b>
1.01	5.05	6.50	38	3.00	<b>2030-1.01</b>
1.02	5.10	6.50	38	3.00	<b>2030-1.02</b>
1.03	5.15	6.50	38	3.00	<b>2030-1.03</b>
1.04	5.20	6.50	38	3.00	<b>2030-1.04</b>
1.05	5.25	6.50	38	3.00	<b>2030-1.05</b>
1.06	5.30	6.50	38	3.00	<b>2030-1.06</b>
1.07	5.35	7.50	38	3.00	<b>2030-1.07</b>
1.08	5.40	7.50	38	3.00	<b>2030-1.08</b>
1.09	5.45	7.50	38	3.00	<b>2030-1.09</b>

D1 h6	L2	L3	L1	D2 h6	Art. N°
1.10	5.50	7.50	38	3.00	2030-1.10
1.11	5.55	7.50	38	3.00	2030-1.11
1.12	5.60	7.50	38	3.00	2030-1.12
1.13	5.65	7.50	38	3.00	2030-1.13
1.14	5.70	7.50	38	3.00	2030-1.14
1.15	5.75	7.50	38	3.00	2030-1.15
1.16	5.80	7.50	38	3.00	2030-1.16
1.17	5.85	7.50	38	3.00	2030-1.17
1.18	5.90	8.50	38	3.00	2030-1.18
1.19	5.95	8.50	38	3.00	2030-1.19
1.20	6.00	8.50	38	3.00	2030-1.20
1.21	6.05	8.50	38	3.00	2030-1.21
1.22	6.10	8.50	38	3.00	2030-1.22
1.23	6.15	8.50	38	3.00	2030-1.23
1.24	6.20	8.50	38	3.00	2030-1.24
1.25	6.25	8.50	38	3.00	2030-1.25
1.26	6.30	8.50	38	3.00	2030-1.26
1.27	6.35	8.50	38	3.00	2030-1.27
1.28	6.40	8.50	38	3.00	2030-1.28
1.29	6.45	8.50	38	3.00	2030-1.29
1.30	6.50	8.50	38	3.00	2030-1.30
1.31	6.55	8.50	38	3.00	2030-1.31
1.32	6.60	8.50	38	3.00	2030-1.32
1.33	6.65	9.50	38	3.00	2030-1.33
1.34	6.70	9.50	38	3.00	2030-1.34
1.35	6.75	9.50	38	3.00	2030-1.35
1.36	6.80	9.50	38	3.00	2030-1.36
1.37	6.85	9.50	38	3.00	2030-1.37
1.38	6.90	9.50	38	3.00	2030-1.38
1.39	6.95	9.50	38	3.00	2030-1.39
1.40	7.00	9.50	38	3.00	2030-1.40
1.41	7.05	9.50	38	3.00	2030-1.41
1.42	7.10	9.50	38	3.00	2030-1.42
1.43	7.15	9.50	38	3.00	2030-1.43
1.44	7.20	9.50	38	3.00	2030-1.44
1.45	7.25	9.50	38	3.00	2030-1.45
1.46	7.30	9.50	38	3.00	2030-1.46
1.47	7.35	9.50	38	3.00	2030-1.47
1.48	7.40	9.50	38	3.00	2030-1.48
1.49	7.45	9.50	38	3.00	2030-1.49
1.50	7.50	9.50	38	3.00	2030-1.50
1.51	7.55	10.50	38	3.00	2030-1.51
1.52	7.60	10.50	38	3.00	2030-1.52
1.53	7.65	10.50	38	3.00	2030-1.53
1.54	7.70	10.50	38	3.00	2030-1.54
1.55	7.75	10.50	38	3.00	2030-1.55
1.56	7.80	10.50	38	3.00	2030-1.56
1.57	7.85	10.50	38	3.00	2030-1.57
1.58	7.90	10.50	38	3.00	2030-1.58
1.59	7.95	10.50	38	3.00	2030-1.59
1.60	8.00	10.50	38	3.00	2030-1.60

D1 h6	L2	L3	L1	D2 h6	Art. N°
1.61	8.05	10.50	38	3.00	2030-1.61
1.62	8.10	10.50	38	3.00	2030-1.62
1.63	8.15	10.50	38	3.00	2030-1.63
1.64	8.20	10.50	38	3.00	2030-1.64
1.65	8.25	10.50	38	3.00	2030-1.65
1.66	8.30	10.50	38	3.00	2030-1.66
1.67	8.35	10.50	38	3.00	2030-1.67
1.68	8.40	10.50	38	3.00	2030-1.68
1.69	8.45	10.50	38	3.00	2030-1.69
1.70	8.50	10.50	38	3.00	2030-1.70
1.71	8.55	11.50	38	3.00	2030-1.71
1.72	8.60	11.50	38	3.00	2030-1.72
1.73	8.65	11.50	38	3.00	2030-1.73
1.74	8.70	11.50	38	3.00	2030-1.74
1.75	8.75	11.50	38	3.00	2030-1.75
1.76	8.80	11.50	38	3.00	2030-1.76
1.77	8.85	11.50	38	3.00	2030-1.77
1.78	8.90	11.50	38	3.00	2030-1.78
1.79	8.95	11.50	38	3.00	2030-1.79
1.80	9.00	11.50	38	3.00	2030-1.80
1.81	9.05	11.50	38	3.00	2030-1.81
1.82	9.10	11.50	38	3.00	2030-1.82
1.83	9.15	11.50	38	3.00	2030-1.83
1.84	9.20	11.50	38	3.00	2030-1.84
1.85	9.25	11.50	38	3.00	2030-1.85
1.86	9.30	11.50	38	3.00	2030-1.86
1.87	9.35	11.50	38	3.00	2030-1.87
1.88	9.40	11.50	38	3.00	2030-1.88
1.89	9.45	11.50	38	3.00	2030-1.89
1.90	9.50	11.50	38	3.00	2030-1.90
1.91	9.55	12.50	38	3.00	2030-1.91
1.92	9.60	12.50	38	3.00	2030-1.92
1.93	9.65	12.50	38	3.00	2030-1.93
1.94	9.70	12.50	38	3.00	2030-1.94
1.95	9.75	12.50	38	3.00	2030-1.95
1.96	9.80	12.50	38	3.00	2030-1.96
1.97	9.85	12.50	38	3.00	2030-1.97
1.98	9.90	12.50	38	3.00	2030-1.98
1.99	9.95	12.50	38	3.00	2030-1.99
2.00	10.00	12.50	38	3.00	2030-2.00
2.01	10.05	12.50	38	3.00	2030-2.01
2.02	10.10	12.50	38	3.00	2030-2.02
2.03	10.15	12.50	38	3.00	2030-2.03
2.04	10.20	12.50	38	3.00	2030-2.04
2.05	10.25	12.50	38	3.00	2030-2.05
2.06	10.30	12.50	38	3.00	2030-2.06
2.07	10.35	12.50	38	3.00	2030-2.07
2.08	10.40	12.50	38	3.00	2030-2.08
2.09	10.45	12.50	38	3.00	2030-2.09
2.10	10.50	12.50	38	3.00	2030-2.10
2.11	10.55	12.50	38	3.00	2030-2.11

Micro-forets

Microbohrer

Micro drills

Ø 2.12 - Ø 2.99 mm

2030

D1 h6	L2	L3	L1	D2 h6	Art. N°
2.12	10.60	12.50	38	3.00	<b>2030-2.12</b>
2.13	10.65	13.50	38	3.00	<b>2030-2.13</b>
2.14	10.70	13.50	38	3.00	<b>2030-2.14</b>
2.15	10.75	13.50	38	3.00	<b>2030-2.15</b>
2.16	10.80	13.50	38	3.00	<b>2030-2.16</b>
2.17	10.85	13.50	38	3.00	<b>2030-2.17</b>
2.18	10.90	13.50	38	3.00	<b>2030-2.18</b>
2.19	10.95	13.50	38	3.00	<b>2030-2.19</b>
2.20	11.00	13.50	38	3.00	<b>2030-2.20</b>
2.21	11.05	13.50	38	3.00	<b>2030-2.21</b>
2.22	11.10	13.50	38	3.00	<b>2030-2.22</b>
2.23	11.15	13.50	38	3.00	<b>2030-2.23</b>
2.24	11.20	13.50	38	3.00	<b>2030-2.24</b>
2.25	11.25	13.50	38	3.00	<b>2030-2.25</b>
2.26	11.30	13.50	38	3.00	<b>2030-2.26</b>
2.27	11.35	13.50	38	3.00	<b>2030-2.27</b>
2.28	11.40	13.50	38	3.00	<b>2030-2.28</b>
2.29	11.45	13.50	38	3.00	<b>2030-2.29</b>
2.30	11.50	13.50	38	3.00	<b>2030-2.30</b>
2.31	11.55	13.50	38	3.00	<b>2030-2.31</b>
2.32	11.60	13.50	38	3.00	<b>2030-2.32</b>
2.33	11.65	13.50	38	3.00	<b>2030-2.33</b>
2.34	11.70	13.50	38	3.00	<b>2030-2.34</b>
2.35	11.75	13.50	38	3.00	<b>2030-2.35</b>
2.36	11.80	13.50	38	3.00	<b>2030-2.36</b>
2.37	11.85	14.50	38	3.00	<b>2030-2.37</b>
2.38	11.90	14.50	38	3.00	<b>2030-2.38</b>
2.39	11.95	14.50	38	3.00	<b>2030-2.39</b>
2.40	12.00	14.50	38	3.00	<b>2030-2.40</b>
2.41	12.05	14.50	38	3.00	<b>2030-2.41</b>
2.42	12.10	14.50	38	3.00	<b>2030-2.42</b>
2.43	12.15	14.50	38	3.00	<b>2030-2.43</b>
2.44	12.20	14.50	38	3.00	<b>2030-2.44</b>
2.45	12.25	14.50	38	3.00	<b>2030-2.45</b>
2.46	12.30	14.50	38	3.00	<b>2030-2.46</b>
2.47	12.35	14.50	38	3.00	<b>2030-2.47</b>
2.48	12.40	14.50	38	3.00	<b>2030-2.48</b>
2.49	12.45	14.50	38	3.00	<b>2030-2.49</b>
2.50	12.50	14.50	38	3.00	<b>2030-2.50</b>
2.51	12.55	14.50	38	3.00	<b>2030-2.51</b>
2.52	12.60	14.50	38	3.00	<b>2030-2.52</b>
2.53	12.65	14.50	38	3.00	<b>2030-2.53</b>
2.54	12.70	14.50	38	3.00	<b>2030-2.54</b>
2.55	12.75	14.50	38	3.00	<b>2030-2.55</b>
2.56	12.80	14.50	38	3.00	<b>2030-2.56</b>
2.57	12.85	14.50	38	3.00	<b>2030-2.57</b>
2.58	12.90	14.50	38	3.00	<b>2030-2.58</b>
2.59	12.95	14.50	38	3.00	<b>2030-2.59</b>
2.60	13.00	14.50	38	3.00	<b>2030-2.60</b>
2.61	13.05	14.50	38	3.00	<b>2030-2.61</b>
2.62	13.10	14.50	38	3.00	<b>2030-2.62</b>

D1 h6	L2	L3	L1	D2 h6	Art. N°
2.63	13.15	14.50	38	3.00	<b>2030-2.63</b>
2.64	13.20	14.50	38	3.00	<b>2030-2.64</b>
2.65	13.25	14.50	38	3.00	<b>2030-2.65</b>
2.66	13.30	16.50	38	3.00	<b>2030-2.66</b>
2.67	13.35	16.50	38	3.00	<b>2030-2.67</b>
2.68	13.40	16.50	38	3.00	<b>2030-2.68</b>
2.69	13.45	16.50	38	3.00	<b>2030-2.69</b>
2.70	13.50	16.50	38	3.00	<b>2030-2.70</b>
2.71	13.55	16.55	38	3.00	<b>2030-2.71</b>
2.72	13.60	16.50	38	3.00	<b>2030-2.72</b>
2.73	13.65	16.50	38	3.00	<b>2030-2.73</b>
2.74	13.70	16.50	38	3.00	<b>2030-2.74</b>
2.75	13.75	16.50	38	3.00	<b>2030-2.75</b>
2.76	13.80	16.50	38	3.00	<b>2030-2.76</b>
2.77	13.85	16.50	38	3.00	<b>2030-2.77</b>
2.78	13.90	16.50	38	3.00	<b>2030-2.78</b>
2.79	13.95	16.50	38	3.00	<b>2030-2.79</b>
2.80	14.00	16.50	38	3.00	<b>2030-2.80</b>
2.81	14.05	16.50	38	3.00	<b>2030-2.81</b>
2.82	14.10	16.50	38	3.00	<b>2030-2.82</b>
2.83	14.15	16.50	38	3.00	<b>2030-2.83</b>
2.84	14.20	16.50	38	3.00	<b>2030-2.84</b>
2.85	14.25	16.50	38	3.00	<b>2030-2.85</b>
2.86	14.30	16.50	38	3.00	<b>2030-2.86</b>
2.87	14.35	16.50	38	3.00	<b>2030-2.87</b>
2.88	14.40	16.50	38	3.00	<b>2030-2.88</b>
2.89	14.45	16.50	38	3.00	<b>2030-2.89</b>
2.90	14.50	16.50	38	3.00	<b>2030-2.90</b>
2.91	14.55	16.50	38	3.00	<b>2030-2.91</b>
2.92	14.60	16.50	38	3.00	<b>2030-2.92</b>
2.93	14.65	16.50	38	3.00	<b>2030-2.93</b>
2.94	14.70	16.50	38	3.00	<b>2030-2.94</b>
2.95	14.75	16.50	38	3.00	<b>2030-2.95</b>
2.96	14.80	16.50	38	3.00	<b>2030-2.96</b>
2.97	14.85	16.50	38	3.00	<b>2030-2.97</b>
2.98	14.90	16.50	38	3.00	<b>2030-2.98</b>
2.99	14.95	16.50	38	3.00	<b>2030-2.99</b>

# MICRO-Line

Fraises à graver

Gravierfräser

Engraving mills

Paramètres de coupe indicatifs

Empfohlene Schnittwerte

Standard machining data

Matière Werkstoff Material	VC [m/min]	
Acier Stahl Steel < 700 N/mm <sup>2</sup>	80 - 180	recommended feed rate for rotation speed between 20'000 and 30'000 RPM
Acier Stahl Steel > 700 N/mm <sup>2</sup>	70 - 150	
Acier inoxydable Rostfreistahl Stainless steel	70 - 150	
Titane Titan Titanium	70 - 130	
Aluminium	80 - 250	
Cuivre Kupfer Copper	70 - 150	
Laiton Messing Brass	80 - 200	
Or Gold Gold	80 - 200	

Fraises à graver

Gravierfräser

Engraving mills

E300-P

**NEW**

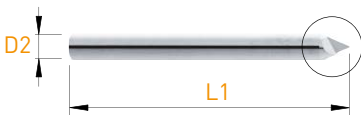
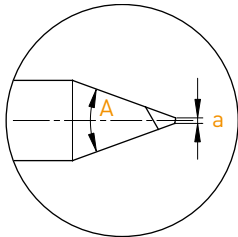

MD  
VHM  
HM

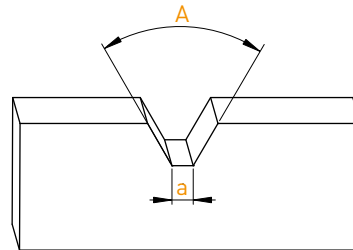

A	a *in steps of 0.01 mm	D2 h6	L1	Art. N°
30°	0.02-0.10* / 0.12 / 0.15	3.00	33	E330-P-_(a)
40°	0.02-0.10* / 0.12 / 0.15	3.00	33	E340-P-_(a)
50°	0.02-0.10* / 0.12 / 0.15	3.00	33	E350-P-_(a)
60°	0.02-0.10* / 0.12 / 0.15	3.00	33	E360-P-_(a)
90°	0.02-0.10* / 0.12 / 0.15	3.00	33	E390-P-_(a)

Fraises à graver

Gravierfräser

Engraving mills

## E300-R

**NEW**

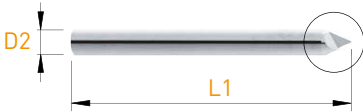
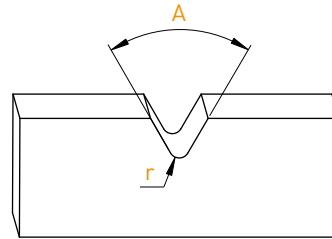
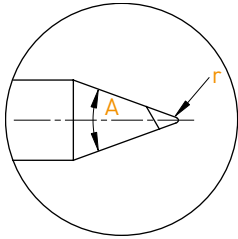

MD  
VHM  
HM

A	r *in steps of 0.01 mm	D2 h6	L1	Art. N°
30°	0.04-0.10*	3.00	33	E330-R-_(r)
40°	0.04-0.10*	3.00	33	E340-R-_(r)
50°	0.04-0.10*	3.00	33	E350-R-_(r)
60°	0.04-0.10*	3.00	33	E360-R-_(r)
90°	0.04-0.10*	3.00	33	E390-R-_(r)

Fraises à graver

Gravierfräser

Engraving mills

## E900-P

**NEW**

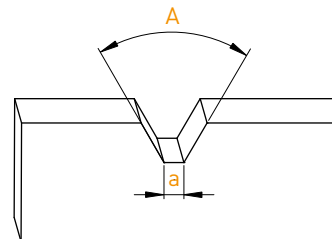
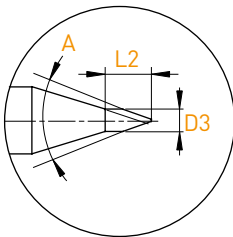

MD  
VHM  
HM

A	a *in steps of 0.01 mm	D3	L2	D2 h6	L1	Art. N°
30°	0.04-0.10*	0.60	1.8	3.00	33	E930-P-_(a)
40°	0.04-0.10*	0.60	1.8	3.00	33	E940-P-_(a)
50°	0.04-0.10*	1.00	2.0	3.00	33	E950-P-_(a)
60°	0.04-0.10*	1.00	2.0	3.00	33	E960-P-_(a)

# MICRO-Line

Fraises en bout de finition

Schlicht Schafffräser

Finishing end mills

Paramètres de coupe indicatifs

Empfohlene Schnittwerte

Standard machining data

		Shank	Z	Spiral	Type	page	
		∅ 6 mm	Z = 3	30°	3336-HA	8.29	
				30°	3337-HA	8.29	
				30°	3330-S	8.30	
		D1 = D2		Z = 3	30°	3330	8.30
					30°	3231	8.31
		D1 = D2		Z = 3	30°	3331	8.31
					45°	3341	8.32
					60°	3361	8.32
					30°	3431	8.33
				Z = 4	45°	3441	8.33
30°	3238				8.34		
D1 = D2		Z = 3	30°	3338	8.34		
			30°	3383	8.35		
		∅ 6 mm	Z = 3	30°	3830	8.35	
		∅ 10 mm	Z = 10	30°	3911	8.36	
		∅ 3 mm	Z = 3	0°	1901/3901	8.36	
		D1 = D2	Z = 4	0°			

Matière Werkstoff Material	VC (m/min)	fz [mm/z]	
		∅ 2 - 4	∅ 4 - 6
Acier Stahl Steel < 700 N/mm <sup>2</sup>	60 - 100	0.010 - 0.030	0.015 - 0.040
Acier Stahl Steel > 700 N/mm <sup>2</sup>	40 - 70	0.008 - 0.020	0.010 - 0.030
Acier inoxydable Rostfreistahl Stainless steel	40 - 80	0.010 - 0.030	0.015 - 0.040
Titane Titan Titanium	25 - 50	0.010 - 0.030	0.015 - 0.040
Aluminium	100 - 250	0.015 - 0.050	0.020 - 0.060
Cuivre Kupfer Copper	80 - 160	0.010 - 0.040	0.020 - 0.060
Laiton Messing Brass	100 - 200	0.015 - 0.040	0.030 - 0.070

Fraises en bout de finition

Schlicht Schafffräser

Finishing end mills

## 3336-HA / 3337-HA

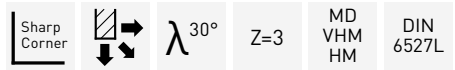
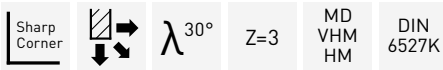
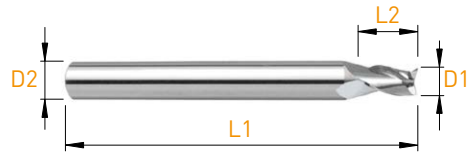
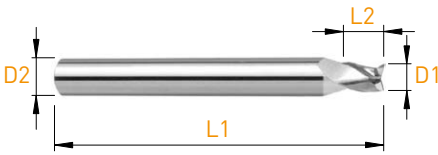

D1 h10	L2	D2 h6	L1	Art. N°
1.50	3.0	6.00	50	<b>3336-HA-1.5</b>
1.80	3.0	6.00	50	<b>3336-HA-1.8</b>
2.00	3.0	6.00	50	<b>3336-HA-2.0</b>
2.50	3.0	6.00	50	<b>3336-HA-2.5</b>
2.80	4.0	6.00	50	<b>3336-HA-2.8</b>
3.00	4.0	6.00	50	<b>3336-HA-3.0</b>
3.50	4.0	6.00	50	<b>3336-HA-3.5</b>
3.80	5.0	6.00	54	<b>3336-HA-3.8</b>
4.00	5.0	6.00	54	<b>3336-HA-4.0</b>
4.50	5.0	6.00	54	<b>3336-HA-4.5</b>
4.80	6.0	6.00	54	<b>3336-HA-4.8</b>
5.00	6.0	6.00	54	<b>3336-HA-5.0</b>
5.50	7.0	6.00	54	<b>3336-HA-5.5</b>
5.80	7.0	6.00	54	<b>3336-HA-5.8</b>
6.00	7.0	6.00	54	<b>3336-HA-6.0</b>

D1 h10	L2	D2 h6	L1	Art. N°
1.50	6.0	6.00	57	<b>3337-HA-1.5</b>
1.80	6.0	6.00	57	<b>3337-HA-1.8</b>
2.00	6.0	6.00	57	<b>3337-HA-2.0</b>
2.50	6.0	6.00	57	<b>3337-HA-2.5</b>
2.80	7.0	6.00	57	<b>3337-HA-2.8</b>
3.00	7.0	6.00	57	<b>3337-HA-3.0</b>
3.50	7.0	6.00	57	<b>3337-HA-3.5</b>
3.80	8.0	6.00	57	<b>3337-HA-3.8</b>
4.00	8.0	6.00	57	<b>3337-HA-4.0</b>
4.50	8.0	6.00	57	<b>3337-HA-4.5</b>
4.80	10.0	6.00	57	<b>3337-HA-4.8</b>
5.00	10.0	6.00	57	<b>3337-HA-5.0</b>
5.50	10.0	6.00	57	<b>3337-HA-5.5</b>
5.80	10.0	6.00	57	<b>3337-HA-5.8</b>
6.00	10.0	6.00	57	<b>3337-HA-6.0</b>

# MICRO-Line

Fraises en bout de finition

Schlicht Schafffräser

Finishing end mills

3330-S / 3330



D1 h10	L2	D2 h6	L1	Art. N°
1.00	3.0	6.00	40	<b>3330-S-1.0</b>
1.50	3.0	6.00	40	<b>3330-S-1.5</b>
2.00	3.0	6.00	40	<b>3330-S-2.0</b>
2.50	3.0	6.00	40	<b>3330-S-2.5</b>
3.00	4.0	6.00	40	<b>3330-S-3.0</b>
3.50	4.0	6.00	40	<b>3330-S-3.5</b>
4.00	5.0	6.00	40	<b>3330-S-4.0</b>
4.50	5.0	6.00	40	<b>3330-S-4.5</b>
5.00	6.0	6.00	40	<b>3330-S-5.0</b>
6.00	7.0	6.00	40	<b>3330-S-6.0</b>



D1 e9	L2	D2 h6	L1	Art. N°
3.00	3.0	3.00	39	<b>3330-3.0</b>
4.00	4.0	4.00	50	<b>3330-4.0</b>
5.00	5.0	5.00	50	<b>3330-5.0</b>
6.00	6.0	6.00	50	<b>3330-6.0</b>
8.00	8.0	8.00	58	<b>3330-8.0</b>
10.00	10.0	10.00	66	<b>3330-10.0</b>
12.00	12.0	12.00	73	<b>3330-12.0</b>
16.00	16.0	16.00	82	<b>3330-16.0</b>
20.00	20.0	20.00	92	<b>3330-20.0</b>



Fraises en bout de finition

Schlicht Schafffräser

Finishing end mills

3231 / 3331

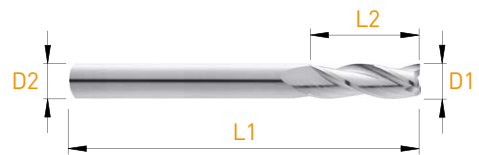
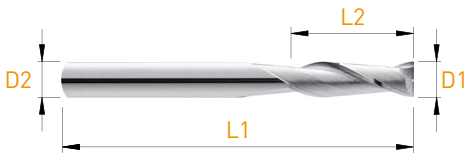

D1 e9	L2	D2 h6	L1	Art. N°
2.00	8.0	2.00	32	<b>3231-2.0</b>
2.50	8.0	2.50	32	<b>3231-2.5</b>
3.00	12.0	3.00	32	<b>3231-3.0</b>
3.50	12.0	3.50	32	<b>3231-3.5</b>
4.00	12.0	4.00	40	<b>3231-4.0</b>
4.50	14.0	4.50	50	<b>3231-4.5</b>
5.00	14.0	5.00	50	<b>3231-5.0</b>
6.00	16.0	6.00	50	<b>3231-6.0</b>

D1 e9	L2	D2 h6	L1	Art. N°
2.00	8.0	2.00	32	<b>3331-2.0</b>
2.50	8.0	2.50	32	<b>3331-2.5</b>
3.00	12.0	3.00	32	<b>3331-3.0</b>
3.50	12.0	3.50	32	<b>3331-3.5</b>
4.00	12.0	4.00	40	<b>3331-4.0</b>
4.50	14.0	4.50	50	<b>3331-4.5</b>
5.00	14.0	5.00	50	<b>3331-5.0</b>
6.00	16.0	6.00	50	<b>3331-6.0</b>

# MICRO-Line

Fraises en bout de finition

Schlicht Schafffräser

Finishing end mills

3341 / 3361

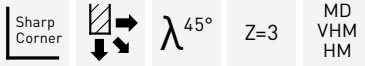
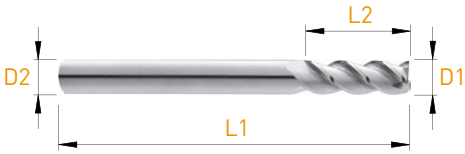

D1 e9	L2	D2 h6	L1	Art. N°
2.00	8.0	2.00	32	<b>3341-2.0</b>
2.50	8.0	2.50	32	<b>3341-2.5</b>
3.00	12.0	3.00	32	<b>3341-3.0</b>
3.50	12.0	3.50	32	<b>3341-3.5</b>
4.00	12.0	4.00	40	<b>3341-4.0</b>
4.50	14.0	4.50	50	<b>3341-4.5</b>
5.00	14.0	5.00	50	<b>3341-5.0</b>
6.00	16.0	6.00	50	<b>3341-6.0</b>



D1 e9	L2	D2 h6	L1	Art. N°
2.00	8.0	2.00	32	<b>3361-2.0</b>
2.50	8.0	2.50	32	<b>3361-2.5</b>
3.00	12.0	3.00	32	<b>3361-3.0</b>
3.50	12.0	3.50	32	<b>3361-3.5</b>
4.00	12.0	4.00	40	<b>3361-4.0</b>
4.50	14.0	4.50	50	<b>3361-4.5</b>
5.00	14.0	5.00	50	<b>3361-5.0</b>
6.00	16.0	6.00	50	<b>3361-6.0</b>

Fraises en bout de finition

Schlicht Schafffräser

Finishing end mills

3431 / 3441

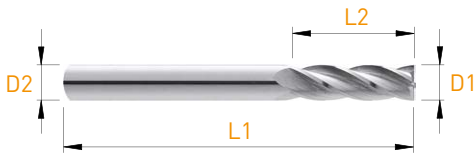

D1 e <sub>9</sub>	L2	D2 h <sub>6</sub>	L1	Art. N°
2.00	8.0	2.00	32	<b>3431-2.0</b>
2.50	8.0	2.50	32	<b>3431-2.5</b>
3.00	12.0	3.00	32	<b>3431-3.0</b>
3.50	12.0	3.50	32	<b>3431-3.5</b>
4.00	12.0	4.00	40	<b>3431-4.0</b>
4.50	14.0	4.50	50	<b>3431-4.5</b>
5.00	14.0	5.00	50	<b>3431-5.0</b>
6.00	16.0	6.00	50	<b>3431-6.0</b>

D1 e <sub>9</sub>	L2	D2 h <sub>6</sub>	L1	Art. N°
2.00	8.0	2.00	32	<b>3441-2.0</b>
2.50	8.0	2.50	32	<b>3441-2.5</b>
3.00	12.0	3.00	32	<b>3441-3.0</b>
3.50	12.0	3.50	32	<b>3441-3.5</b>
4.00	12.0	4.00	40	<b>3441-4.0</b>
4.50	14.0	4.50	50	<b>3441-4.5</b>
5.00	14.0	5.00	50	<b>3441-5.0</b>
6.00	16.0	6.00	50	<b>3441-6.0</b>

# MICRO-Line

Fraises en bout hémisphérique

Kugelschaftfräser

Ball nose end mills

3238 / 3338

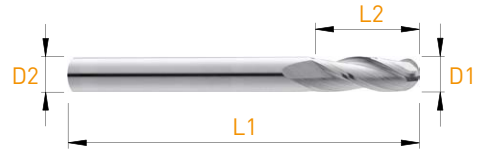
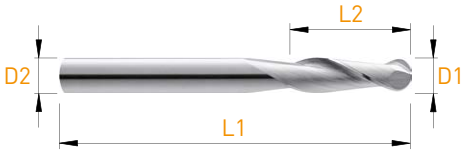

D1 e9	L2	D2 h6	L1	Art. N°
2.00	8.0	2.00	32	<b>3238-2.0</b>
2.50	8.0	2.50	32	<b>3238-2.5</b>
3.00	12.0	3.00	32	<b>3238-3.0</b>
3.50	12.0	3.50	32	<b>3238-3.5</b>
4.00	12.0	4.00	40	<b>3238-4.0</b>
4.50	14.0	4.50	50	<b>3238-4.5</b>
5.00	14.0	5.00	50	<b>3238-5.0</b>
6.00	16.0	6.00	50	<b>3238-6.0</b>

D1 e9	L2	D2 h6	L1	Art. N°
2.00	8.0	2.00	32	<b>3338-2.0</b>
2.50	8.0	2.50	32	<b>3338-2.5</b>
3.00	12.0	3.00	32	<b>3338-3.0</b>
3.50	12.0	3.50	32	<b>3338-3.5</b>
4.00	12.0	4.00	40	<b>3338-4.0</b>
4.50	14.0	4.50	50	<b>3338-4.5</b>
5.00	14.0	5.00	50	<b>3338-5.0</b>
6.00	16.0	6.00	50	<b>3338-6.0</b>

Fraises en bout pour usinage en bout plat

Schaftfräser für flache Frontbearbeitung

End mills for flat front machining

3383

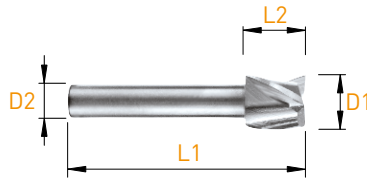

D1 h10	L2	D2 h6	L1	Art. N°
8.00	8.0	6.00	40	3383-8.0
10.00	10.0	6.00	40	3383-10.0
12.00	12.0	6.00	40	3383-12.0

Fraises en bout avec queue réduite

Schaftfräser mit reduziertem Schaft

End mills with reduced shank

3830

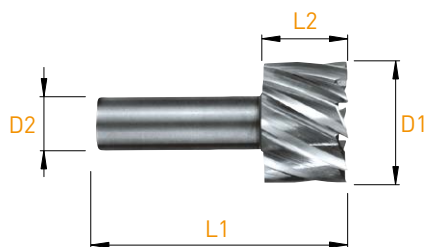

D1 h10	L2	D2 h6	L1	Art. N°
16.3	15.0	10.00	45	3831
20.3	15.0	10.00	45	3833

# MICRO-Line

Fraises à angler  
Kegelsenker  
Chamfering tools

3911



Z=3

MD  
VHM  
HM

D1	L2	D2 h <sub>6</sub>	L1	d	Art. N°
0.50	3.0	3.00	39	0.1	3911-0.5
1.00	3.0	3.00	39	0.1	3911-1.0
1.50	4.5	3.00	39	0.1	3911-1.5
2.00	6.0	3.00	39	0.1	3911-2.0
2.50	7.5	3.00	39	0.1	3911-2.5
3.00	-	3.00	39	0.1	3911-3.0

Fraises à angler  
Kegelsenker  
Chamfering tools

1901 / 3901

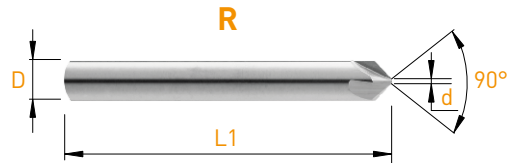

Z=4

MD  
VHM  
HM

L

R

D h <sub>6</sub>	d	L1	Art. N°	Art. N°
3.00	0.3	39	1901-3.0	3901-3.0
6.00	0.7	50	1901-6.0	3901-6.0
8.00	1.2	58	1901-8.0	3901-8.0

## APPLITEC SWISS TOOLING

OUTILS DE HAUTES PERFORMANCES  
POUR LE DÉCOLLETAGE  
ET LA MICROMÉCANIQUE

HOCHLEISTUNGSWERKZEUGE  
FÜR DREHAUTOMATEN  
UND MIKROMECHANIK

HIGH PERFORMANCE TOOLING  
FOR AUTOMATIC LATHES  
AND MICROMECHANICS



[WWW.APPLITEC-TOOLS.COM](http://WWW.APPLITEC-TOOLS.COM)

APPLITEC





Définition du nombre de dents  
Empfohlene Zähnezahl  
Recommended number of teeth > **9.02**

Conseils d'utilisation  
Anwendungsempfehlungen  
Application recommendations > **9.03**

Fraises circulaires en métal dur – denture fine  
VHM-Kreissägeblätter – feine Verzahnung  
Solid carbide slitting saws – fine teeth

**Type 1101**

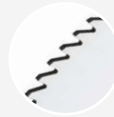

> **9.04**

Fraises circulaires en métal dur – denture grossière  
VHM-Kreissägeblätter – grobe Verzahnung  
Solid carbide slitting saws – large teeth

**Type 1102**



> **9.06**

Fraises circulaires en métal dur – denture extra-fine  
VHM-Kreissägeblätter – extra feine Verzahnung  
Solid carbide slitting saws – extra fine teeth

**Type 1103**



> **9.08**

Exécutions spéciales  
Sonderanfertigungen  
Special executions



> **9.10**

Disques en métal dur rectifiés  
Fertig geschliffene VHM-Ronden  
Fully ground solid carbide discs

**Type 1106**



> **9.12**

Tasseaux porte-fraise avec serrage avant  
Fräsdorne mit Spannung von vorne  
Milling arbors with front clamping

**Type 2810 / 2811 / 2815**



> **9.16**

Tasseaux porte-fraise avec serrage arrière  
Fräsdorne mit Spannung von hinten  
Milling arbors with rear clamping

**Type 2820 / 1820**



> **9.17**

# CIRCO-Line

Définition du nombre de dents

Empfohlene Zähnezahl

Recommended number of teeth

Idéalement 2-3 dents en contact

Im Idealfall 2-3 Zähne im Einsatz

Ideally 2-3 teeth in contact

**Trop de dents** = avance trop faible par dent / pas assez de place pour le copeau

**Trop peu de dents** = risque de vibration / usure prématurée

**Zu viele Zähne** = zu geringer Vorschub pro Zahn / zu kleiner Spanraum

**Zu wenig Zähne** = Vibrationen / Verschleissrisiko

**Too many teeth** = feed too low per tooth / not enough place for the chips

**Not enough teeth** = vibration / risk of quick wearout

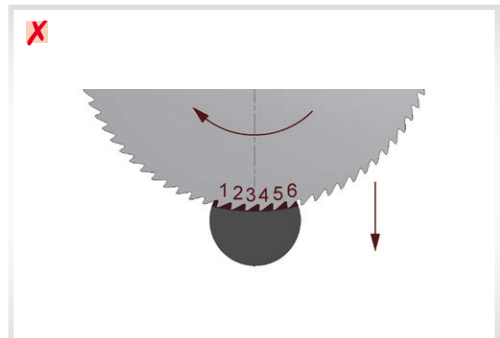
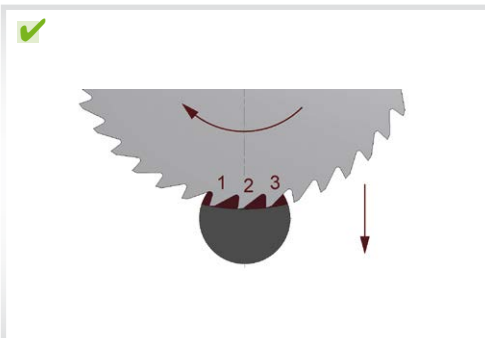
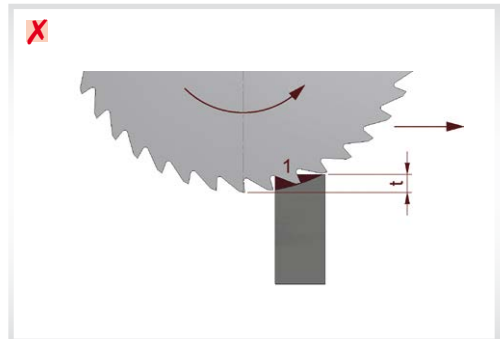
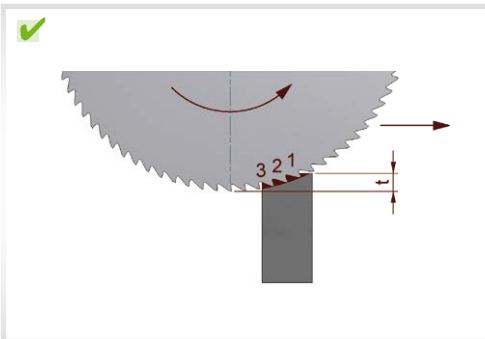
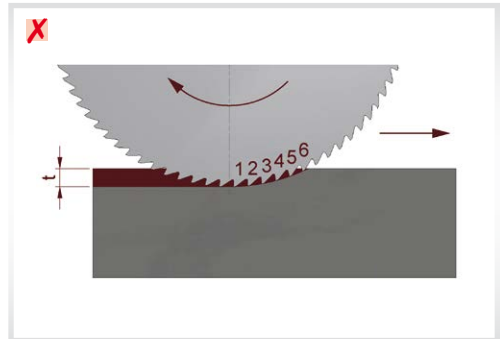
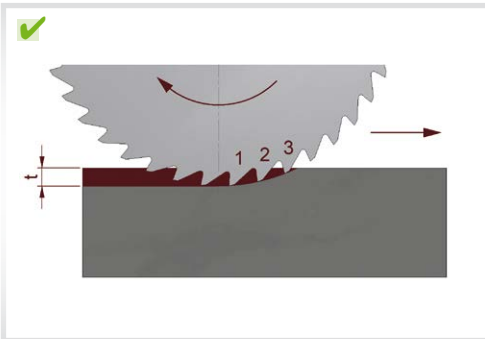

## Conseils d'utilisation

## Anwendungsempfehlungen

## Application recommendations

			Fraises circulaires en métal dur VHM-Kreissägeblätter Solid carbide slitting saws	
Matière Werkstoff Material	Lubrifiant* Kühlung* Coolant*	VC (m/min)	Choix de la denture / avance Verzahnungswahl / Vorschub Teeth selection / cutting feed	
Acier de décolletage Automatenstahl Free-cutting steel	O / E	120 - 240	<p><b>Type 1101</b></p> <ul style="list-style-type: none"> <li>• Pour usinage peu profond ou longueur à fendre faible. Avance par dent: 0.005-0.05**</li> <li>• Für geringe Bearbeitungstiefen oder kurze Schlitzlängen. Vorschub pro Zahn: 0.005-0.05**</li> <li>• For low machining depth or short slots. Feed per tooth: 0.005-0.05**</li> </ul> <p><b>Type 1102</b></p> <ul style="list-style-type: none"> <li>• Pour usinage profond ou grande longueur à fendre. Avance par dent: 0.01-0.1**</li> <li>• Für grosse Bearbeitungstiefen oder grosse Schlitzlängen. Vorschub pro Zahn: 0.01-0.1**</li> <li>• For deep machining or long slots. Feed per tooth: 0.01-0.1**</li> </ul> <p><b>Type 1103</b></p> <ul style="list-style-type: none"> <li>• Pour usinage de pièces fragiles ou fines. Avance par dent: 0.002-0.02**</li> <li>• Für die Bearbeitung von empfindlichen oder dünnwandigen Werkstücken. Vorschub pro Zahn: 0.002-0.02**</li> <li>• For machining of fragile or thin workpieces. Feed per tooth: 0.002-0.02**</li> </ul> <p>** selon la matière, l'épaisseur ainsi que la rigidité globale ** je nach Werkstoff, Dicke und Gesamtstarrheit ** according to material, thickness and global rigidity</p>	
Acier Stahl Steel < 600 N/mm <sup>2</sup>	O / E	100 - 200		
Acier Stahl Steel < 800 N/mm <sup>2</sup>	O / E	80 - 160		
Acier Stahl Steel < 1000 N/mm <sup>2</sup>	O / E	60 - 120		
Acier Stahl Steel > 1000 N/mm <sup>2</sup>	O / E	40 - 80		
Acier inoxydable Rostfreistahl Stainless steel	O / E	50 - 100		
Acier réfractaire Warmfester Stahl Heat resistant steel	O / E	25 - 60		
Fonte Gusseisen Cast iron	A / E	60 - 120		
Aluminium Si < 12%	O / E	150 - 600		
Aluminium Si > 12%	O / E	80 - 300		
Titane Titan Titanium	O / E	30 - 60		
Cuivre, laiton, bronze Kupfer, Messing, Bronze Copper, brass, bronze	A / O / E	80 - 300		
Thermoplastique Thermoplaste Thermoplastics	A	200 - 700		
Duroplastique Duroplaste Duroplastics	A	150 - 600		

\* O = huile de coupe / Schneidöl / cutting oil

\* E = Emulsion

\* A = sec (air comprimé) / Trocken (Pressluft) / dry (air)

avec revêtement TiN / TiCN / TiAlN, augmenter les valeurs de 20%

mit TiN / TiCN / TiAlN Beschichtung, Daten um 20% erhöhen

with TiN / TiCN / TiAlN coating, increase data by 20%

Denture fine  
Feine Verzahnung  
Fine teeth

DIN 1837

- Pour usinage peu profond ou longueur à fendre faible
- Für geringe Bearbeitungstiefen oder kurze Schlitzlängen
- For low machining depth or short slots
- Avance par dent: 0.005 - 0.05 mm
- Vorschub pro Zahn: 0.005 - 0.05 mm
- Feed per tooth: 0.005 - 0.05 mm
- Revêtement sur demande
- Beschichtung auf Anfrage
- Coating on request



Fraises circulaires en métal dur

VHM-Kreissägeblätter

Solid carbide slitting saws

## Type 1101

Denture fine Feine Verzahnung Fine teeth												DIN 1837
D1 js12 D2 H7	15 5	20 5	25 8	30 8	40 10	50 13	63 16	80 22	100 22	125 22	160 32	D1 js12 D2 H7
Epaisseur Dicke Thickness ±0.01	Nombre de dents Zähnezahl Number of teeth										Epaisseur Dicke Thickness ±0.01	
0.10	64	80	80	100	128							0.10
0.15	64	80	80	100	128							0.15
0.20	64	80	80	100	128	128	160					0.20
0.25	64	64	80	100	100	128	128					0.25
0.30	64	64	80	80	100	128	128	160				0.30
0.35	64	64	64	80	100	100	128	160				0.35
0.40	64	64	64	80	100	100	128	160				0.40
0.45	48	48	64	80	80	100	128	128				0.45
0.50	48	48	64	80	80	100	128	128	160			0.50
0.60	48	48	64	64	80	100	100	128	160	160		0.60
0.70	48	48	48	64	80	80	100	128	128	160		0.70
0.80	40	40	48	64	80	80	100	128	128	160		0.80
0.90	40	40	48	64	64	80	100	100	128	160		0.90
1.00	40	40	48	64	64	80	100	100	128	160	160	1.00
1.10	40	40	48	48	64	80	80	100	128	128		1.10
1.20	40	40	48	48	64	80	80	100	128	128	160	1.20
1.30	40	40	40	48	64	64	80	100	100			1.30
1.40	40	40	40	48	64	64	80	100	100	128		1.40
1.50	40	40	40	48	64	64	80	100	100	128	160	1.50
1.60	40	40	40	48	64	64	80	100	100	128	160	1.60
1.70	40	32	40	48	48	64	80	80	100			1.70
1.80	40	32	40	48	48	64	80	80	100	128	128	1.80
1.90	40	32	40	48	48	64	80	80	100			1.90
2.00	40	32	40	48	48	64	80	80	100	128	128	2.00
2.50	40	32	40	40	48	64	64	80	100	100	128	2.50
3.00	40	32	32	40	48	48	64	80	80	100	128	3.00
3.50	24	24	32	40	40	48	64	64	80	100		3.50
4.00	24	24	32	40	40	48	64	64	80	100		4.00
5.00	24	24	32	32	40	48	48	64	80	100		5.00
6.00	24	24	24	32	40	40	48	64	64	100		6.00

Denture grossière  
Grobe Verzahnung  
Large teeth

DIN 1838

- Pour usinage profond ou grande longueur à fendre
- Für grosse Bearbeitungstiefen oder grosse Schlitzlängen
- For deep machining pr long slots
- Avance par dent: 0.01 - 0.1 mm
- Vorschub pro Zahn: 0.01 - 0.1 mm
- Feed per tooth: 0.01 - 0.1 mm
- Revêtement sur demande
- Beschichtung auf Anfrage
- Coating on request



Fraises circulaires en métal dur

VHM-Kreissägeblätter

Solid carbide slitting saws

## Type 1102

Denture grossière Grobe Verzahnung Large teeth												DIN 1838
D1 js12 D2 H7	15 5	20 5	25 8	30 8	40 10	50 13	63 16	80 22	100 22	125 22	160 32	D1 js12 D2 H7
Epaisseur Dicke Thickness ±0.01	Nombre de dents Zähnezahl Number of teeth										Epaisseur Dicke Thickness ±0.01	
0.20	20	20	20	30	40							0.20
0.25	20	20	20	30	40							0.25
0.30	20	20	20	30	40							0.30
0.40	20	20	20	30	40	48	64					0.40
0.50	20	20	20	30	40	48	64					0.50
0.60	20	20	20	30	40	48	48	64	80			0.60
0.70	20	20	20	30	40	40	48	64	64			0.70
0.80	20	20	20	24	32	40	48	64	64	80		0.80
0.90	20	20	20	24	32	40	48	48	64	80		0.90
1.00	20	20	20	24	32	40	48	48	64	80	80	1.00
1.20	20	20	20	24	32	40	40	48	64	64	80	1.20
1.50	20	20	20	24	32	32	40	48	48	64	80	1.50
1.60	20	20	20	24	32	32	40	48	48	64		1.60
1.80	20	20	20	24	24	32	40	40	48	64		1.80
2.00	20	20	20	24	24	32	40	40	48	64	80	2.00
2.50	20	20	20	24	24	32	32	40	48	48	80	2.50
3.00	20	20	20	24	24	24	32	40	40	48	64	3.00
4.00	20	20	20	24	20	24	32	32	40	48		4.00
5.00	20	20	20	24	20	24	24	32	40	40		5.00
6.00	20	20	20	24	20	20	24	32	32	40		6.00

Denture extra-fine  
Extra feine Verzahnung  
Extra fine teeth

- Pour usinage de pièces fragiles ou fines
- Avance par dent: 0.002 - 0.03 mm
- Idéal pour le décolletage
- Revêtement sur demande
- Für die Bearbeitung von empfindlichen oder dünnwandigen Werkstücken
- Vorschub pro Zahn: 0.002 - 0.03 mm
- Für Langdrehautomaten besonders empfehlenswert
- Beschichtung auf Anfrage
- For machining of fragile or thin workpieces
- Feed per tooth: 0.002 - 0.03 mm
- Recommended on automatic lathes
- Coating on request





Fraises circulaires en métal dur

VHM-Kreissägeblätter

Solid carbide slitting saws

## Type 1103

Denture extra-fine Extra feine Verzahnung Extra fine teeth													
D1 js12 D2 H7	8 3	10 3	12 5	15 5	20 5	20 5	20 6	25 5	25 6	25 8	30 8	32 8	D1 js12 D2 H7
Epaisseur Dicke Thickness ±0.01	Nombre de dents Zähnezahl Number of teeth											Epaisseur Dicke Thickness ±0.01	
0.10	48	64	64	80	*	100	80	80					0.10
0.15	48	64	64	80	*	100	80	80	100	100	*	80	0.15
0.20	48	64	64	80	*	100	80	80	100	100	*	80	0.20
0.25	48	64	64	80	80	100	80	80	100	100	*	80	0.25
0.30	48	64	64	80	80	100	80	80	100	100	100	80	0.30
0.35	48	64	64	80	80		80	80	100	100	100	80	0.35
0.40	48	64	64	80	80	100	80	80	100	100	100	80	0.40
0.50	48	64	64	80	80	100	80	80	100	100	100	80	0.50
0.60	48	64	64	80	80		80	80	100	100	100	80	0.60
0.70	48	64	64	80	80		80	80	100	100	100	80	0.70
0.80	48	64	64	80	80		80	80	100	100	100	80	0.80
0.90	48	64	64	80	80		80	80	100	100	100	80	0.90
1.00	48	64	64	80	80		80	80	100	100	100	80	1.00
1.20				80	80		80	80	100	100	100	80	1.20
1.50				80	80		80	80	100	100	100	80	1.50
2.00				80	80		80	80	100	100	100	80	2.00
2.50				80	80		80	80	100	100	100	80	2.50
3.00				80	80		80	80	100	100	100	80	3.00

D1 js12 D2 H7	35 8	40 8	40 8	40 10	40 10	45 8	45 8	50 10	50 13	63 16	80 16	D1 js12 D2 H7
0.10												0.10
0.15	96	100	160	100	160	100	160					0.15
0.20	96	100	160	100	160	100	160	100				0.20
0.25	96	100	160	*	160	100	160	100	120	120		0.25
0.30	96	100	160	*	160	100	160	100	120	120		0.30
0.35	96	100	160	*	160	100	160	100	120	120		0.35
0.40	96	100	160	*	160	100	160	100	120	120		0.40
0.50	96	100	160	100	160	100	160	100	120	120	128	0.50
0.60	96	100	160	100	160	100	160	100	120	120	128	0.60
0.70	96	100	160	100	160	100	160	100	120	120	128	0.70
0.80	96	100	160	100	160	100	160	100	120	120	128	0.80
0.90	96	100	160	100	160	100	160	100	120	120	128	0.90
1.00	96	100	160	100	160	100	160	100	120	120	128	1.00
1.20	96	100	160	100	160	100	160	100	120	120	128	1.20
1.50	96	100	160	100	160	100	160	100	120	120	128	1.50
2.00	96	100	160	100	160	100	160	100	120	120	128	2.00
2.50	96	100	160	100	160	100	160	100	120	120	128	2.50
3.00	96	100	160	100	160	100	160	100	120	120	128	3.00

\* voir type 1101 / siehe Typ 1101 / see type 1101

- *Denture forme B*
  - *Denture forme W*
  - *Train de fraises*
  - *Alésage avec entrée de clavette*
  - *Autres exécutions spéciales sur demande*
  - *Revêtement sur demande*
- *B Zahnform*
  - *W Zahnform*
  - *Spezielle Kreissägeblätter im Satz*
  - *Bohrung mit Keilnute*
  - *Andere Sonderanfertigungen auf Anfrage*
  - *Beschichtung auf Anfrage*



## Special executions

- *Tooth form B*
- *Tooth form W*
- *Special slitting saws in set*
- *Bore with keyway*
- *Other special executions on request*
- *Coating on request*



Prêt pour le taillage de la denture  
Bereit zum Verzahnen  
Ready for teeth grinding

- Finition poli miroir des deux faces avec dépouille
- Alésage tolérance H7
- Diamètre surdimensionné ~0.15 mm
- Hochglanz Seiten mit Hohlschliff
- H7 Bohrung Toleranz
- Aussendurchmesser mit ~0.15 mm Übermass
- Mirror finish on both sides with clearance
- Bore with H7 tolerance
- Outside diameter with ~0.15 mm oversize



Disques en métal dur rectifiés

Fertig geschliffene VHM-Ronden

Fully ground solid carbide discs

Ø 8-35 mm – Type 1106

Prêt pour le taillage de la denture Bereit zum Verzahnen Ready for teeth grinding													
D1 ~ +0.15 D2 H7	8	10	12	15	20	20	25	25	25	30	32	35	D1 ~ +0.15 D2 H7
Epaisseur Dicke Thickness ±0.01	Epaisseurs et alésages spéciaux sur demande Andere Dicken und Bohrungen auf Anfrage Other thicknesses and bores on request												Epaisseur Dicke Thickness ±0.01
0.10	■	■	■	■	■	■	■	■	■	■			0.10
0.15	■	■	■	■	■	■	■	■	■	■	■	■	0.15
0.20	■	■	■	■	■	■	■	■	■	■	■	■	0.20
0.25	■	■	■	■	■	■	■	■	■	■	■	■	0.25
0.30	■	■	■	■	■	■	■	■	■	■	■	■	0.30
0.35	■	■	■	■	■	■	■	■	■	■	■	■	0.35
0.40	■	■	■	■	■	■	■	■	■	■	■	■	0.40
0.45	□	□	□	■	■	■	■	□	■	■	□	■	0.45
0.50	■	■	■	■	■	■	■	■	■	■	■	■	0.50
0.60	■	■	■	■	■	■	■	■	■	■	■	■	0.60
0.70	■	■	■	■	■	■	■	■	■	■	■	■	0.70
0.80	■	■	■	■	■	■	■	■	■	■	■	■	0.80
0.90	■	■	■	■	■	■	■	■	■	■	■	■	0.90
1.00	■	■	■	■	■	■	■	■	■	■	■	■	1.00
1.10			□	■	■	□	□	□	■	■	□	□	1.10
1.20			□	■	■	■	■	■	■	■	■	■	1.20
1.30			□	■	■	□	□	□	■	■	□	□	1.30
1.40			□	■	■	□	□	□	■	■	□	□	1.40
1.50			■	■	■	■	■	■	■	■	■	■	1.50
1.60				■	■	□	□	□	■	■	□	□	1.60
1.70				■	■	□	□	□	■	■	□	□	1.70
1.80				■	■	□	□	□	■	■	□	□	1.80
1.90				■	■	□	□	□	■	■	□	□	1.90
2.00				■	■	■	■	■	■	■	■	■	2.00
2.50				■	■	■	■	■	■	■	■	■	2.50
3.00				■	■	■	■	■	■	■	■	■	3.00
3.50				■	■				■	■			3.50
4.00				■	■				■	■			4.00
5.00				■	■				■	■			5.00
6.00				■	■				■	■			6.00

Prêt pour le taillage de la denture  
Bereit zum Verzahnen  
Ready for teeth grinding

- Finition poli miroir des deux faces avec dépouille
- Alésage tolérance H7
- Diamètre surdimensionné  
~0.15 mm

- Hochglanz Seiten mit Hohlschliff
- H7 Bohrung Toleranz
- Aussendurchmesser mit  
~0.15 mm Übermass

- Mirror finish on both sides with clearance
- Bore with H7 tolerance
- Outside diameter with  
~0.15 mm oversize

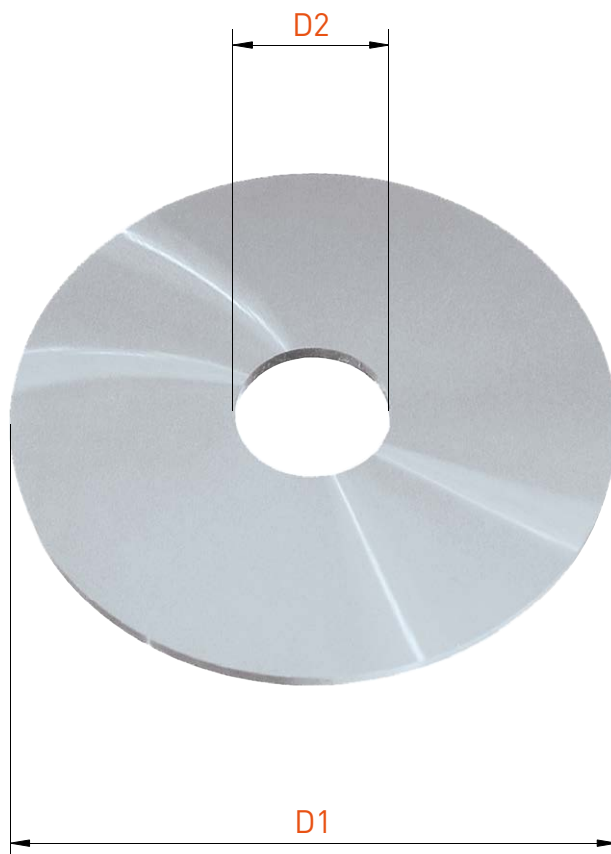

Disques en métal dur rectifiés

Fertig geschliffene VHM-Ronden

Fully ground solid carbide discs

Ø 40-160 mm – Type 1106

Prêt pour le taillage de la denture Bereit zum Verzahnen Ready for teeth grinding													
D1 ~ +0.15 D2 H7	40	40	45	50	50	63	80	80	100	125	160	160	D1 ~ +0.15 D2 H7
8	10	8	10	13	16	16	22	22	22	22	32		
Epaisseur Dicke Thickness ±0.01	Epaisseurs et alésages spéciaux sur demande Andere Dicken und Bohrungen auf Anfrage Other thicknesses and bores on request												Epaisseur Dicke Thickness ±0.01
0.10		■											0.10
0.15	■	■	■										0.15
0.20	■	■	■	■	■	■							0.20
0.25	■	■	■	■	■	■		□					0.25
0.30	■	■	■	■	■	■		■					0.30
0.35	■	■	■	■	■	■		■					0.35
0.40	■	■	■	■	■	■		■					0.40
0.45	■	■	□	□	■	■		■					0.45
0.50	■	■	■	■	■	■	■	■	■				0.50
0.60	■	■	■	■	■	■	■	■	■	■			0.60
0.70	■	■	■	■	■	■	■	■	■	■			0.70
0.80	■	■	■	■	■	■	■	■	■	■			0.80
0.90	■	■	■	■	■	■	■	■	■	■			0.90
1.00	■	■	■	■	■	■	■	■	■	■	□	■	1.00
1.10	□	■	□	□	■	■	□	■	■	■	□	□	1.10
1.20	■	■	■	■	■	■	■	■	■	■	□	■	1.20
1.30	■	■	□	□	■	■	□	■	■	■	□	□	1.30
1.40	■	■	□	□	■	■	□	■	■	■	□	□	1.40
1.50	■	■	■	■	■	■	■	■	■	■	□	■	1.50
1.60	□	■	□	□	■	■	□	■	■	■		■	1.60
1.70	□	■	□	□	■	■	□	■	■	□		□	1.70
1.80	□	■	□	□	■	■	□	■	■	■		■	1.80
1.90	□	■	□	□	■	■	□	■	■	□		□	1.90
2.00	■	■	■	■	■	■	■	■	■	■		■	2.00
2.50	■	■	■	■	■	■	■	■	■	■		■	2.50
3.00	■	■	■	■	■	■	■	■	■	■		■	3.00
3.50		■			■	■		■	■	■			3.50
4.00		■			■	■		■	■	■			4.00
5.00		■			■	■		■	■	■			5.00
6.00		■			■	■		■	■	■			6.00

Tasseaux porte-fraise avec serrage avant

Fräsdorne mit Spannung von vorne

Milling arbors with front clamping

## Type 2810 / 2811 / 2815

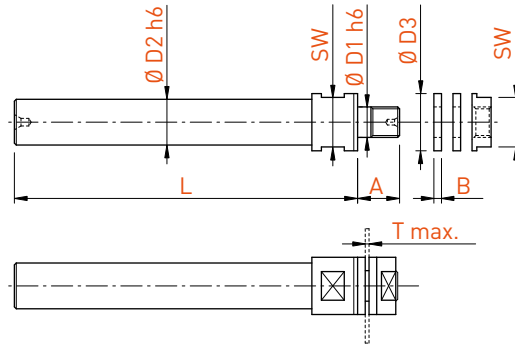

Type 2810	Rotation à droite (filet à droite) Drehrichtung rechts (Rechtsgewinde) Right hand rotation (right hand thread)							Art. N°
	D1 h6	D2 h6	D3	L	A	B	SW	
5.0	6.0	10.0	70	9.0	2.0	8.0	6.0	2810-5-6
5.0	10.0	10.0	80	9.0	2.0	8.0	6.0	2810-5-10
6.0	10.0	12.0	80	9.5	2.0	10.0	6.0	2810-6-10
8.0	10.0	15.0	80	10.0	2.0	13.0	6.0	2810-8-10
8.0	12.0	15.0	90	10.0	2.0	13.0	6.0	2810-8-12
10.0	6.0	18.0	80	10.5	2.0	15.0	6.0	2810-10-6
10.0	10.0	18.0	80	10.5	2.0	15.0	6.0	2810-10-10
10.0	16.0	18.0	100	10.5	2.0	15.0	6.0	2810-10-16
13.0	16.0	22.0	110	11.0	2.0	19.0	6.0	2810-13-16
16.0	20.0	26.0	120	12.0	2.0	22.0	6.0	2810-16-20
22.0	16.0	32.0	132	13.0	2.0	27.0	6.0	2810-22-16

Type 2811	Rotation à droite (filet à droite) Drehrichtung rechts (Rechtsgewinde) Right hand rotation (right hand thread)							Art. N°
	D1 h6	D2 h6	D3	L	A	B	SW	
16.0	10.0	22.0	80	8.0	2.0	19.0	3.0	2811-16-10

Type 2815	Pour petites fraises circulaires (filet à droite) Für kleine Kreissägeblätter (Rechtsgewinde) For small slitting saws (right hand thread)							Art. N°
	D1 h6	D2 h6	D3	L	A	B	SW	
3.0	5.0	5.0	60	7.0	1.0	4.0	3.0	2815-3-5
5.0	6.0	7.5	70	7.0	1.0	6.0	3.0	2815-5-6



Tasseaux porte-fraise avec serrage arrière

Fräsdorne mit Spannung von hinten

Milling arbors with rear clamping

## Type 2820 / 1820

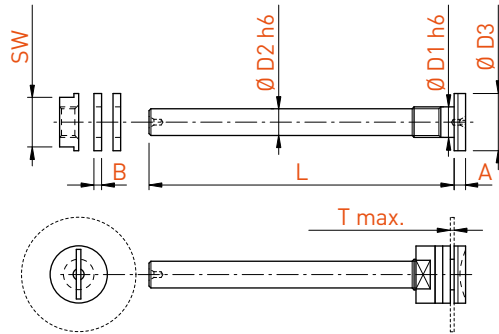

Type 2820	Rotation à droite (filet à gauche) Drehrichtung rechts (Linksgewinde) Right hand rotation (left hand thread)							
D1 h6	D2 h6	D3	L	A	B	SW	T max.	Art. N°
5.0	4.0	10.0	50	3.0	2.0	8.0	6.0	2820-5-4
6.0	5.0	12.0	60	3.0	2.0	10.0	6.0	2820-6-5
8.0	6.0	15.0	70	3.0	2.0	13.0	6.0	2820-8-6
8.0	7.0	15.0	80	3.0	2.0	13.0	6.0	2820-8-7
10.0	6.0	18.0	70	3.5	2.0	15.0	6.0	2820-10-6
10.0	8.0	18.0	90	3.5	2.0	15.0	6.0	2820-10-8
13.0	10.0	22.0	110	3.5	2.0	19.0	6.0	2820-13-10
16.0	12.0	26.0	120	3.5	2.0	22.0	6.0	2820-16-12

Type 1820	Rotation à gauche (filet à droite) Drehrichtung links (Rechtsgewinde) Left hand rotation (right hand thread)							
D1 h6	D2 h6	D3	L	A	B	SW	T max.	Art. N°
5.0	4.0	10.0	50	3.0	2.0	8.0	6.0	1820-5-4
6.0	5.0	12.0	60	3.0	2.0	10.0	6.0	1820-6-5
8.0	6.0	15.0	70	3.0	2.0	13.0	6.0	1820-8-6
10.0	6.0	18.0	70	3.5	2.0	15.0	6.0	1820-10-6

Chaque tasseau est livré avec 2 entretoises et 1 écrou

Jeder Fräsdorn wird mit 2 Abstandsringen und 1 Mutter geliefert

2 distance rings and 1 nut are included with each arbor

Pièces de rechange Ersatzteile Spare parts	Art. N°	Art. N°
	1820-D1*-A	1820-D1*-B
	2810-D1*-A	2810-D1*-B
	2811-D1*-A	2811-D1*-B
	2815-D1*-A	2815-D1*-B
	2820-D1*-A	2820-D1*-B

\* Diamètre D1 à spécifier \* Durchmesser D1 angeben \* Diameter D1 to be specified

# INDEX

## Répertoire des articles

## Artikelverzeichnis

## Index of items

Art. N°	Page	Art. N°	Page	Art. N°	Page			
10	1010	8.13	254	3.14	335	1.16		
11	1101	9.05	254X	3.15	336	1.16		
	1102	9.07	256	3.16	3361	8.32		
	1103	9.09	26	260	3.04	337	1.18	
	1106	9.13		260/250	3.07	3371-1.3	8.06	
	1107	7.19		260-C	3.05	3371-2	8.07	
12	1200	7.14		260-JET	3.06	3371-3	8.07	
14	1400	7.02		261	3.08	338	1.18 / 1.19	
	1401	7.03		261-E	3.18	3383	8.35	
	1402	7.18		261L	3.08	339	1.19	
	1420	7.04		261XF	3.09	34	340-JET	1.17
	1460	7.05		262	3.10		342	1.16
15	1500	7.15		2620	7.16		343	1.16
	1510	7.15		262S05	3.11		3431	8.33
16	1600	7.16		262X	3.10		344	1.16
	1610	7.17		263	3.12		3441	8.33
	1680-120°	8.12		2630	7.17		345	1.16
	1680-90°	8.11		263S05	3.11		346	1.16
18	1820	9.17		263VX	3.13		347	1.18
19	1901	8.36		263X	3.12		348	1.18 / 1.19
20	2010	8.13		264	3.14		349	1.19
	2011	8.14		264X	3.15	38	3830	8.35
	2012	8.14		266	3.16	39	3901	8.36
	2013	8.15		2680-120°	8.12		3911	8.36
	2014	8.15		2680-90°	8.11	70	7050	1.140
	2020	8.16	28	2810	9.16		7051	1.141
	2023	8.18		2820	9.17		7051-E	1.145
	2026	8.20	31	311	1.12 / 1.13		7051R	1.143
	2030	8.22		312	1.12 / 1.13		7060	1.140
22	2200	7.14		313	1.12 / 1.13		7061	1.141
24	2400	7.02		314	1.12 / 1.13		7061-E	1.145
	2401	7.03		315	1.12 / 1.13		7061L	1.143
	2402	7.18		316	1.12 / 1.13	71	710	1.22
	2405	7.08		317	1.14		710-NOVIBRA	1.23 / 1.162
	2420	7.04		3170	8.03		710-SF	1.163
	2425	7.09		318	1.14 - 1.15		711	1.24
	2435	7.12		319	1.15		711-EP	1.31
	2436	7.13	32	321	1.12 / 1.13		711-ESF	1.165
	2440-0	7.10		322	1.12 / 1.13		711SF	1.164
	2440-12	7.11		323	1.12 / 1.13		712	1.25
	2440-18	7.11		3231	8.31		712SF	1.164
	2440-26	7.11		3238	8.34		713	1.26
	2440-8	7.11		324	1.12 / 1.13		713SF	1.165
	2441	7.10		325	1.12 / 1.13		714	1.29
	2450	7.07		326	1.12 / 1.13		716	1.30
	2450-SP	7.06		327	1.14 / 1.15	72	720	1.22
	2460	7.07		3271-0.75	8.04		721	1.24
	2470	7.06		3271-1.5	8.04		721-EP	1.31
25	250	3.04		3271-3	8.05		722	1.25
	250-JET	3.06		3271-5	8.05		723	1.26
	250RC	3.05		3271-8	8.06		724	1.29
	251	3.08		3278-0.75	8.08		726	1.30
	251-E	3.17		3278-1.5	8.08	73	730	1.34 / 1.39
	251R	3.08		3278-3	8.09		730-DECO10	1.154
	251RXF	3.09		328	1.14 / 1.15		730-JET	1.38
	251XF	3.09		329	1.15		730-NOVIBRA	1.39 / 1.166
	252	3.10	33	332	1.16		730RC	1.36
	2520	7.15		333	1.16		730R-DECO10	1.152
	252S05	3.11		3330	8.30		730R-MULTISWISS	1.158
	252X	3.10		3331	8.31		731	1.40
	253	3.12		3336-HA	8.29		731-E	1.74
	2530	7.15		3337-HA	8.29		731R	1.47
	253S05	3.11		3338	8.34		731RSF	1.171
	253VX	3.13		334	1.16		732	1.54
	253X	3.12		3341	8.32		733	1.57

## Répertoire des articles

## Artikelverzeichnis

## Index of items

Art. N°	Page
734	1.64
735	1.69
736	1.70
737	1.73
<b>74</b> 740	1.34 / 1.35
740/730-D	1.37
740-DECO10	1.152
740-JET	1.38
740L-DECO10	1.154
740-NOVIBRA	1.39 / 1.166
740-SF	1.167
740Z	1.150
741	1.40
741-E	1.74
741-ESF	1.169
741L	1.47
741SF	1.168
742	1.54
742SF	1.168
743	1.57
743SF	1.169
744	1.64
745	1.69
746	1.70
747	1.73
748SF	1.170
749SF	1.170
<b>75</b> 750	1.78
750-JET	1.82
750RAS	1.159
750RC	1.79
750R-DECO10	1.153
750R-MULTISWISS	1.158
751	1.84
751-E	1.128
751R	1.93
752	1.104
753	1.108
754	1.118
756	1.123
757	1.126
<b>76</b> 760	1.78
760/750-25	1.78
760/750-D	1.81
760-JET	1.82
760LC	1.80
760L-DECO10	1.155
760-NOVIBRA	1.830
760Z	1.150
761	1.84
761-E	1.128
761L	1.93
762	1.104
763	1.108
764	1.118
766	1.123
767	1.126
<b>77</b> 770	1.130
770RC	1.131
770R-DECO-13	1.156
770R-DECO-20	1.157
771	1.132
771-E	1.138
771R	1.134
<b>78</b> 780	1.130

Art. N°	Page
781	1.132
781-E	1.138
781L	1.135
<b>C</b> C3-740	1.151
C4-760	1.151
CCGT-X17	4.15
CCGT-X25	4.16
CCGT-X8	4.14
CCMT-HF	4.17
CCMT-MF	4.17
CCMT-XF2	4.17
CUT16H	6.10
CUT16HX	6.11
CUT22H	6.10
CUT22-HD	6.12
CUT22HX	6.11
CUT22-JET	6.13
CUT31H	6.10
CUT31-HD	6.12
CUT31HX	6.11
CUT31-JET	6.13
CUT-GN	6.19
CUT-PN	6.16
CUT-PR	6.17
CUT-TN	6.18
CUT-UL	6.15
CUT-UN	6.14
<b>D</b> DCGT-X17	4.23
DCGT-X25	4.24
DCGT-X8	4.22
DCMT-HF	4.25
DCMT-MF	4.25
DCMT-XF2	4.25
<b>E</b> E300-P	8.26
E300-R	8.27
E900-P	8.27
<b>M</b> ML12A	6.28
ML12-AD1	6.41
ML12-AD2	6.41
ML12A-SWISS-NANO	6.23
ML12-CITIZEN	6.05
ML12-DECO10	6.18
ML12F	6.28
ML12-FIX	6.38
ML12-HANWHA	6.09
ML12-JET	6.38
ML12-MASTER	6.41
ML12-STAR	6.11
ML12-SWISS-NANO	6.22
ML16/20-AD1	6.41
ML16A	6.28
ML16-AD2	6.41
ML16-CITIZEN-L20	6.07
ML16-DECO13	6.19
ML16-DECO13-AD1	6.41
ML16-DECO13-AD2	6.41
ML16-DECO20	6.20
ML16F	6.28
ML16-FIX	6.38
ML16-HANWHA	6.08
ML16-JET	6.38
ML16-KMX26	6.10
ML16-MASTER	6.41
ML16-S20	6.21
ML16-STAR	6.11

Art. N°	Page
ML16-SWISS-ST26	6.26
ML20A	6.28
ML20-AD2	6.41
ML20-DELTA	6.25
ML20F	6.28
ML20-JET	6.38
ML20-MASTER	6.41
ML-JET	6.39
ML-PRESET-1	6.40
<b>S</b> SC..	4.12
SD..	4.18
SV..	4.26
<b>T</b> T216-EP	5.11
T216-FT	5.08
T216-GT	5.09
T216-GTX	5.10
T216-GX	5.07
T216-H	5.06
<b>V</b> VCGT-K18	4.31
VCGT-X10	4.30
VCGT-X17	4.33
VCGT-X25	4.34
VCGT-X8	4.32
VCGW-0	4.31
VCMT-HF	4.35
VCMT-MF	4.35
VCMT-XF2	4.35
<b>W</b> W750	1.146
W750-JET	1.147
W751	1.148
W760	1.146
W760-JET	1.147
W761	1.148

SWISS MADE

PERFORMANCE | PRECISION | RIGIDITY



**APPLITEC**  
SWISS TOOLING

REPRESENTED BY

**Applitec Moutier S.A.**  
Ch. Nicolas-Junker 2  
CH-2740 Moutier

Tél. +41 32 494 60 20  
Fax +41 32 493 42 60  
[www.applitec-tools.com](http://www.applitec-tools.com)